

Introduction to Computer Aided Engineering: Solidworks and Cosmosworks using CosmosXpress

**Tutorial written by Jerry Dutreuil
Professor Frank Fisher
Stevens Institute of Technology
Last updated : July 8, 2007**

**Software versions used in the tutorial :
- SolidWorks 2006 SP4.1**

Open SolidWorks

Step 1. Click on the New Tab on the top left corner of the screen

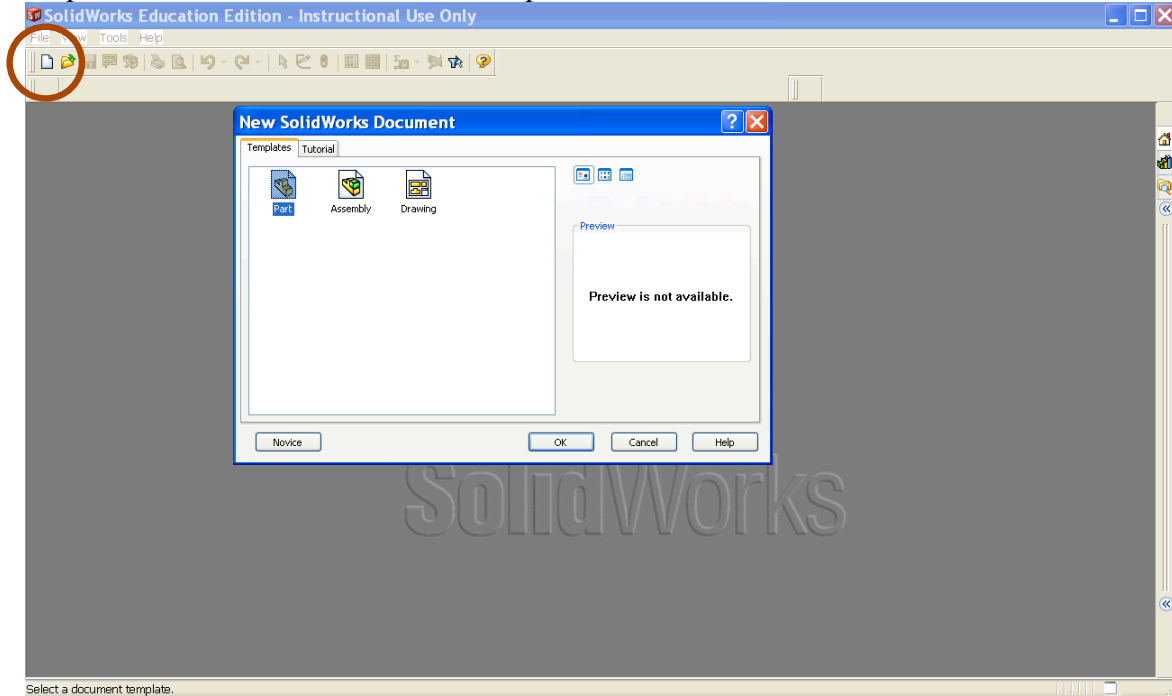

Click on Part and then ok

Step 2. Click on the Sketch command and then click on Sketch tab

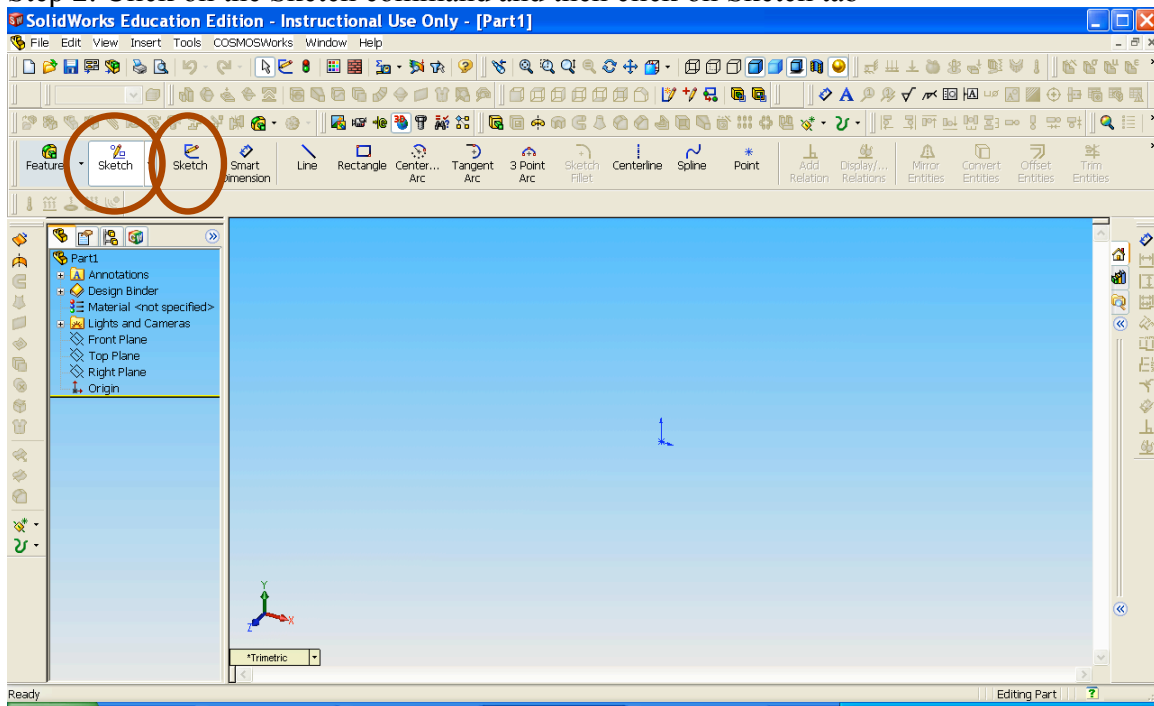

Select the Front Plane

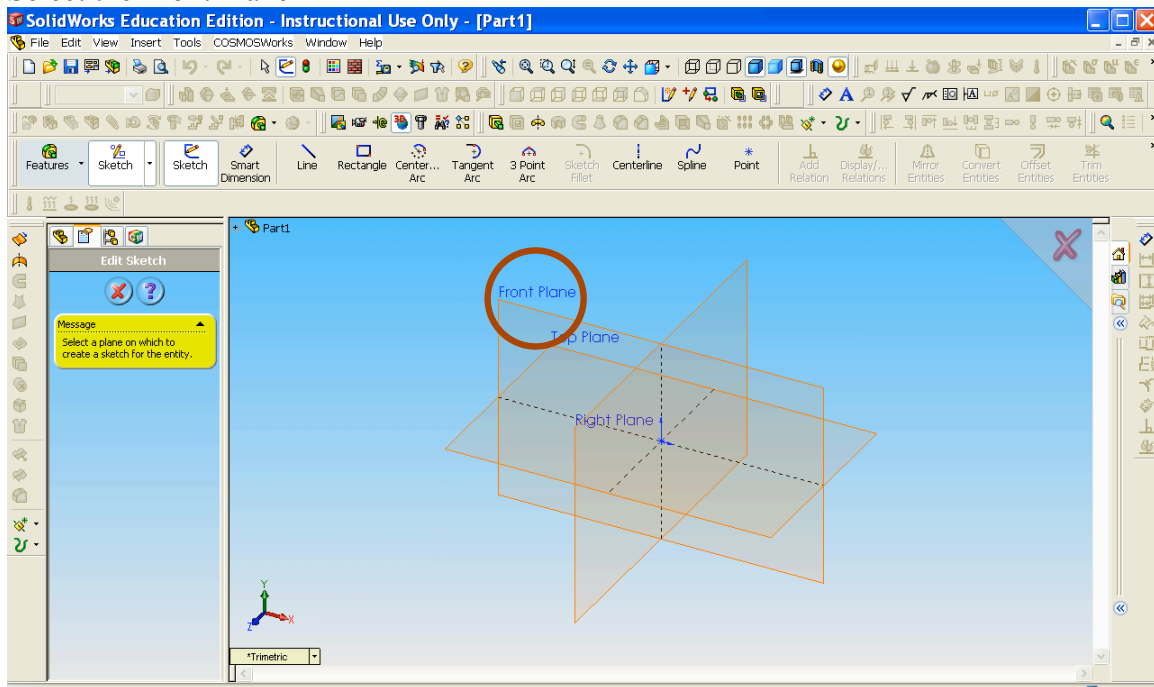

The screen will appear automatically.

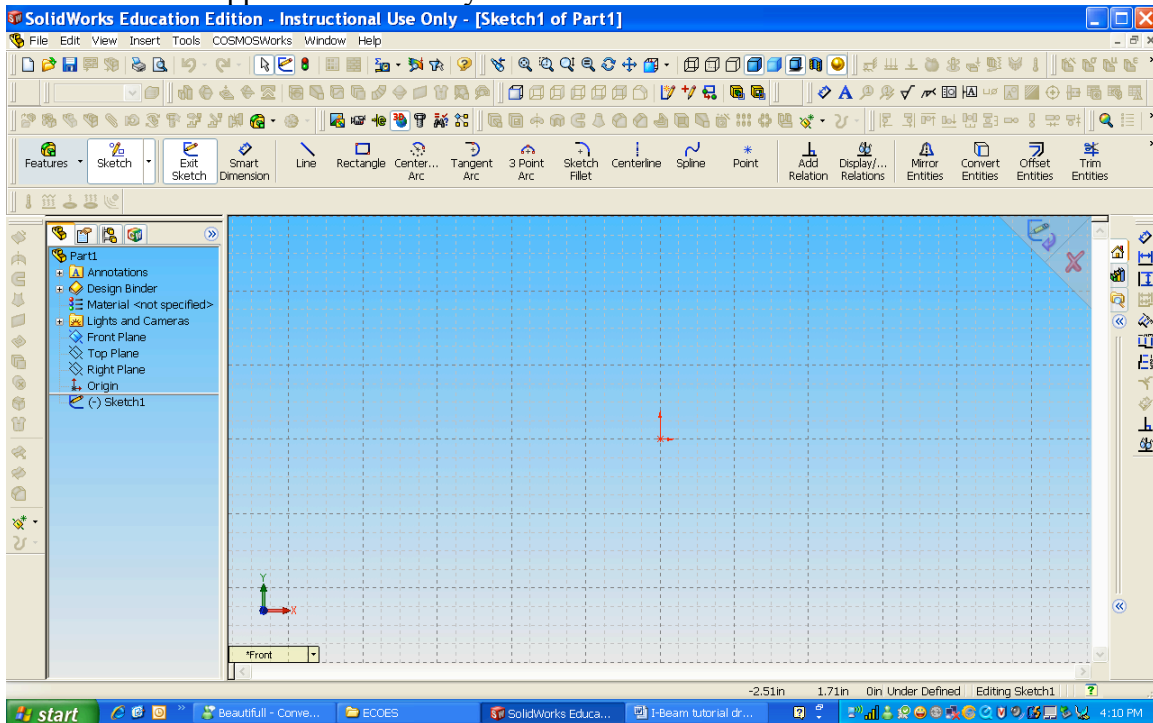

If the grid does not appear, go to tools, then options

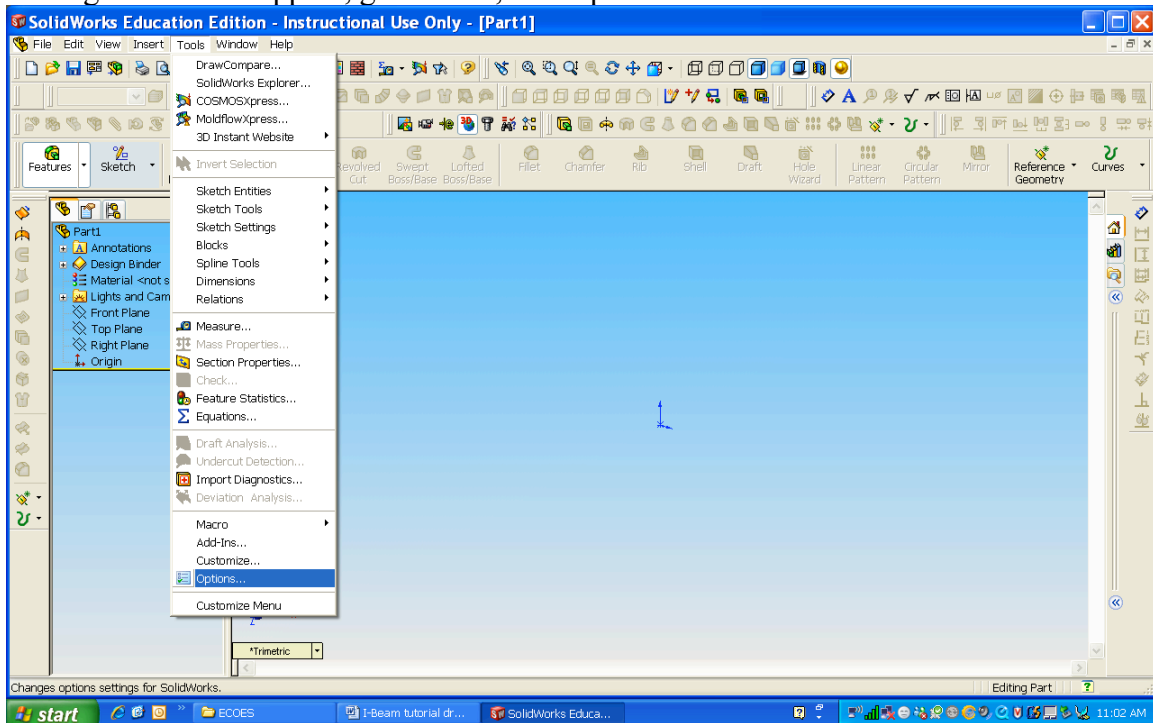

Click on the document properties tab.

On the left menu click on grids/snap, check “display grid” and click ok

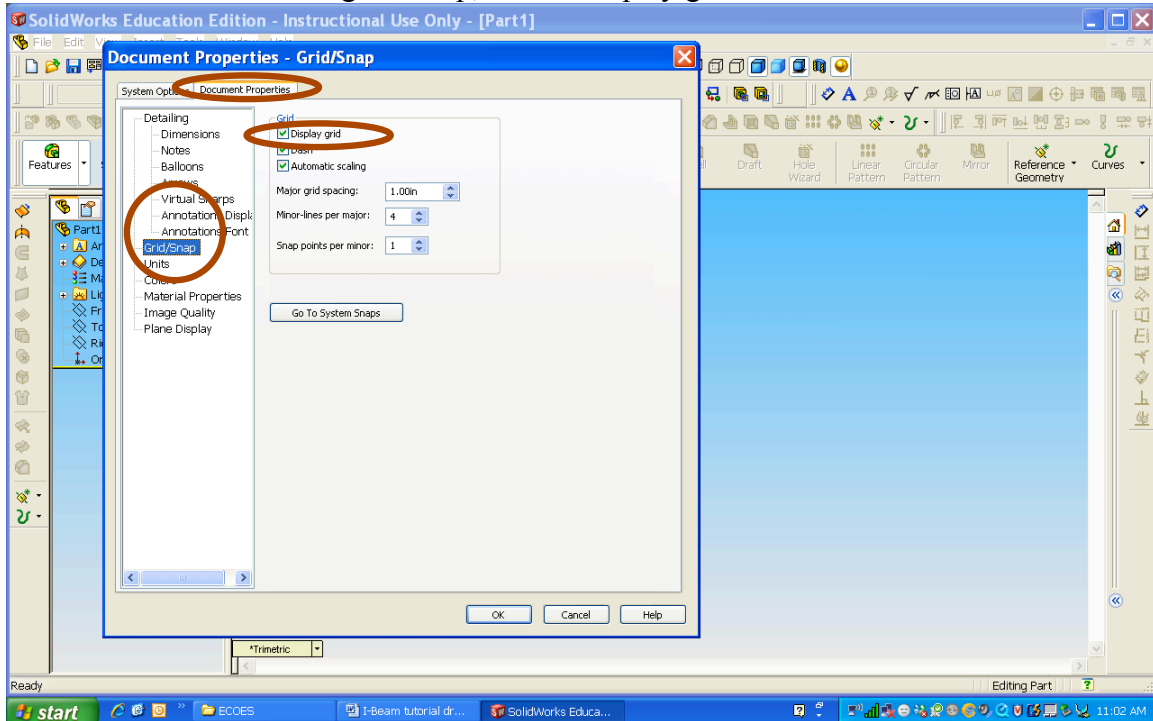

On the left menu again, below Grid/Snap click on units (this allows you to change the units to SI system). Then select MMGS (millimeter, gram, second) and click ok.

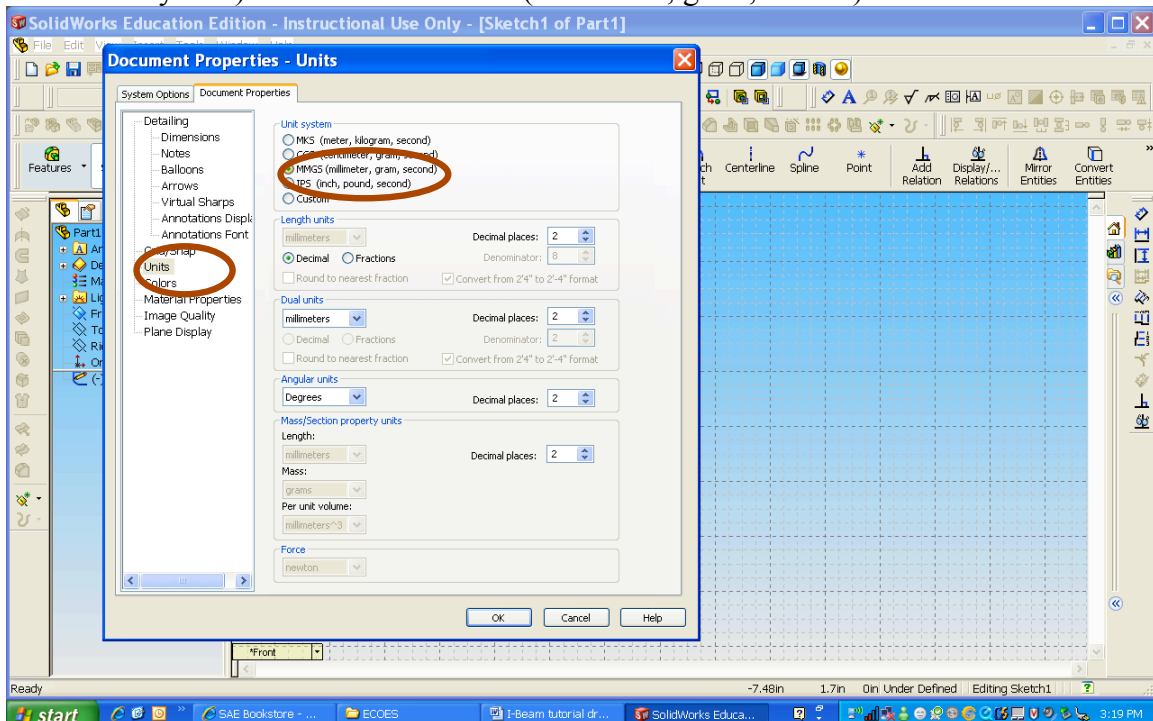

Complete the following sketch by clicking on line and starting at the origin which is in red. (Note that we will have a chance to define the lengths of the structure later, so don't worry about the exact lengths of the elements now.) But please make sure that the lines are horizontal and vertical

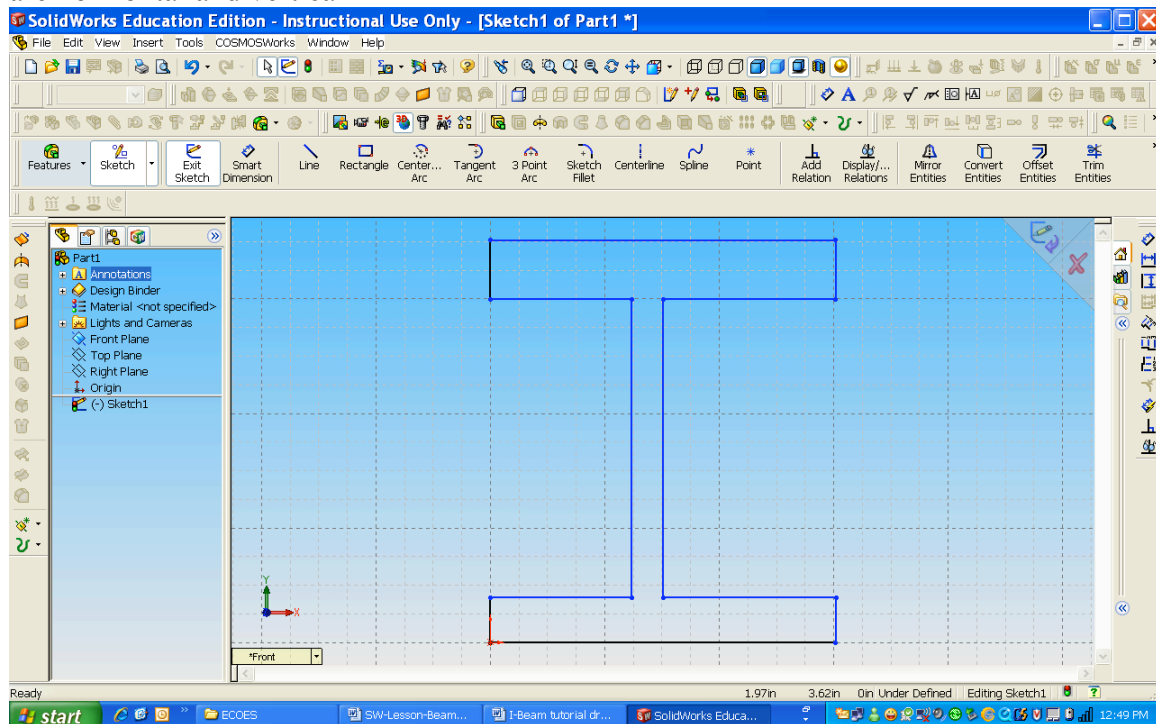

When you are done making the sketch, click on “line” again to remove the command
 Make sure that the line are horizontal and vertical by looking for the yellow square with the line inside.

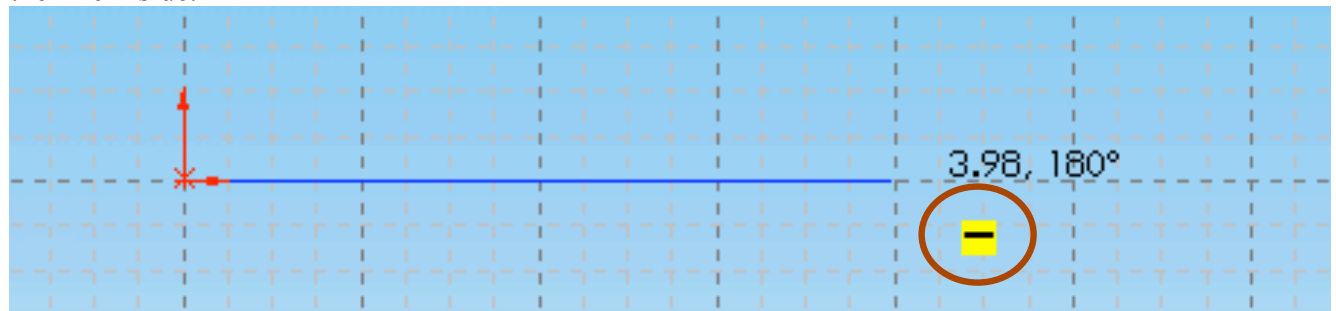

To make the beam symmetric, Click on ‘Add Relation’ and to your left you will see “Selected Entities”. Each time you pick one the four lines indicated below with the arrows, it will appear in the list. You can right click and clear your selection if you selected the wrong ling

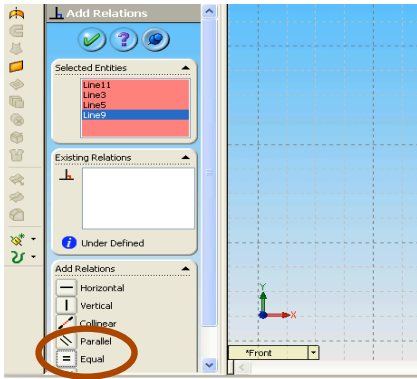

Then click on equal so that the selected lines are the same length. Click on the green check when you are done

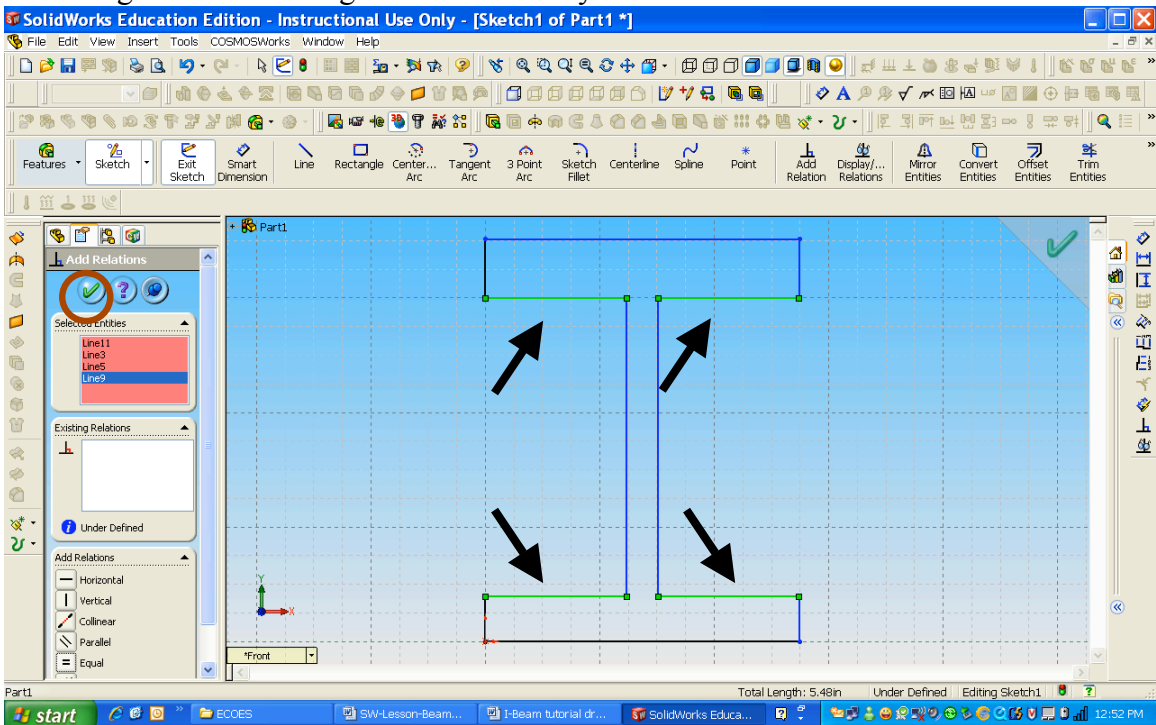

Repeat the same procedure for the sides and top and bottom lines



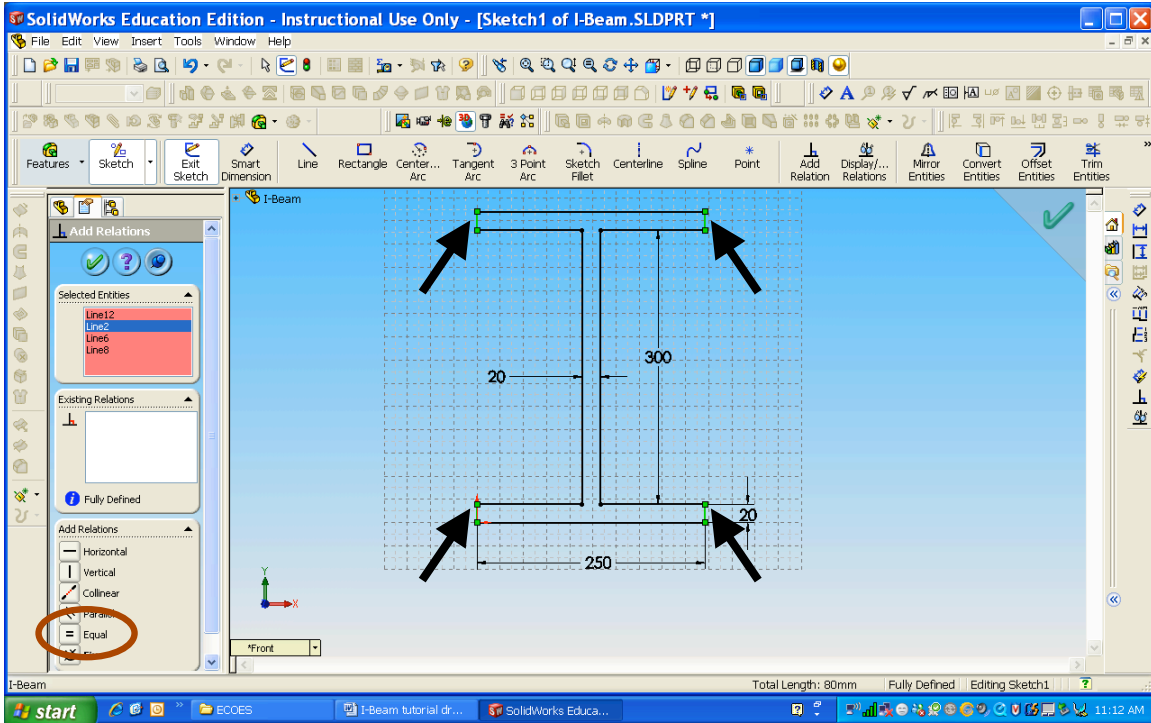

Then go to smart dimensions to add the dimensions of one of the equal length lines.
(Note that we'll be able to go back and change these dimensions later.)

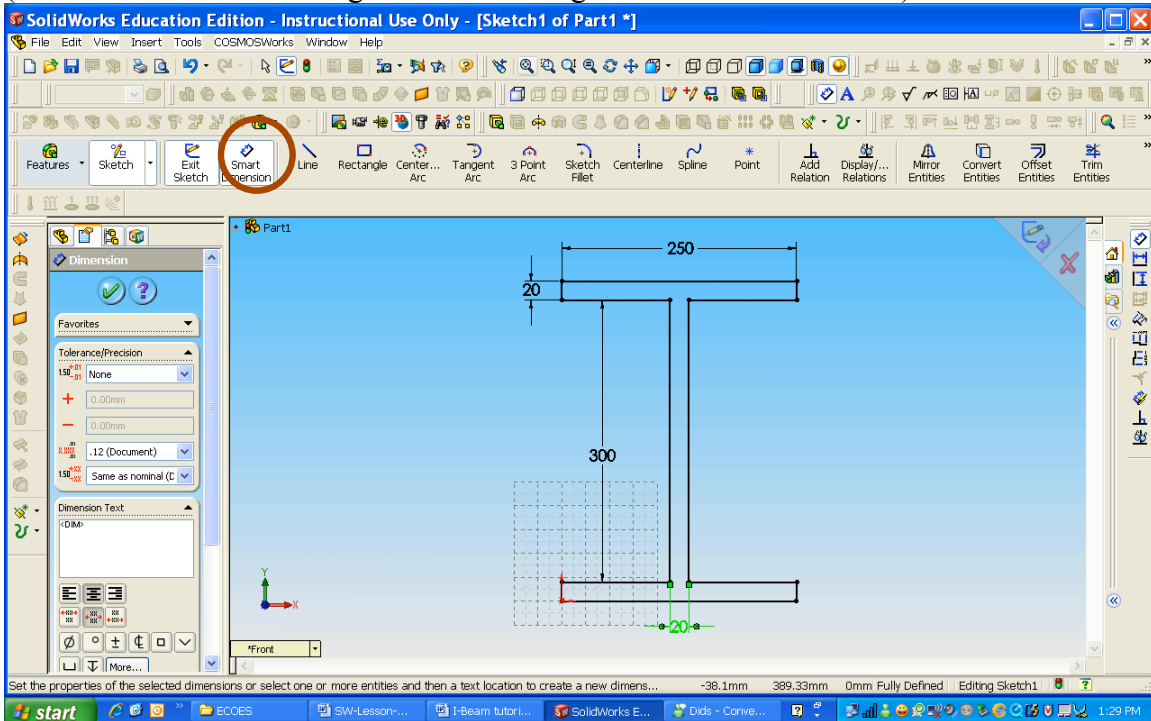

To view your sketch or solid shape in different angles, you can click on Standard Views and select the view that you want. Or you can hold the center buttons on the mouse and move your mouse to rotate your sketch or solid.

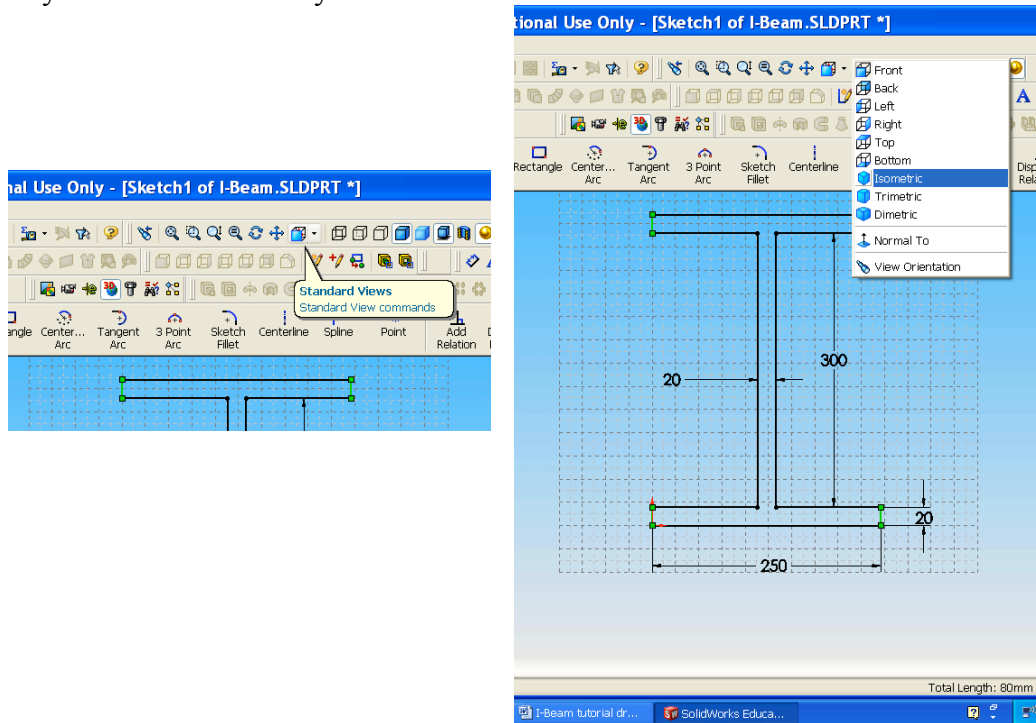

Go to Features and click on Extruded Boss/Base. When the feature manager appears, enter 6000 mm in the D1 box. Click on the green check when you are done.

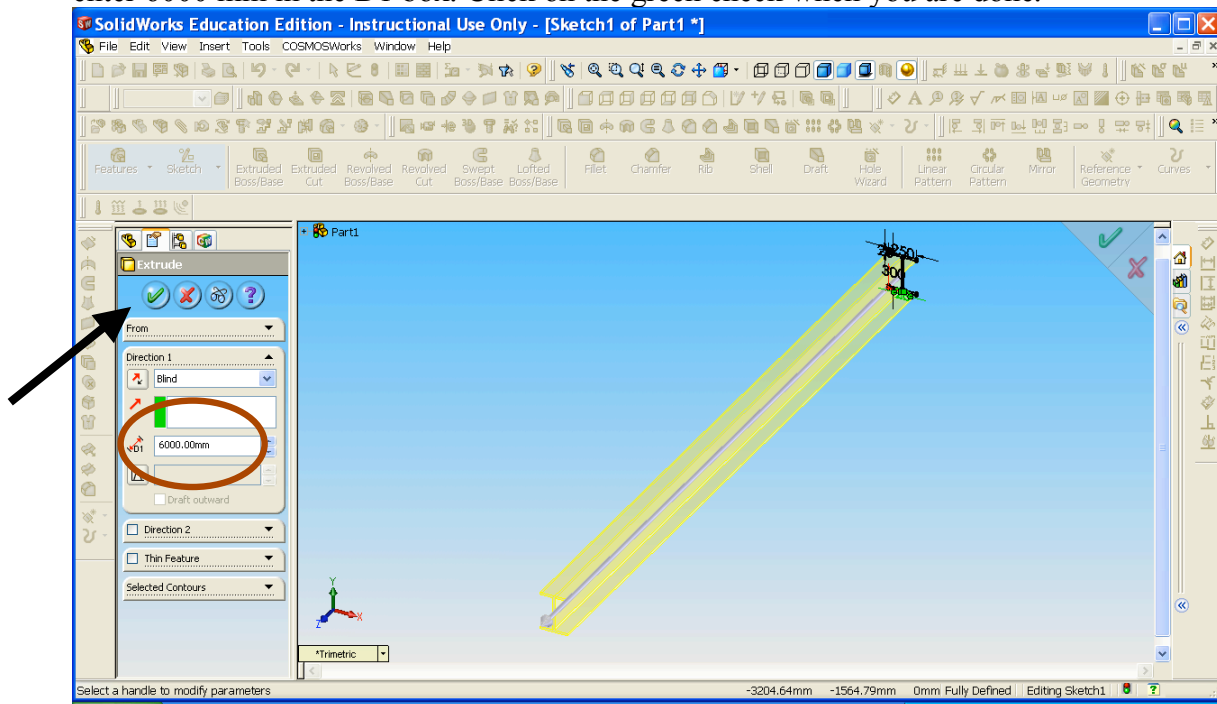

Click ok and you will have a solid I-Beam.

Go to tools, add-ins and remove Cosmos Works from the checked list.
Again go to tools and click on Cosmos Express

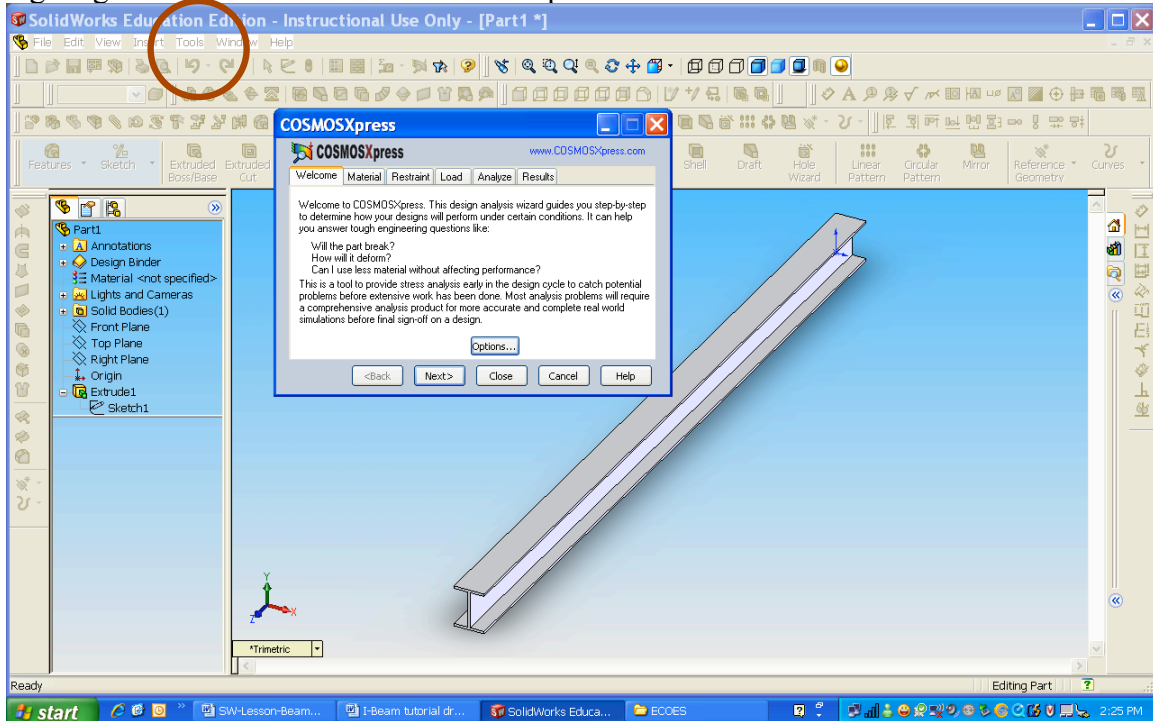

Click on Option to change the units to SI. Then click 'next>'

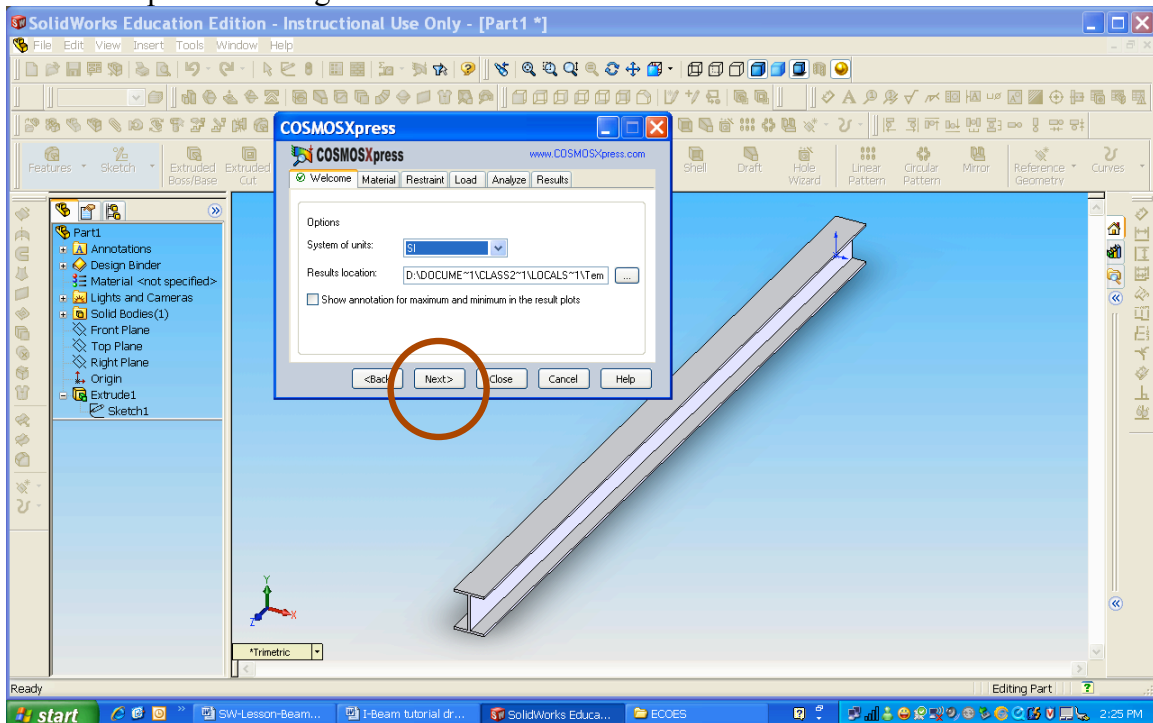

Click on Alloy Steel and apply to choose the material, and then click 'next'. (You may want to come back here and see how the material selection alters your results at the end of the tutorial.)

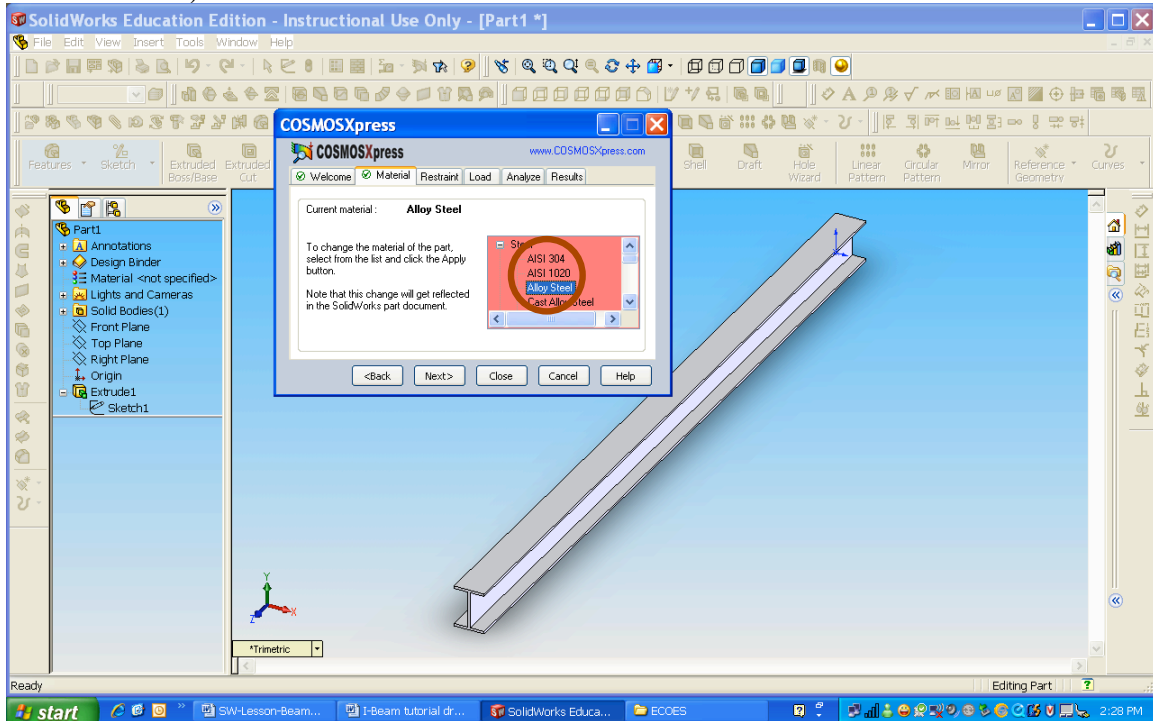

Double click 'next' to go to restraint.

Click on the I-shaped face to restrain the face from moving. You will see it appear in green in the pink box.

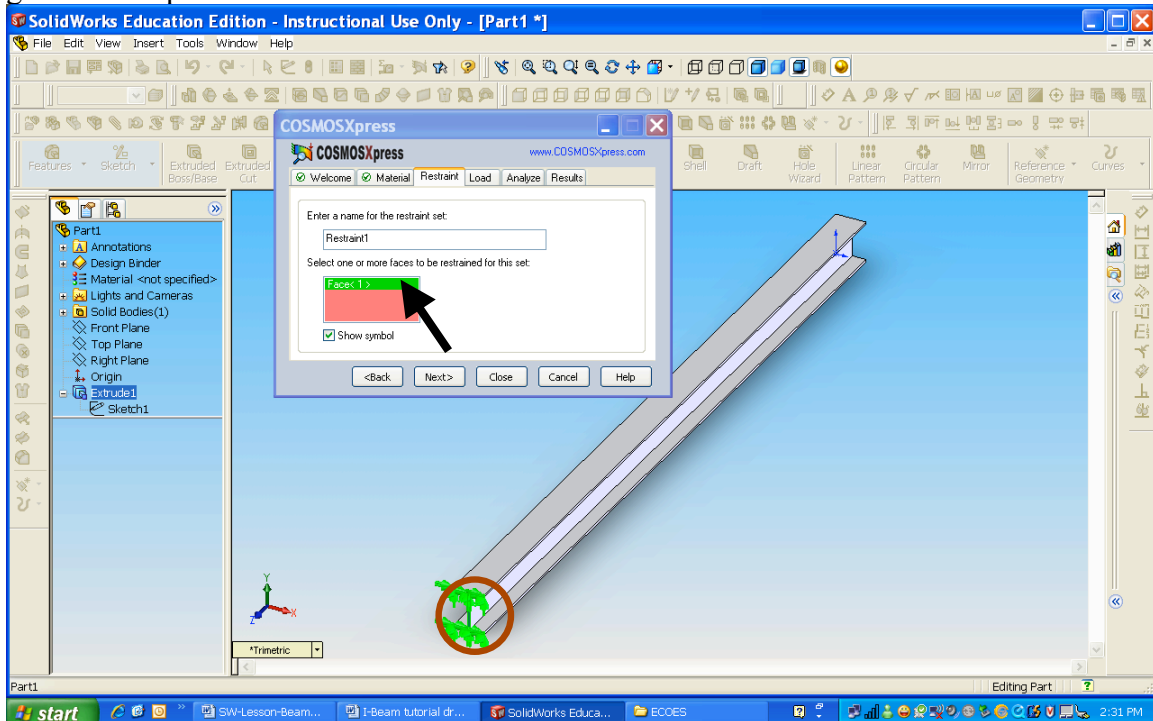

Double click on next and click on force

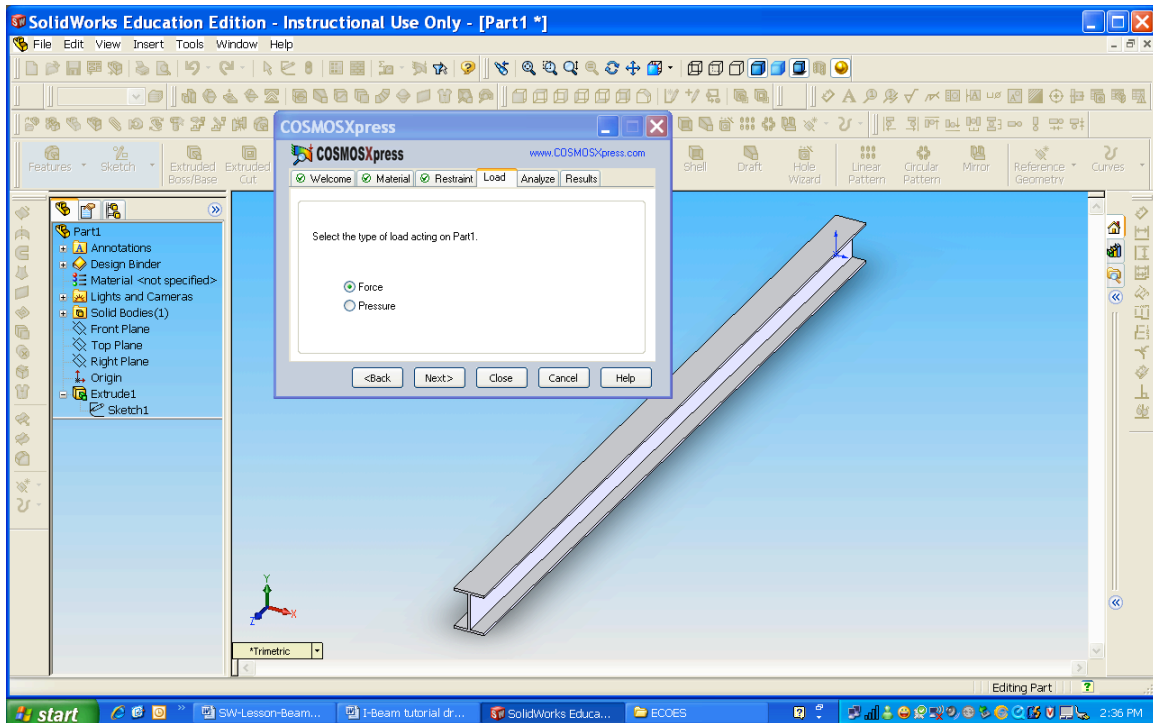

Click next and select the top face to apply the force on the beam. You will see the chosen face appear in the pink box and on the solid. (notice the face changing to a green color)

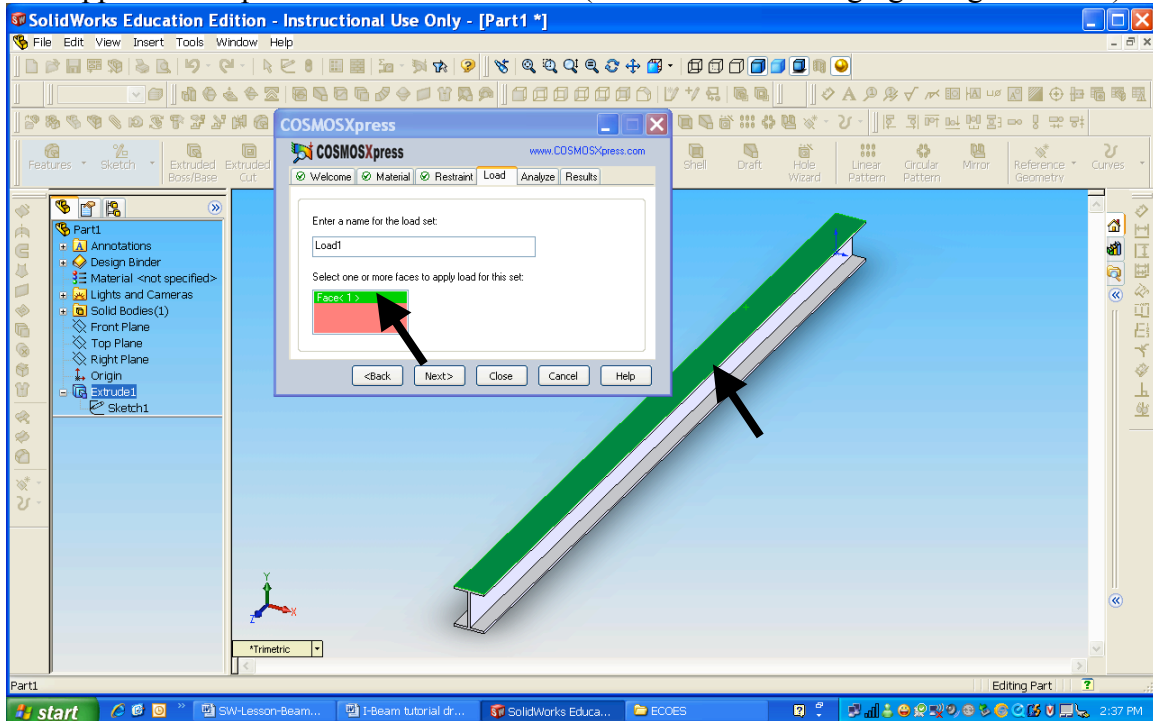

Click next and add the value of 30000N to the beam. Since the Load is applied normal to the face and over the whole surface of the beam, it is a distributed load.

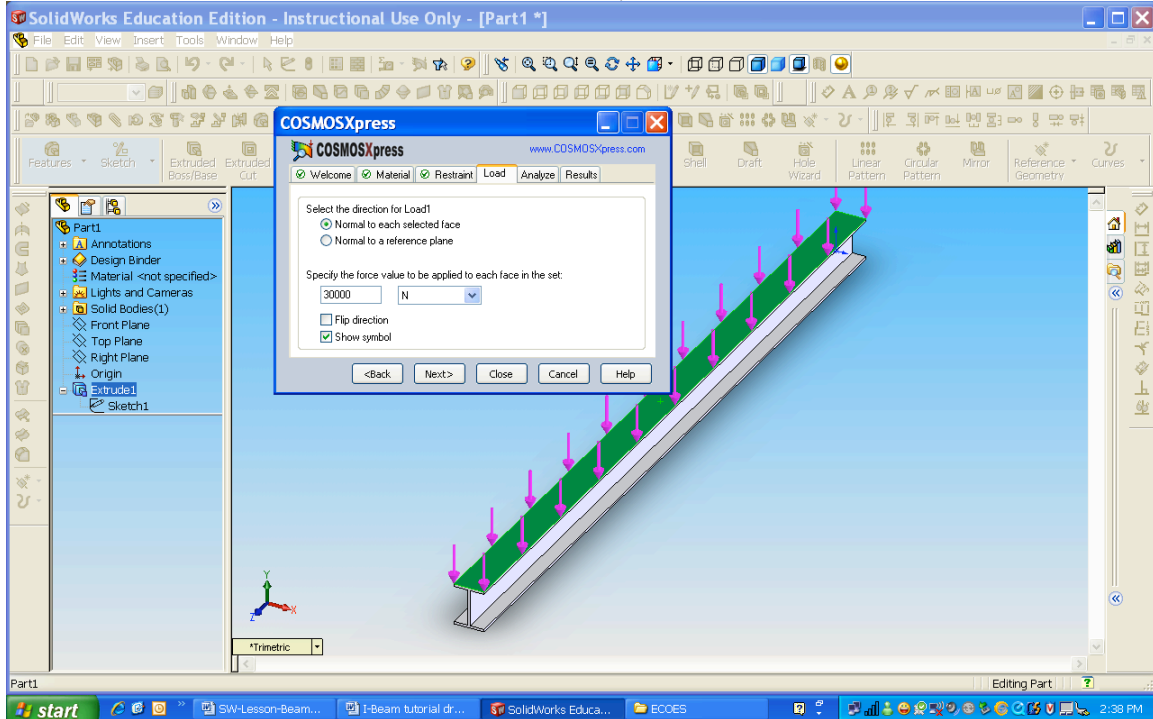

Click on 'Next' and choose Yes (recommended)

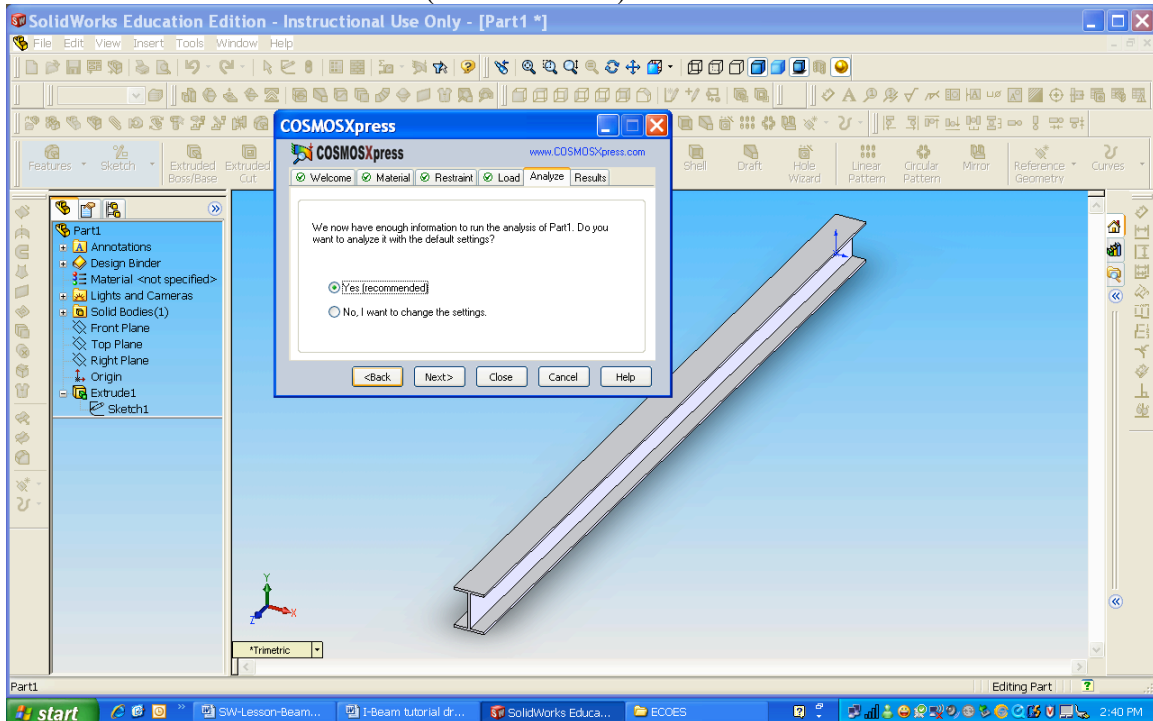

Click next and run the simulation

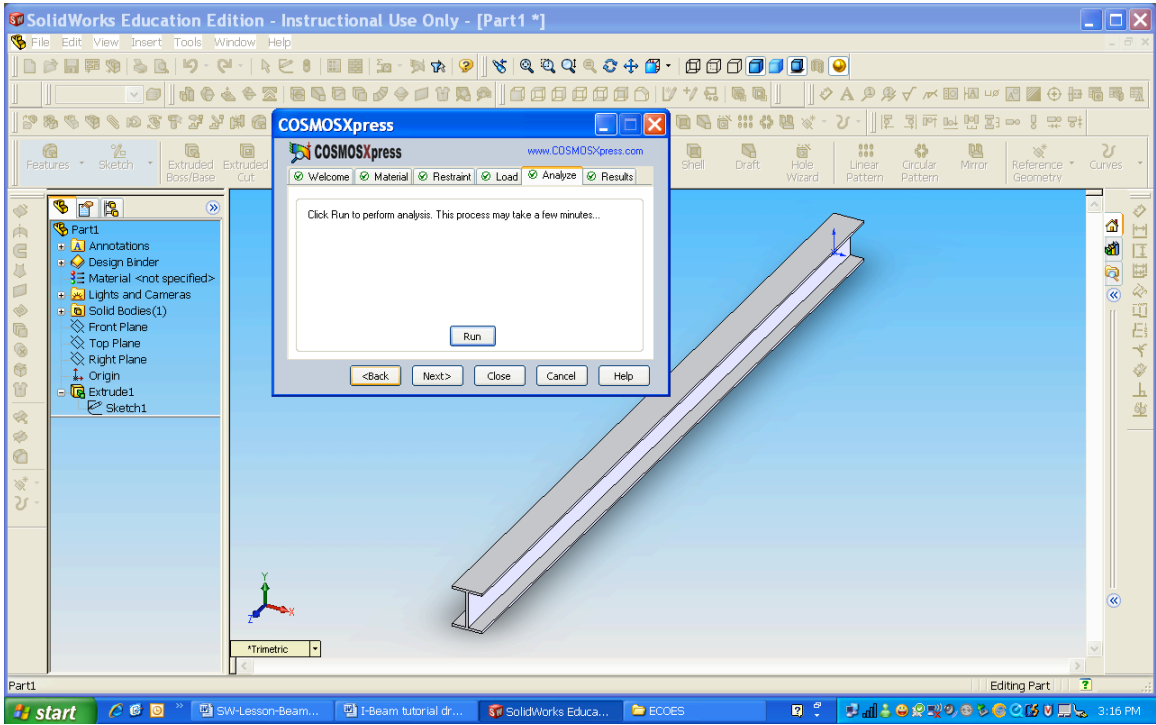

Once the simulation is completed you will see the screen below. By default, CosmosXpress starts the analysis in terms of FOS (factor of safety). Simply put, FOS tells you that the part will fail at locations where $FOS < 1$. To account for uncertainties in values, flaws in materials, etc, values for FOS are typically greater than 2. If a FOS is 'too large', then the designer may consider changing the geometry of the part as the design may be over-conservative. (However, there may be other reasons – for example, other loading conditions – that put further restrictions on the geometry.)

To see the results for the entire analysis, here enter a value greater than the FOS (for example, enter '11' for the current analysis)

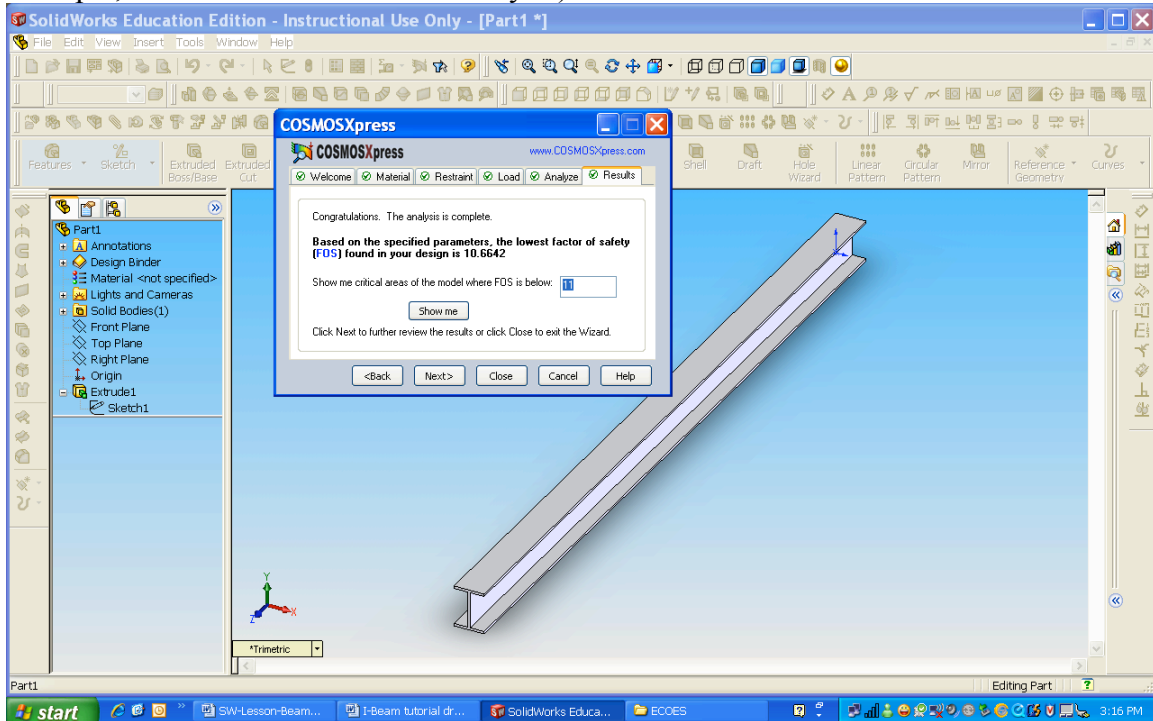

Click on “Show me the displacement distribution in the model” and click next

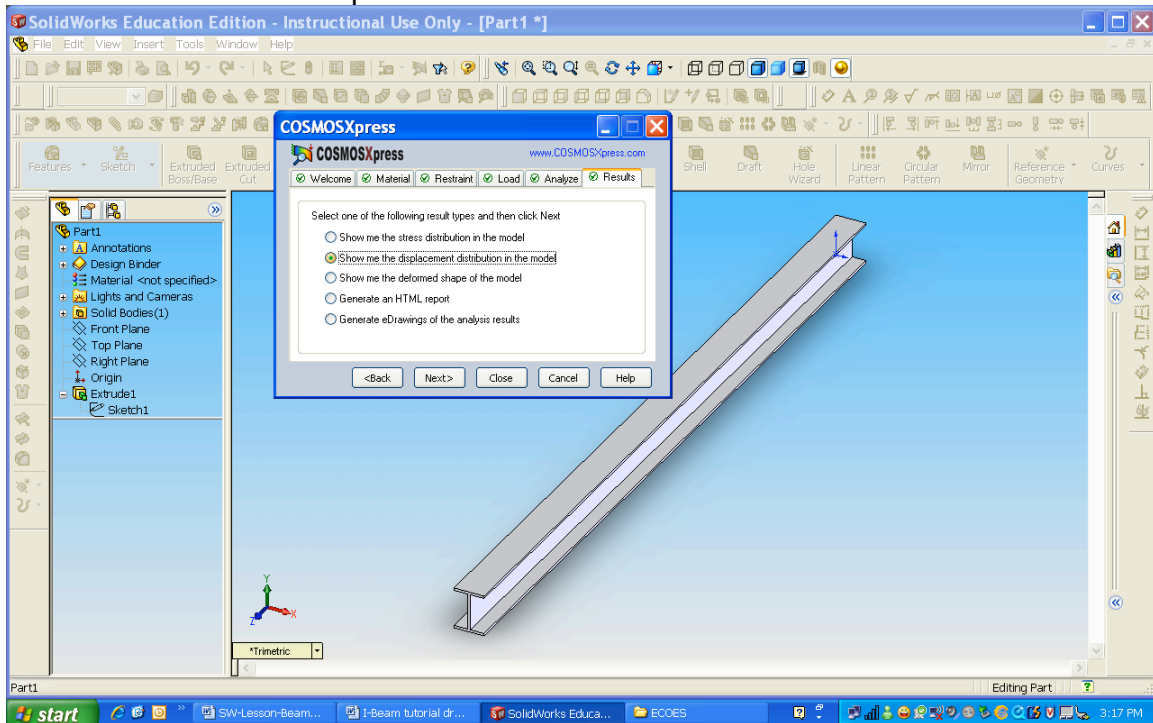

Press play to see the simulation

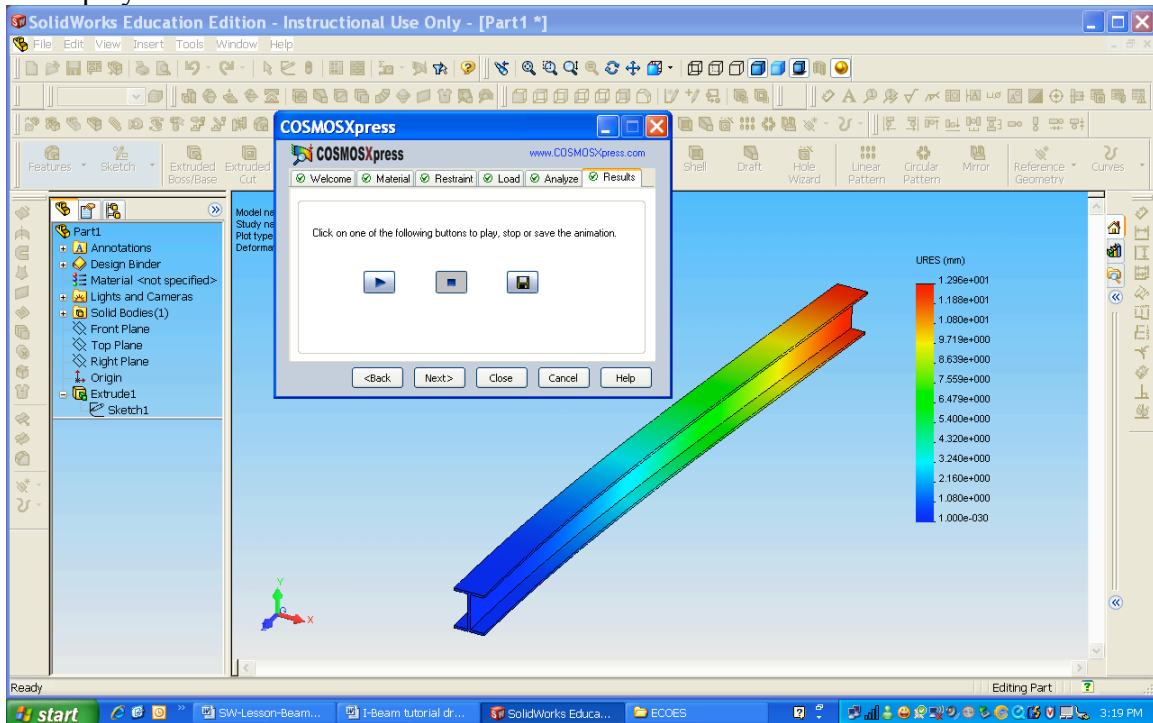

You can repeat the same procedure to look at the stress distribution

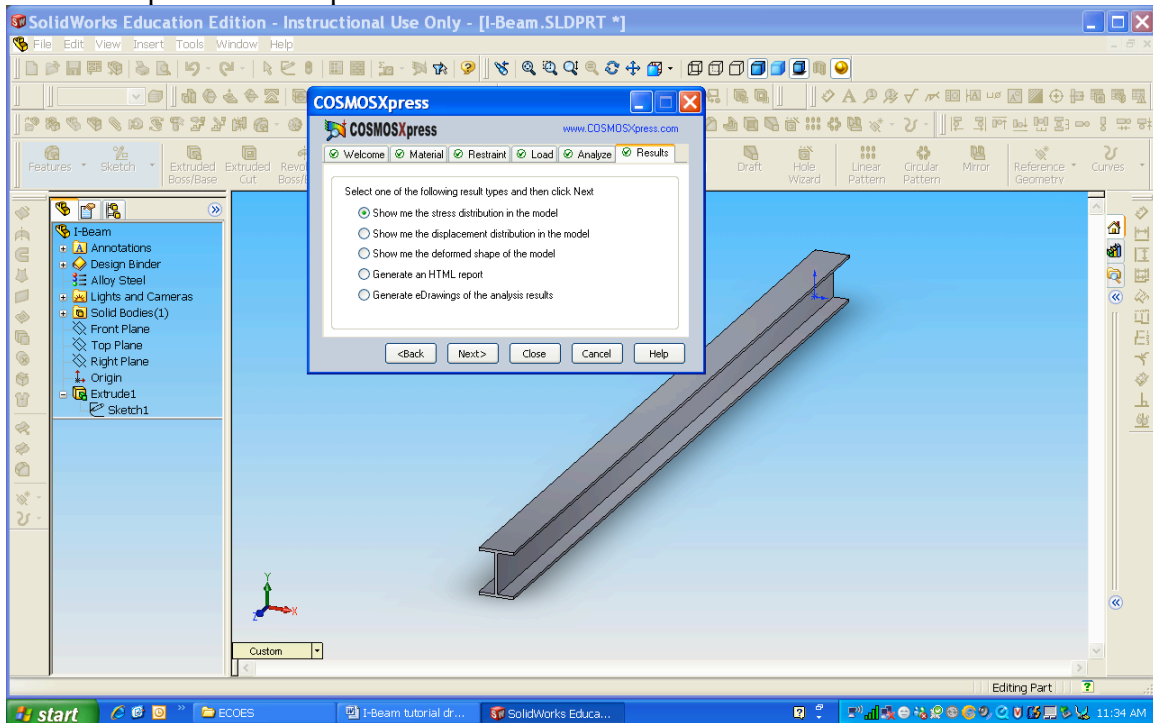

Click next to run the analysis

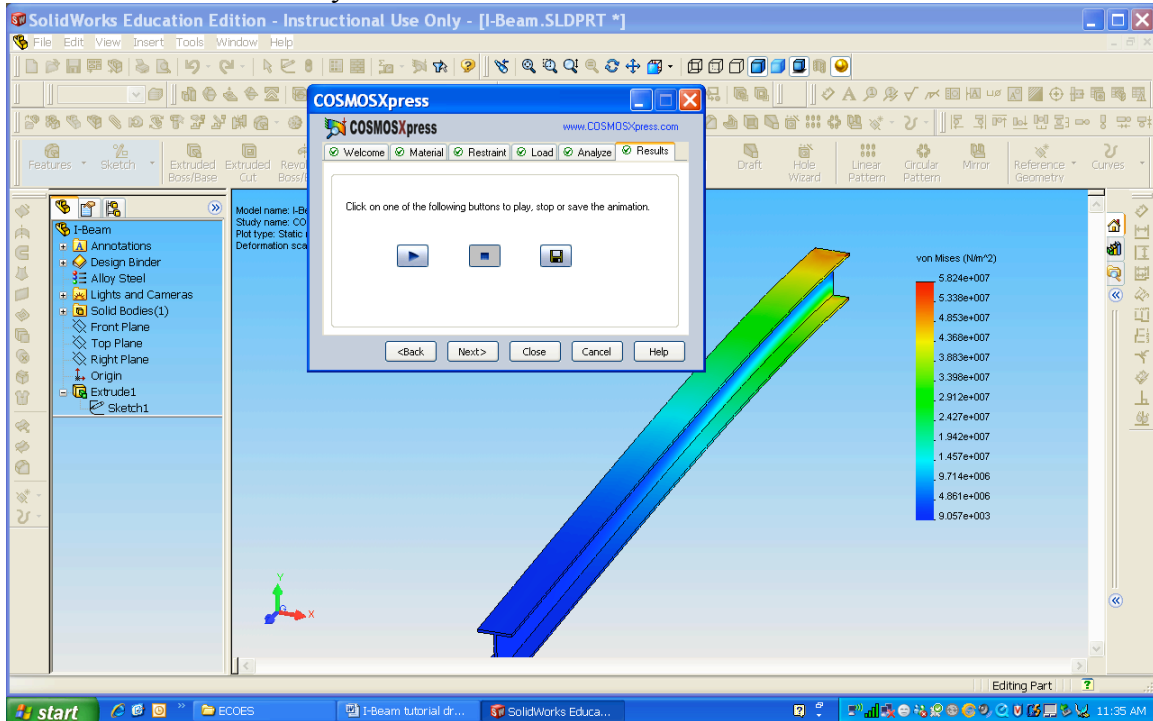

This gives you the stress distribution on the beam

For a Point Load at the end of the beam, go to CosmosXpress.
Go to the Load tab and delete the previous distributed load.

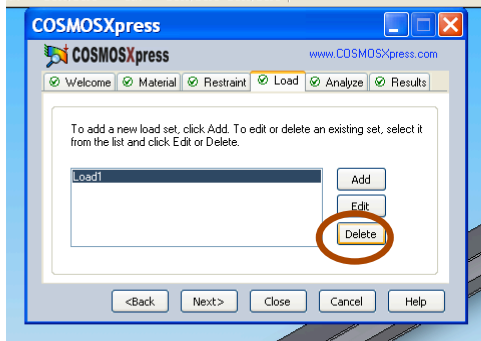

Click yes to deleting the load when the small window appears.
Click on Add to add a new force and click next.
Check force and click next as before.

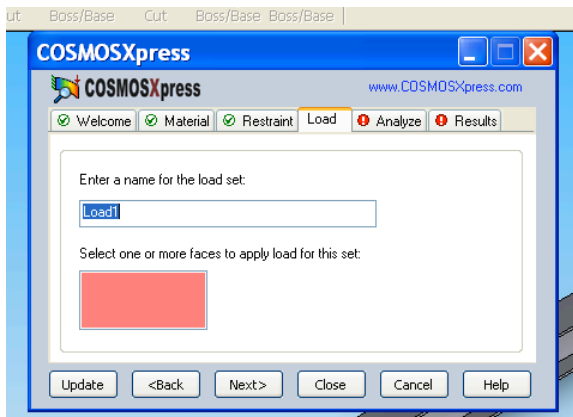

Click the other I shape at the other end of the beam and click next

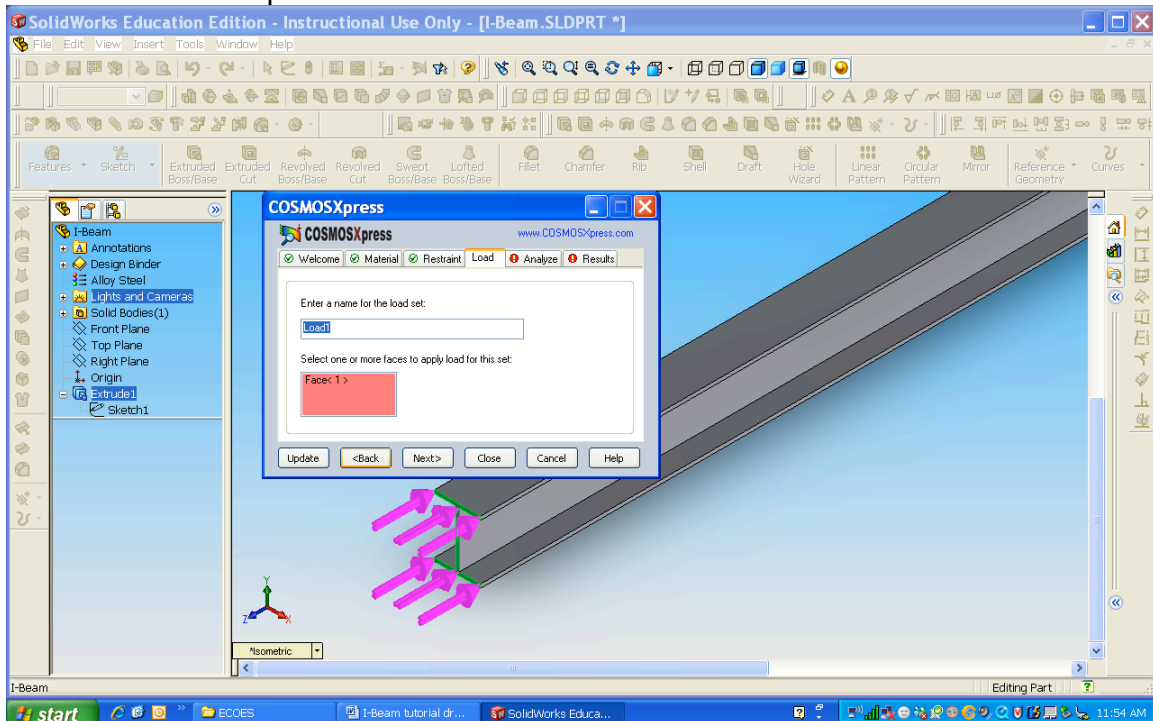

Select Normal to a reference plane and click on the top plane.
Select “Flip Direction” to reverse the direction of the beam.

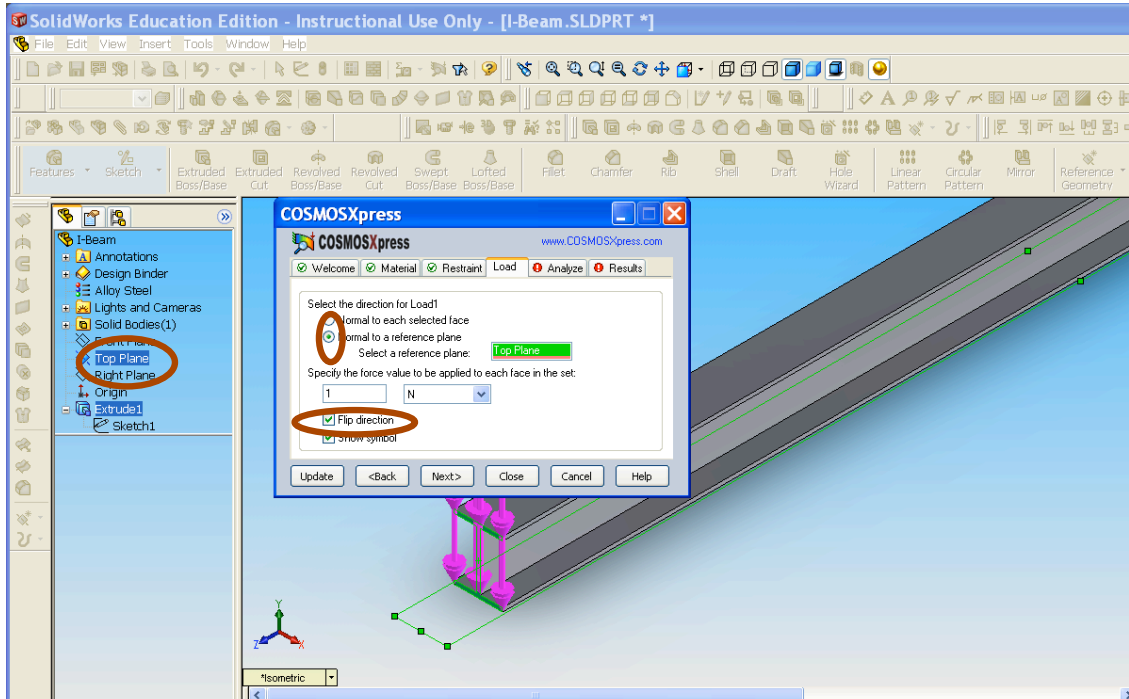

Repeat the same procedure as before. Analyze the displacement and the stress distribution and compare it to a distributed load.

Congratulations! You have completed this tutorial.

Now that you are done, can you try to...

- 1) What happens if you fix both ends of the beam (rather than just one end)? How does this effect the stresses and displacements? Does this make sense?
- 2) What happens if you change the material? How do the stresses in the structure change? How does the factor of safety (FOS) change? (Hint: do a Google search and compare the values of the Yield Stress for different materials.)
- 3) For the given initial geometry, calculate by hand the theoretical maximum force that can be applied given a Factor of Safety of 3.0. Apply this load within the software and verify that the stresses are the same.
- 4) What happens if you load the structure such that it acts like an 'H beam' rather than an I beam?
- 5) Change the cross-section of the beam so that you minimize weight but maintain a FOS of greater than 3 (keeping the load the same and maintaining a width of 250 mm and keeping the symmetry of the beam). Also allow the maximum deflection not to exceed 1.5 mm.