

Analysis of a 4 Bar Crank-Rocker Mechanism Using Solidworks Motion

ME345: Modeling and Simulation

Professor Frank Fisher

Stevens Institute of Technology

Last updated: Feb. 11th, 2010 By SJY

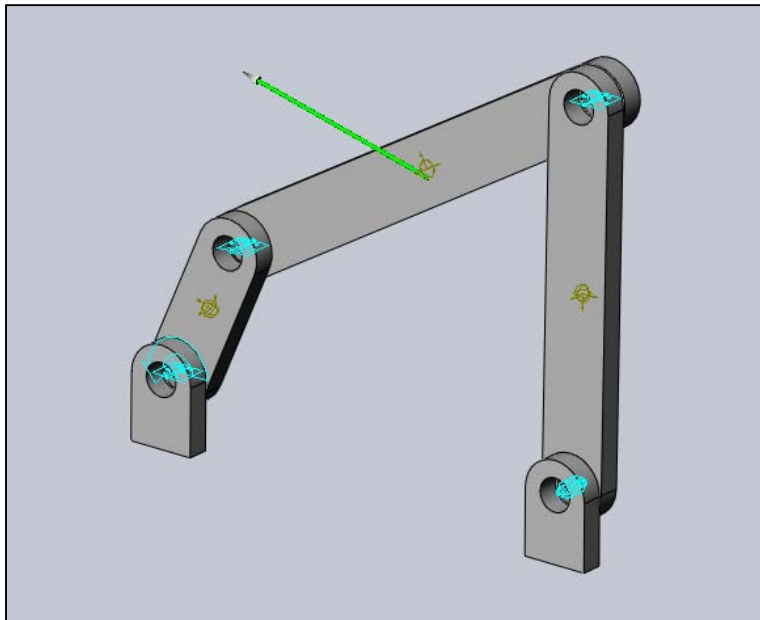

Table of Contents

1. Introduction
2. Creation of Linking Bars
3. Creation of SolidWorks Assembly
4. Simulation
5. Verifying the results
6. Further Work

Analysis of a 4 Bar Crank-Rocker Mechanism Using Solidworks Motion

Objective: To create a simple mechanism in Solidworks Motion.

Elements to use: Solid Works
Solidworks Motion
Four Bar Program
Dynamics/Machine Design Books

Description: This tutorial introduces students to Solidworks Motion Software, which is embedded in Solid Works. A simple four bar crank rocker mechanism will be used as an example.

Student will create the solid models by using Solid Works and later they will use Solidworks Motion to animate and calculate the absolute velocities on different points of these.

Solidworks Motion: This software is useful to study the behavior of Solid Works assemblies in motion, so that the designer can detect any design problems before building hardware prototypes. This software simulates the mechanical operations of motorized assemblies and the physical forces they generate

This software can perform the following calculations:

- Detect interferences between parts.
- Show forces and effects of collisions between parts.
- Output force data to Cosmos Works FEA Package for structural analysis.
- Use XY plots to graph quantities.
- Animate motion on screen in wireframe, hidden-lines removed or rendered display, and store as AVI or VRML files.

1. Introduction

In this tutorial, the motion of a crank-rocker 4 bar mechanism will be investigated using Solidworks Motion.

A four bar mechanism consists of 4 rigid links connected end to end creating a closed loop. Further, one of the links, called the ground link, is in a fixed stationary position. Four bar mechanisms can produce a large variety of paths of motion depending on the lengths and orientation of links. It is for this reason that four bar mechanisms are used for a large number of applications such as in manufacturing. You may remember from ME-358 (Machine Dynamics and Mechanisms) that the type of motion produced from a 4 bar mechanism is determined by the Grashof conditions. Grashof conditions will determine the type of motion based on the position and length of links in the mechanism. Determining the Grashof condition begins with the calculation of link lengths:

$$S + L \leq P + Q$$

Where:

S = length of shortest link

L = length of longest link

P = length of one remaining link

Q = length of other remaining link

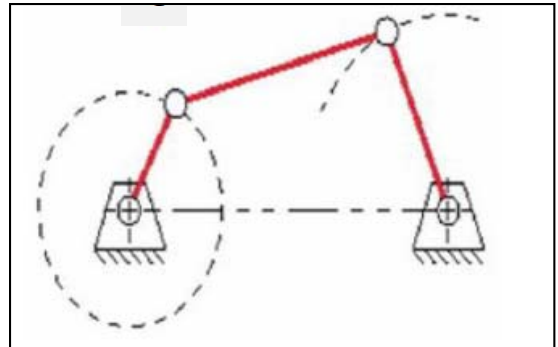

For a crank-rocker mechanism, the above equation can be simplified to:

$$S + L < P + Q$$

Further, the final constraint to be met is that the shortest link MUST be adjacent to the ground link.

Keep in mind that link lengths are measured from joint to joint.

Some common terms used in a crank-rocker mechanism:

Ground link – Described as the distance between the two ground supports. This link is always stationary. This link will be created through the use of distance mates in this tutorial.

Crank – The shortest link adjacent to ground link, freedom of motion allows for full 360 degree rotation. The crank is referred to as link 1 for this tutorial.

Coupler – Connects the crank and rocker links. The coupler is referred to as link 2 in this tutorial.

Rocker – Link adjacent to second ground link support. As the name indicates, this link is constrained to a back and forth motion. The rocker is referred to as link 3 in this tutorial.

A common application of the crank rocker mechanism is the windshield wiper:



Note:

This tutorial also utilizes the 4 bar program used in ME-358 to verify the simulation results. If you do not have the 4 bar program installed on your computer, you may want to do so at this point.

2. Creation of Linking Bars:

****Note****

Use the **Inch, Pound, Second** unit system

To begin, create the individual parts to be used in the assembly. The parts will be constructed using your own dimensions while keeping in mind the Grashof conditions for the crank rocker laid out in the introduction.

First, create the support:

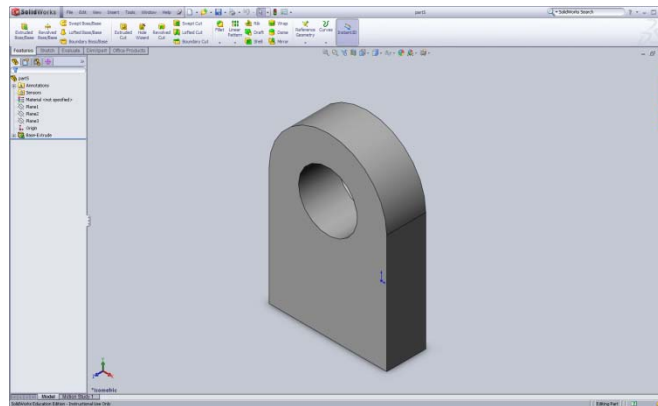

When completed, create a new folder to save the new parts. Save this part as **Support**.

When creating the links, be sure to make a note of the distance from the center of the two holes **for all links**. You will need this information when verifying your results later!

Next create the crank,

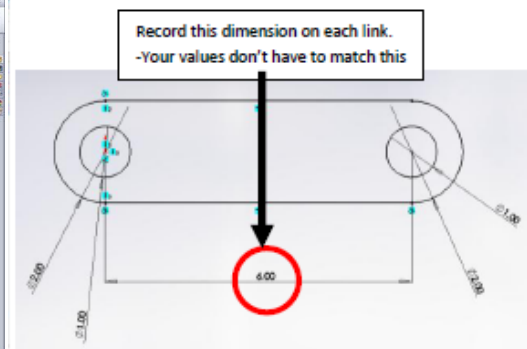
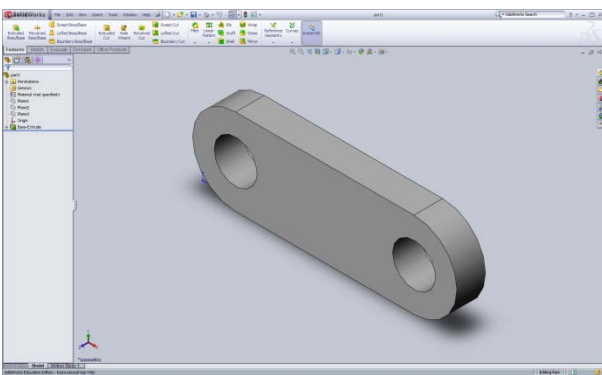

Remember This is the shortest link in the mechanism.

When completed, save this part as **part 1**.

3. Creation of Solid Works Assembly

Create a new assembly in SolidWorks, click on **Insert Component**, browse for the part called **support**. Insert the **support** part twice since there will be two supports in the mechanism:

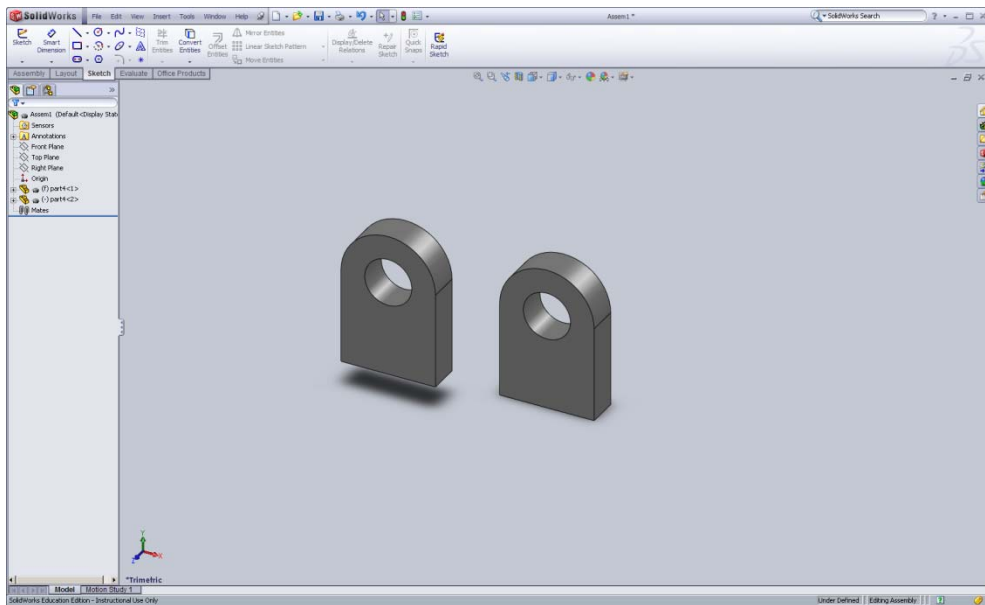
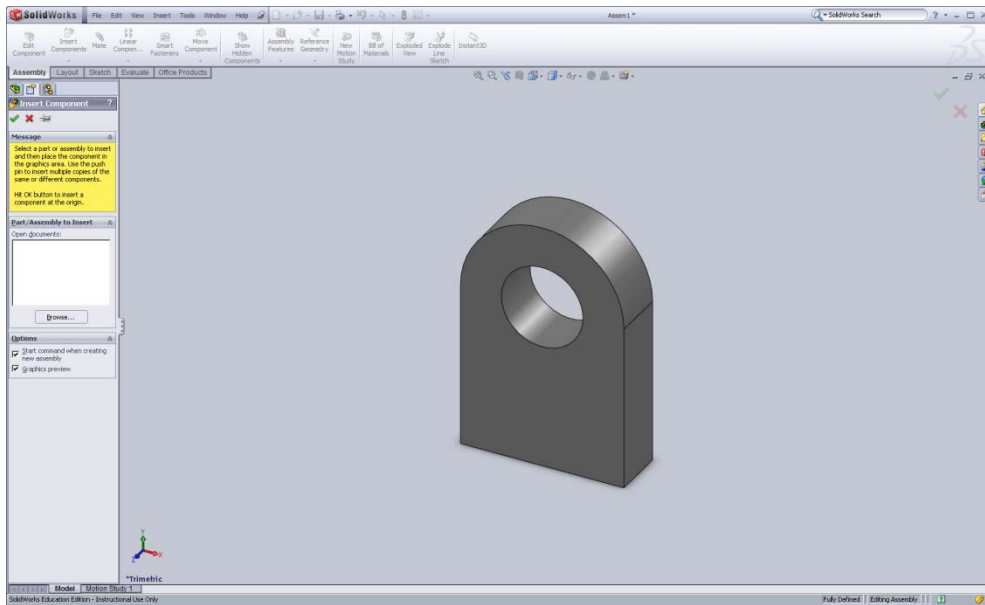

Select the front faces of the supports and click on the coincident button:

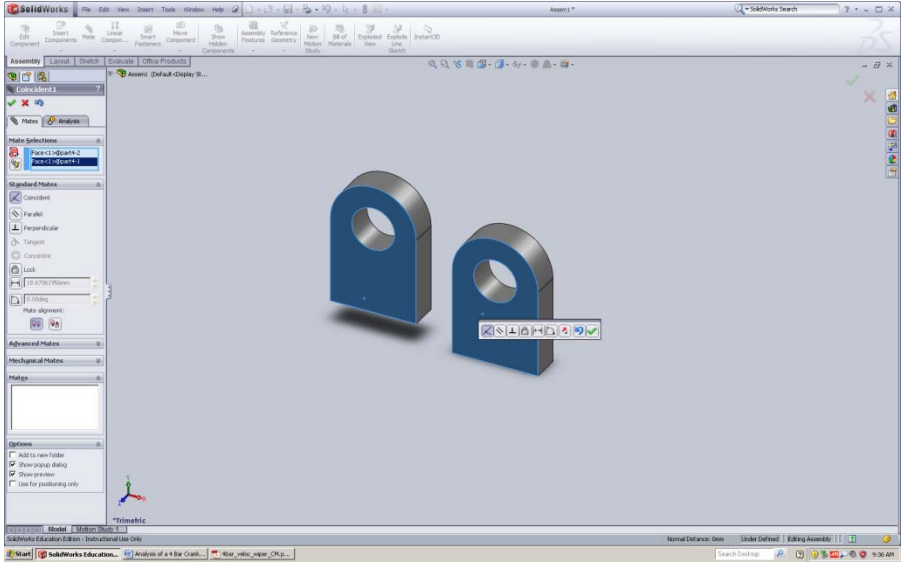

Now, click on the lowest faces (bottom) and select coincident again:

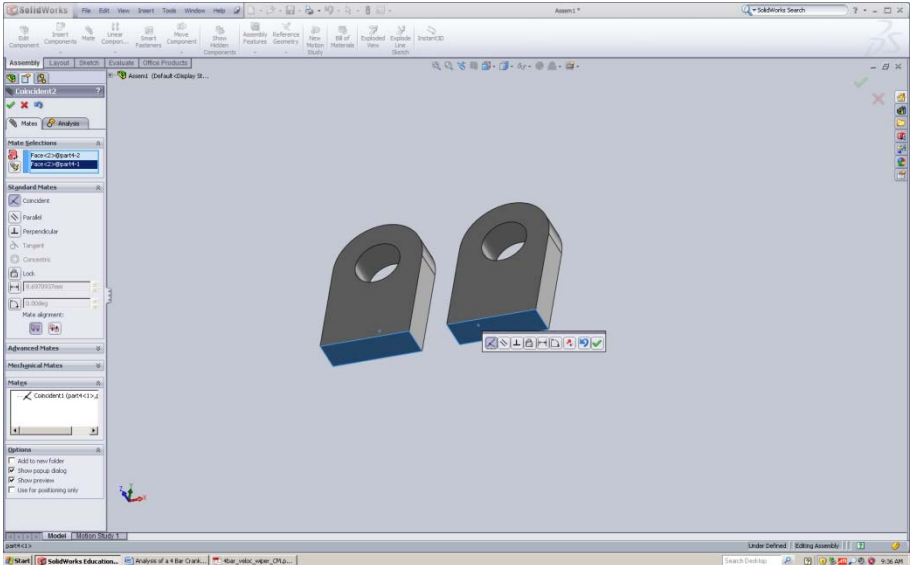

Highlight the circle at the edge of the support hole, trace the circle until the circle's center point appears in red. Click on the circle. Repeat for the other support. Create a distance mate that satisfies the dimensional constraints of the crank rocker mechanism. This defines the length of the ground link.

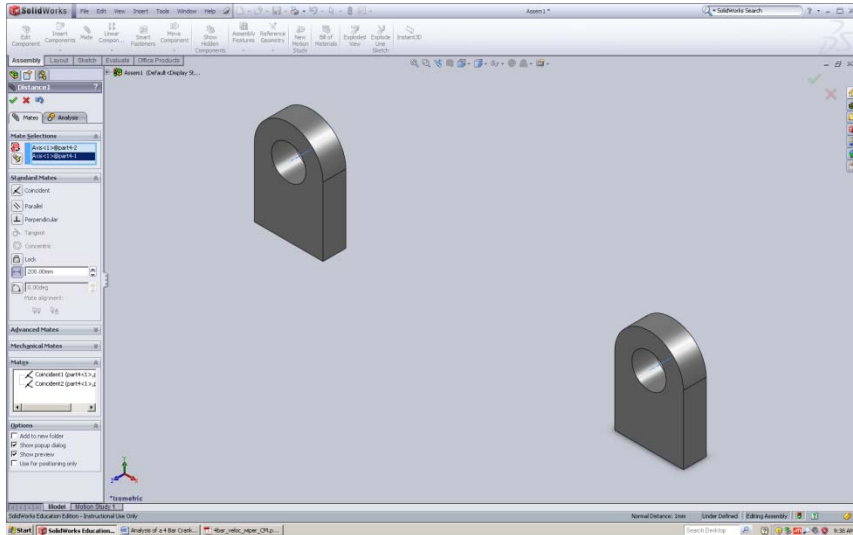

The parts 1, 2 and 3 will be assembled in their respective positions, the necessary constraints to create the mechanism are:

- Coincident
- Concentric

The concentric mate is useful here because it aligns the joints while allowing for full rotational movement.

For reference, the placement of the links in the final assembly should resemble the following:

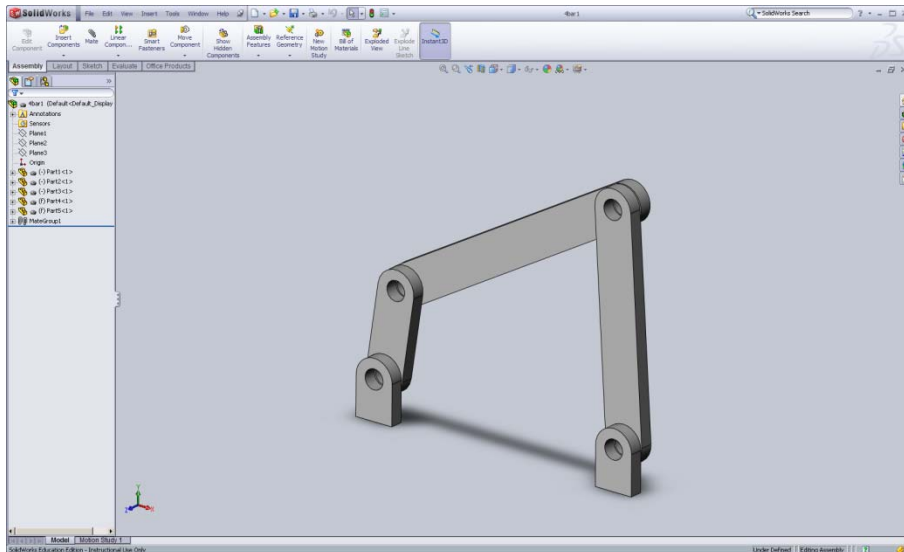

Open **part 1**, located in your part folder, and place it close to the support on the left:

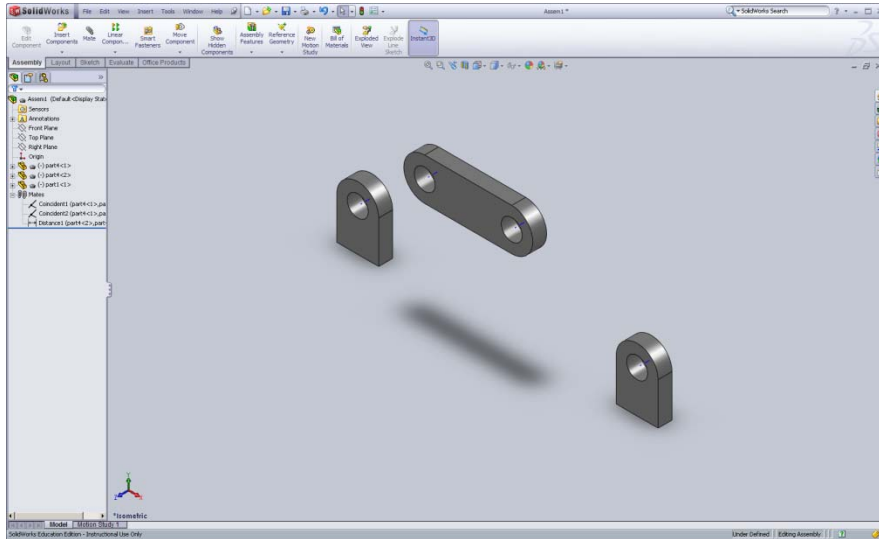

Select the opposite face of the **support** part (keeping the above graphic as reference), and the front face of the bar, and click on the coincident button:

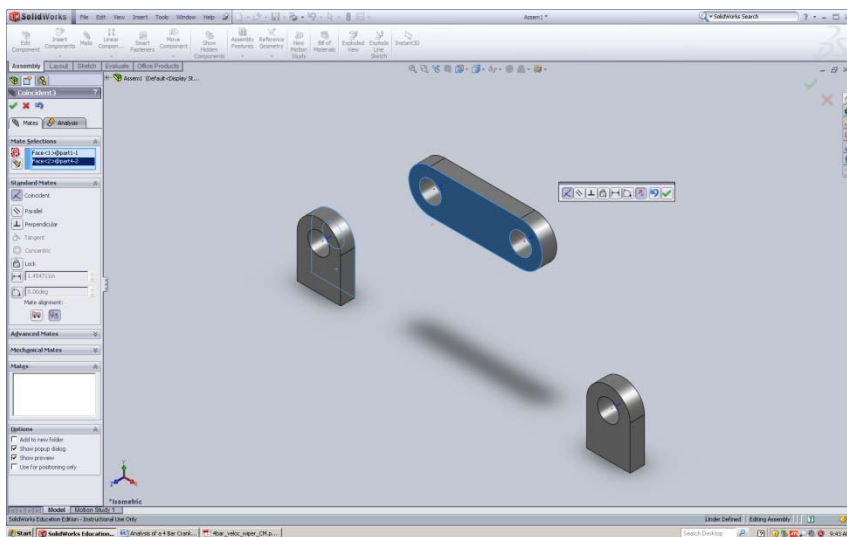

Now, select the internal faces of the holes (the bar and support), and select the concentric button, click the move component button and select the bar and move it to the best position to assemble the next one:

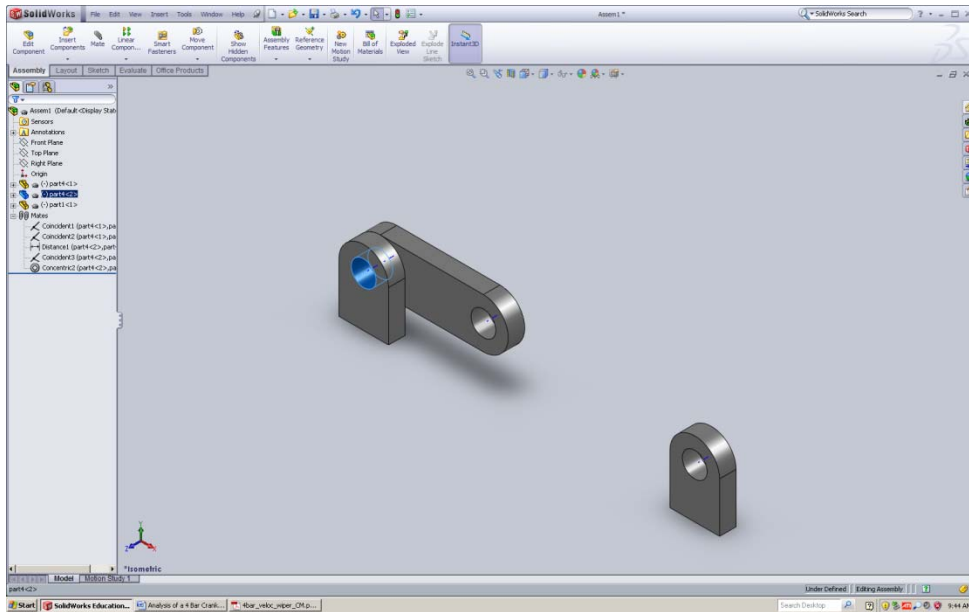

The procedure will be repeated with the parts two and three.

For **part 2**, select the front face and for the **part 1** select the back face:

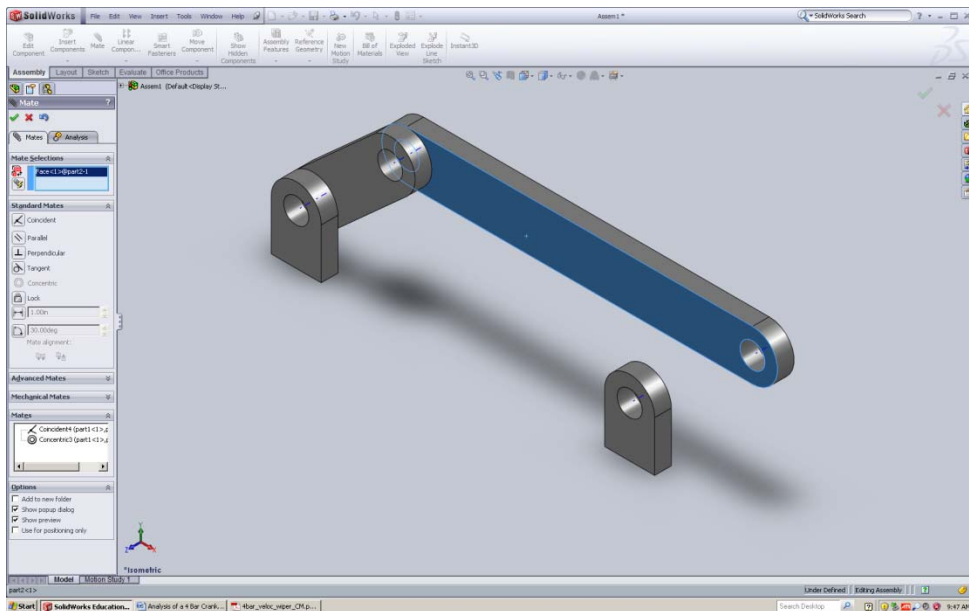

For **part 3**, select the back face, and the front face of **part 2**:

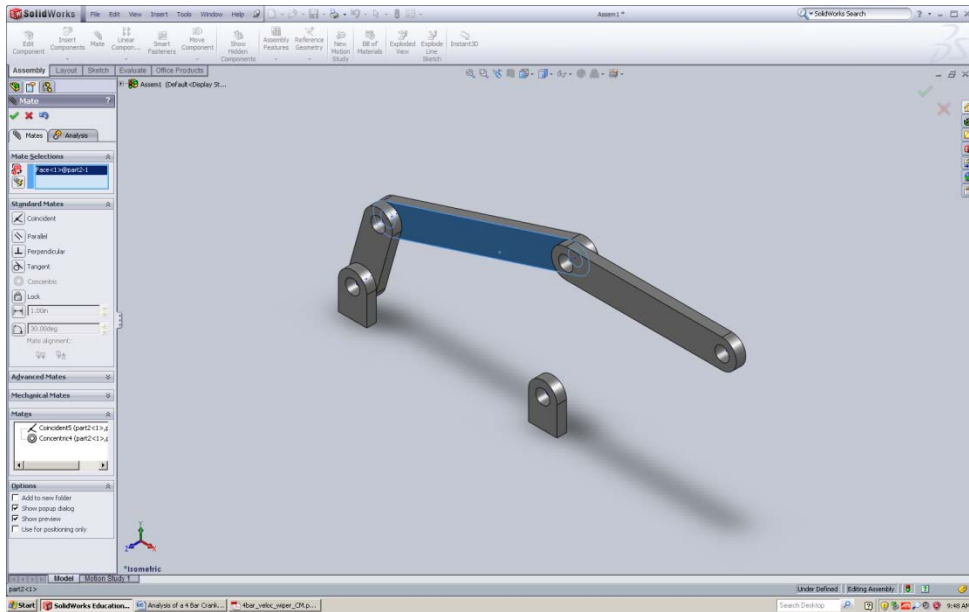

Select the internal faces of coincident holes and click concentric, repeat the procedure for the constraints between the third bar and the second support.

The mechanism should resemble the following picture:

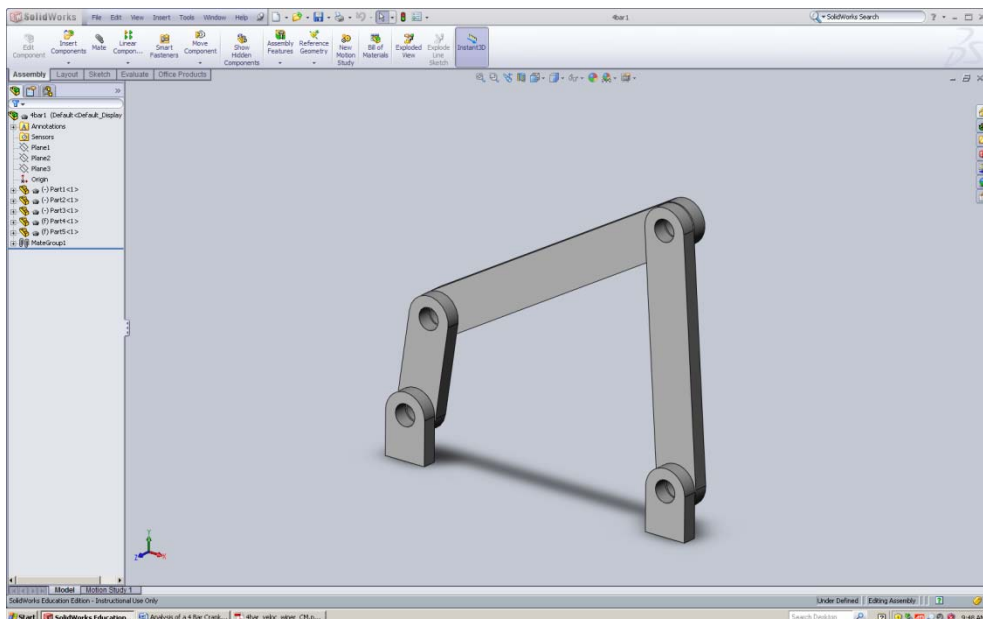

4. Simulation

If the “Motion Study” tab is not available at the bottom of your screen, click **View>Toolbars>Motion Manager**.

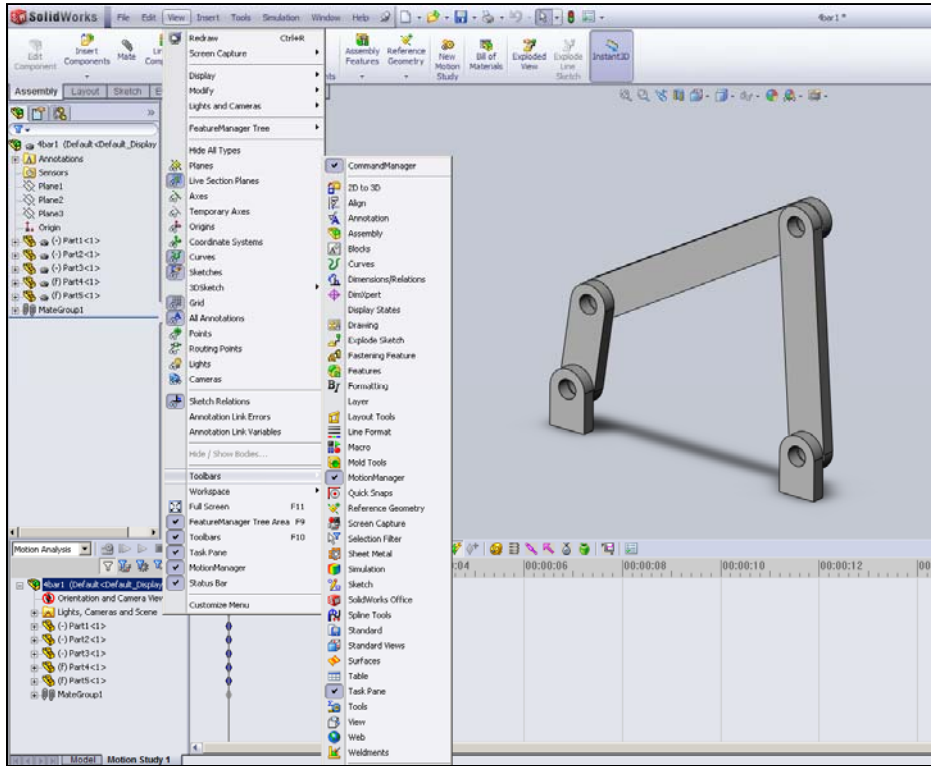

Right click on **Support 1** (located in the parts tree of the feature manager), and click fix. Repeat the procedure with **Support 2**. If the supports are already fixed, a lowercase ‘f’ will appear next to the part name in the parts tree and no further action is necessary.

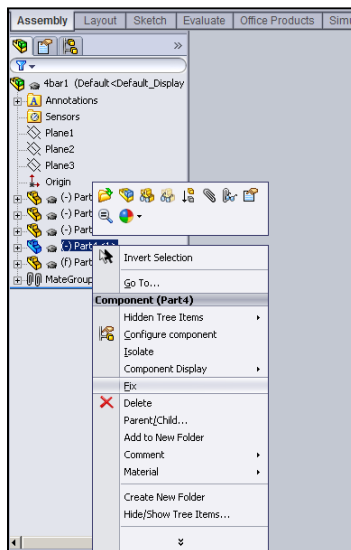



Automatically the software will assume some motion constraints according the assembly mate constraints that have been created. These motion constraints have to be checked.

Rotate the crank using your mouse, if the mechanism works, it indicates that the motion constraints are correct.

Click on the motor button  and add a rotary motor to the crank link (**part1**).

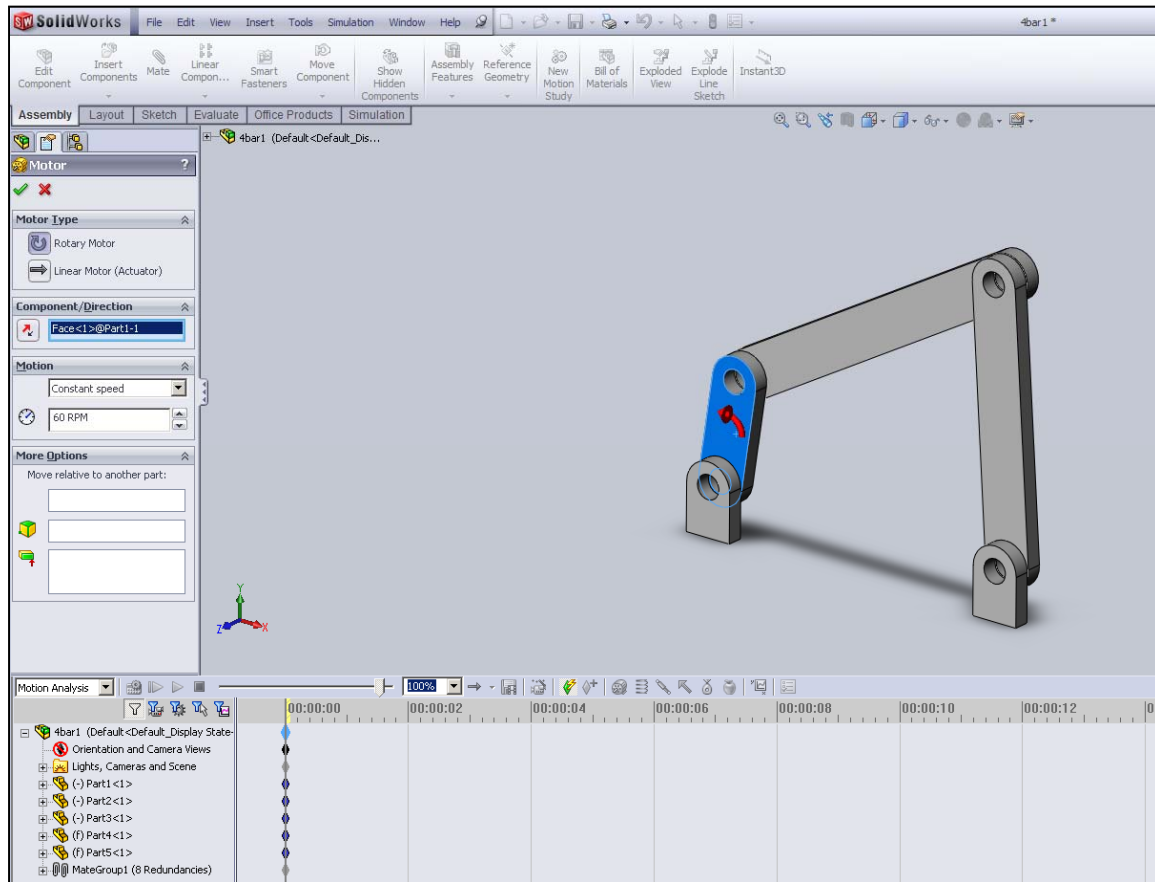
Select an angular velocity of 360 deg/sec constant speed (60RPM), click apply.



Click on the results button  the results menu opens on the left. In the three drop down menus, select **Displacement/Velocity/Acceleration**, **Linear Velocity** and **X-Component**. Select the coupler (**part2**), and click the check mark.

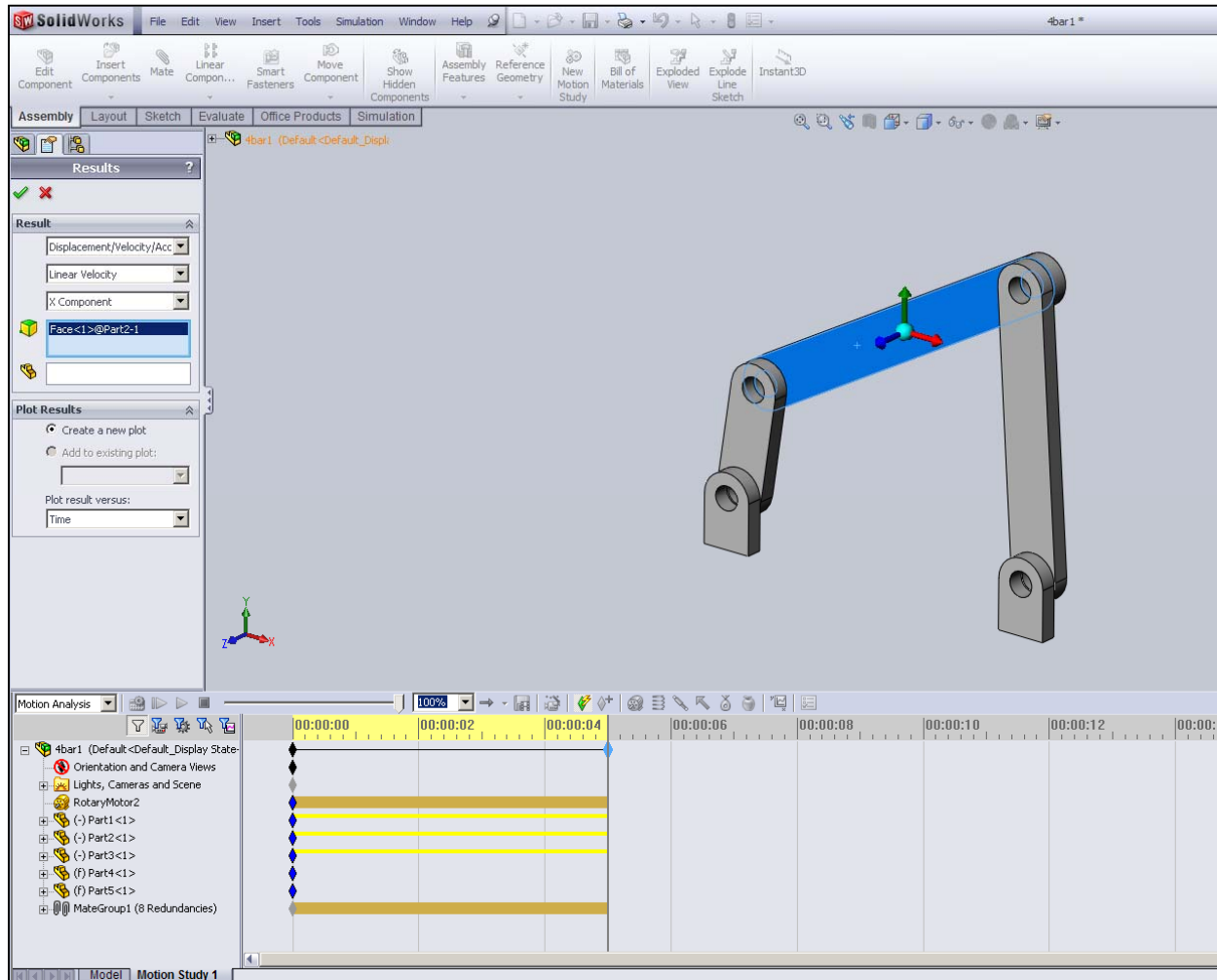

Repeat the same steps above for **Y-Component** and **Magnitude**.

Click on the calculate button  and the graphs below should be generated.

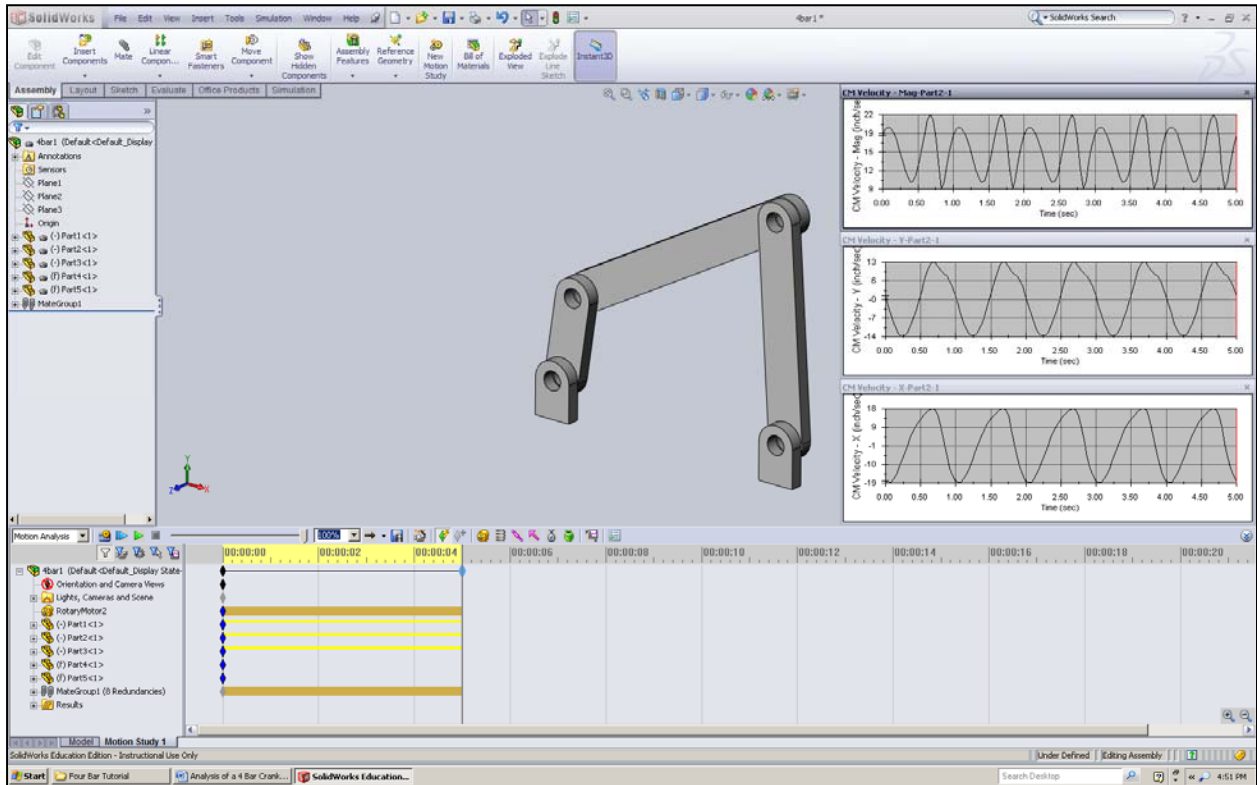

5. Verifying the Results:

One can verify that the results obtained above by using a different program; for example, the *Four Bar* program that is used in ME 358: Machine Dynamics and Mechanisms. The crank rocker mechanism will be constructed according to the dimensions used in the SolidWorks assembly.

Open the program, accept the user agreements etc. and start a new project. Enter the dimensional values for the crank, coupler, rocker and ground links. In the fourbar program, the ground link is labeled as “**Pivot O4 Coords**”.

Remember the link length is the distance from joint to joint.

Also, in the box labeled “**Dist to Coupler Pt**”, enter the length of the coupler link divided by 2. In the box labeled “**Angle to Coupler Pt**” enter zero. This will insure that the points where the velocities are measured will match you SolidWorks model.

In the box labeled “**Omega2**” enter **6.283 rad/s**. This is your crank velocity. In the box labeled **Min Theta**, enter the approximate starting position of your Solidworks Motion simulation. Add 360 to the **Min Theta** and enter this value into **Max Theta**. This will help to align you graphs.

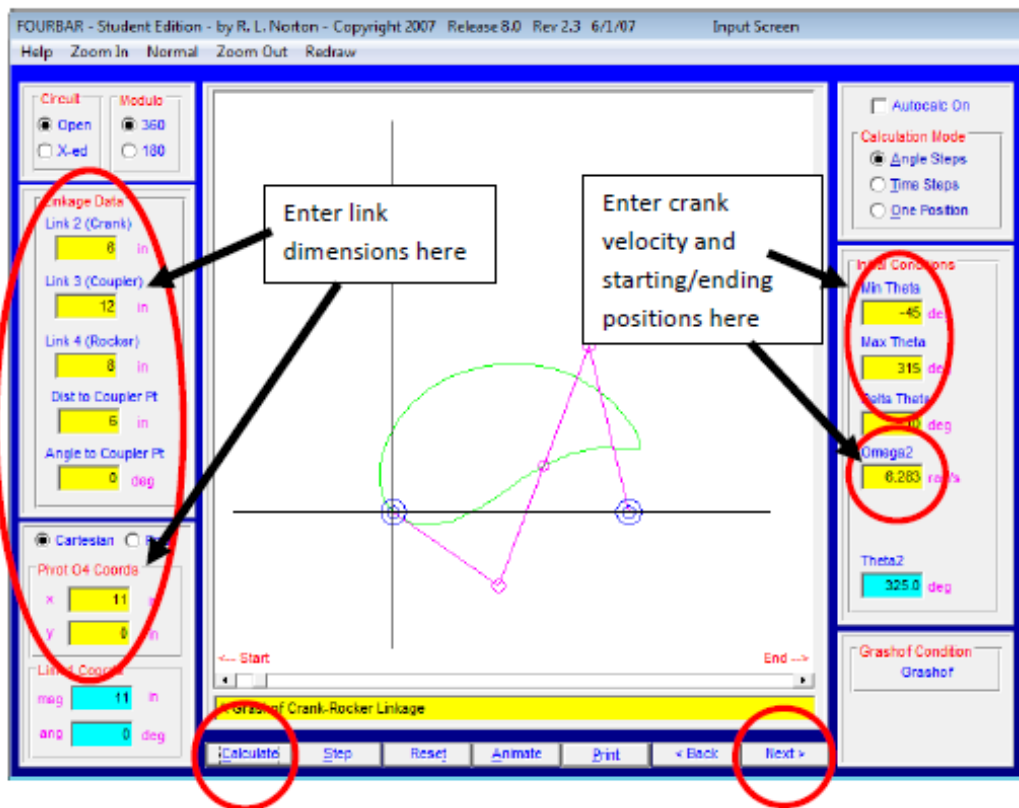

Click **Calculate**, then click **Next** twice.

Select **Plot** in the top center of the main window.

Click **Next** when this screen appears:

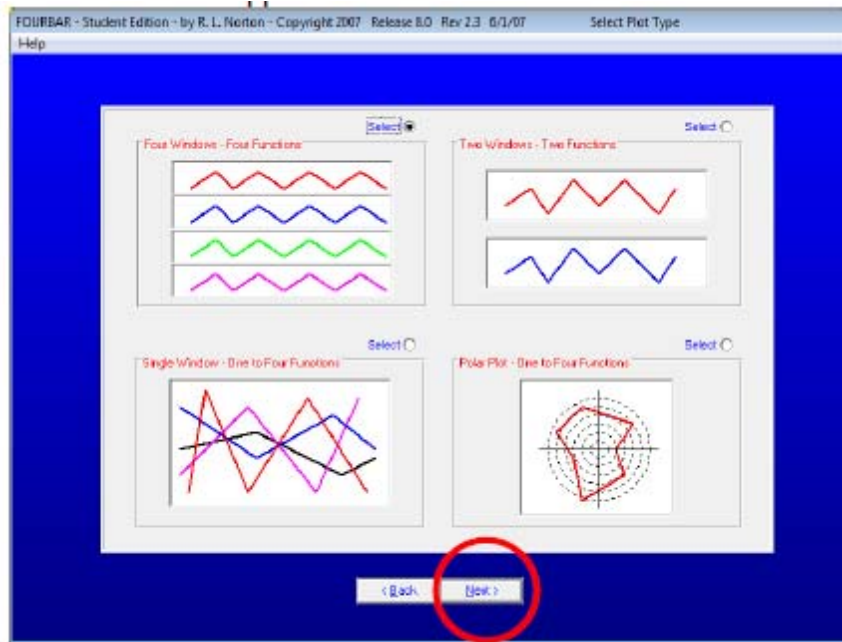

Select **Velocity of Coupler Point – X,Y,Mag,Ang Coordinates**. Then Click **Next**.

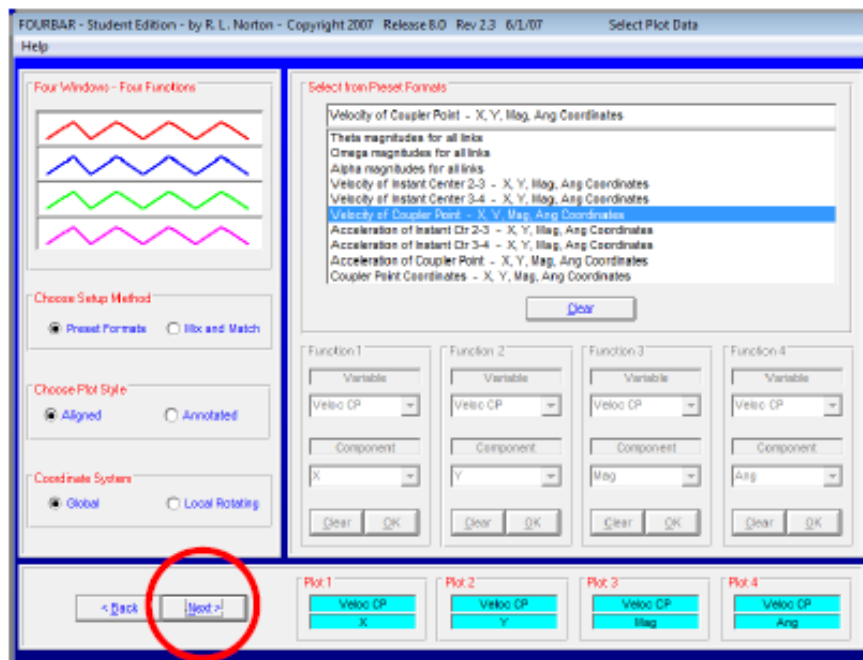

A series of graphs will pop up. The Max and Min velocity values should match.

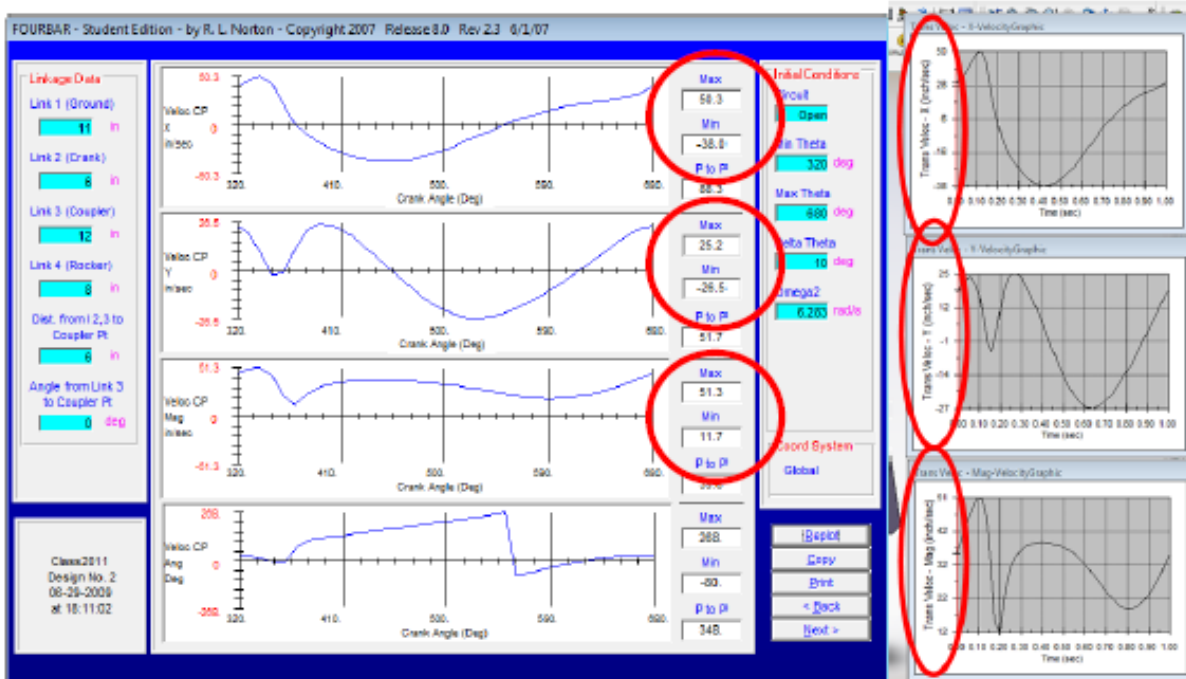

- What is the maximum velocity in the Y direction?
- In what period of time is the max velocity repeated? (Periodic time)
- What is the maximum Velocity (Magnitude) in the Coupler (Part 2)?

Next, return to SolidWorks and delete the plots for velocity. This time create plots of the **acceleration** for the X, Y, and Magnitude and repeat the procedure. Choose the **Acceleration of Coupler Point X,Y,Mag,Ang Coordinates** to plot the acceleration in the Four Bar program.

Finally, it is possible to export the SolidWorks data for use in Excel. To do this, right click: **Motion Model > Export to Spreadsheet** or alternatively: **Motion>Export>Excel(Spreadsheet)** Then, fill out the dialog box as follows:

- **Elements with Results:** Select the element whose results you want to view. Hold down **Ctrl** or **Shift** to select multiple elements.
- **Result Characteristic:** Select the type of result to export. Hold down **Ctrl** or **Shift** to select multiple elements.
- **Components:** Select the result component. Hold down **Ctrl** or **Shift** to select multiple elements.

Select **Add 1 Curve** to add the plot to the queue of curves to be plotted. You can repeat this process for all the result types you want to export.

- All curves added are plotted on the same plot in Excel.
- Selecting **New Plot** creates a new xy plot sheet in Excel. Any new curves are added to the new plot.

If you want to add more curves to an existing queued plot, select the plot name in the last text box in the dialog box. After you have specified all the curves and plots, select **OK** to create the plots in Excel.