

**Welcome to**

**Solidworks Simulation Tutorial**

**of**

**Torin **BIG RED** Aluminum Jack**



In this tutorial, we will use Solidworks Simulation to perform stress analysis on an aluminum floor jack built by Torin. We will apply a maximum load that this floor jack can handle as claimed by the manufacturer and see if this floor jack can actually support that maximum load without failure on any of its component.

## SolidWorks Simulation Tutorial

1) Open Big Red Aluminum Racing Jack.SLDASM.

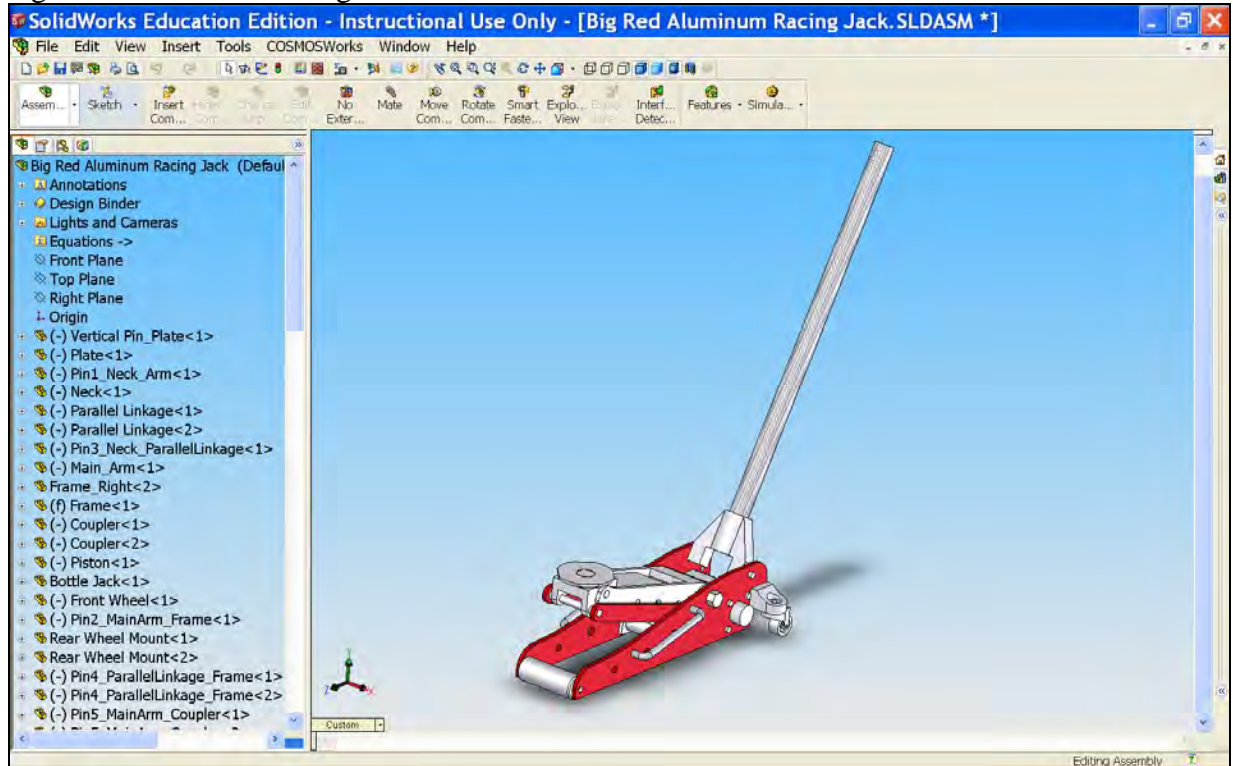

2) First of all, we need to suppress the front wheel, rear wheel assemblies and handle. To suppress all of those parts simultaneously, left-click **Front Wheel** and ctrl+left-click **Rear Wheel Assembly <1>**, **<2>** and **Handle**.

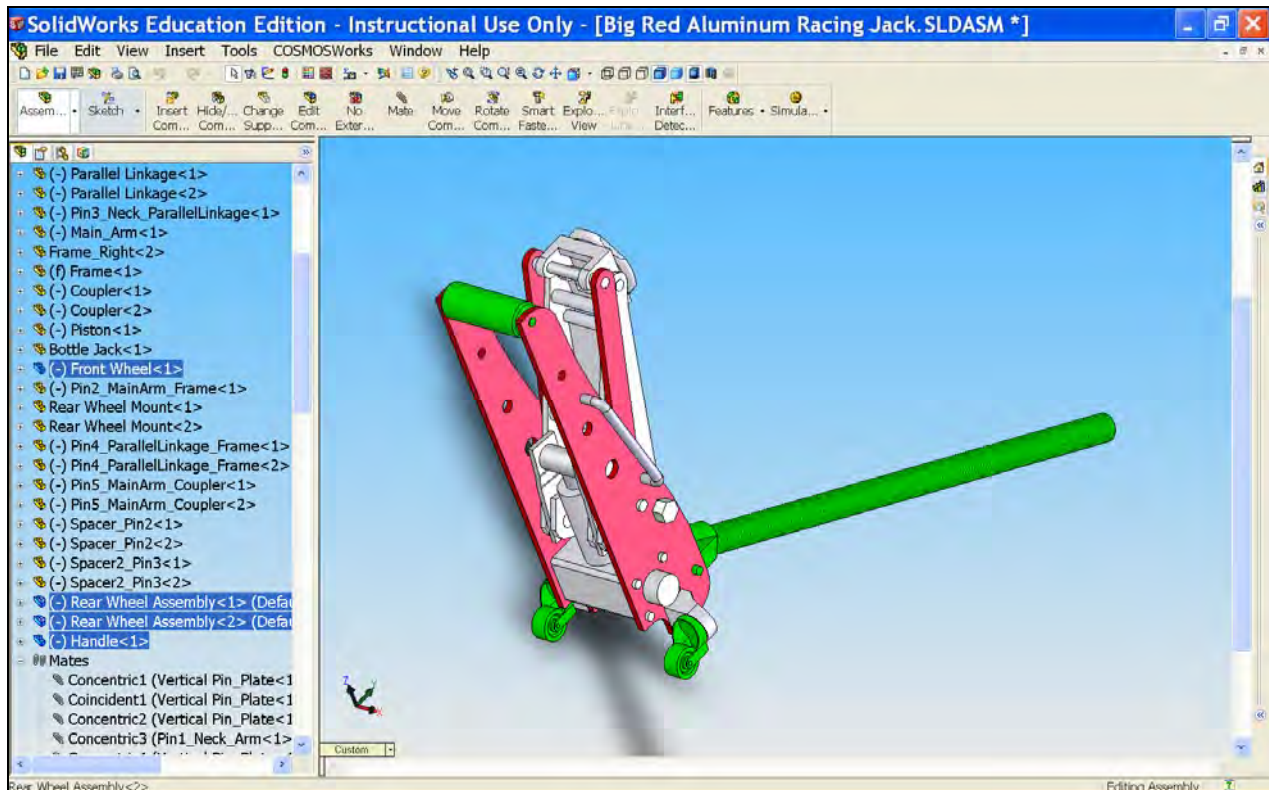

3) Now, right-click and select  **Suppress**.

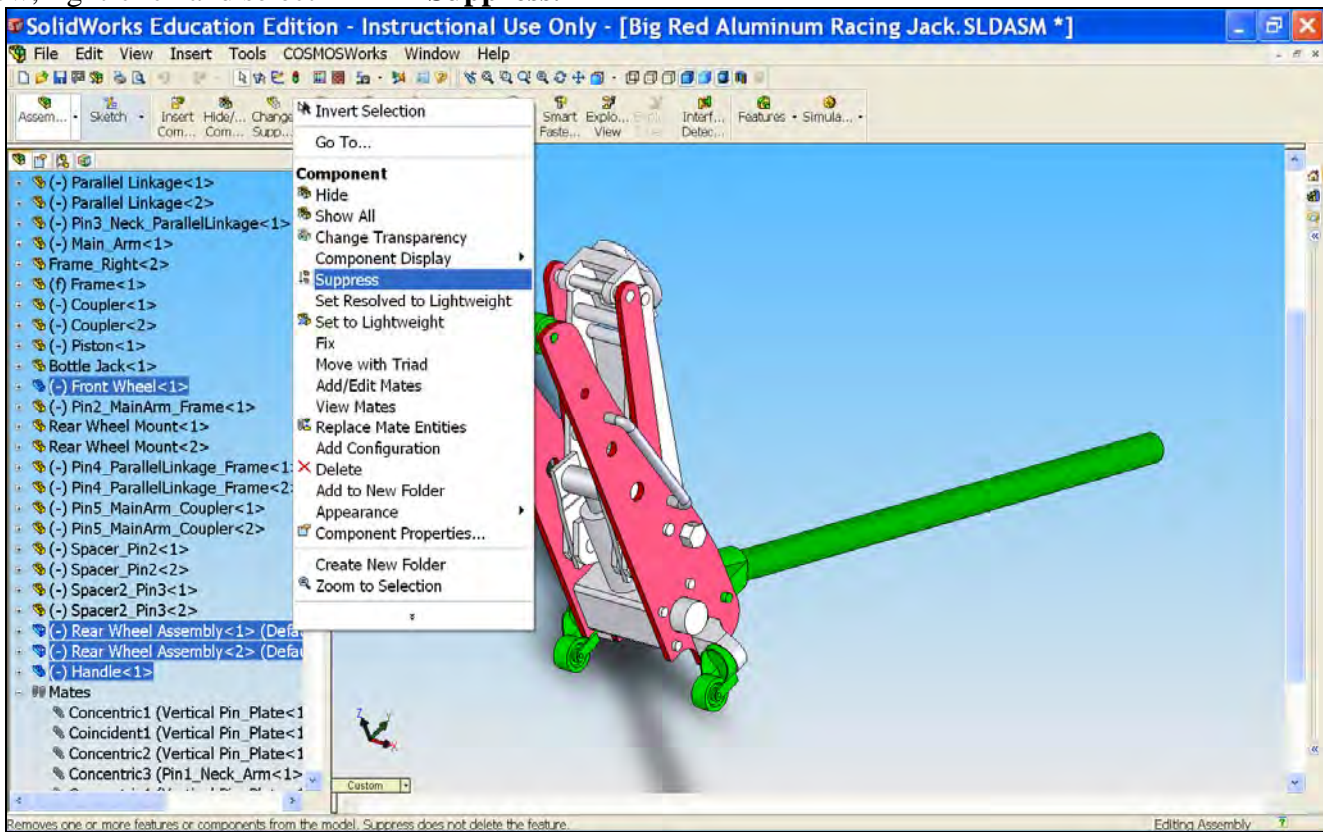

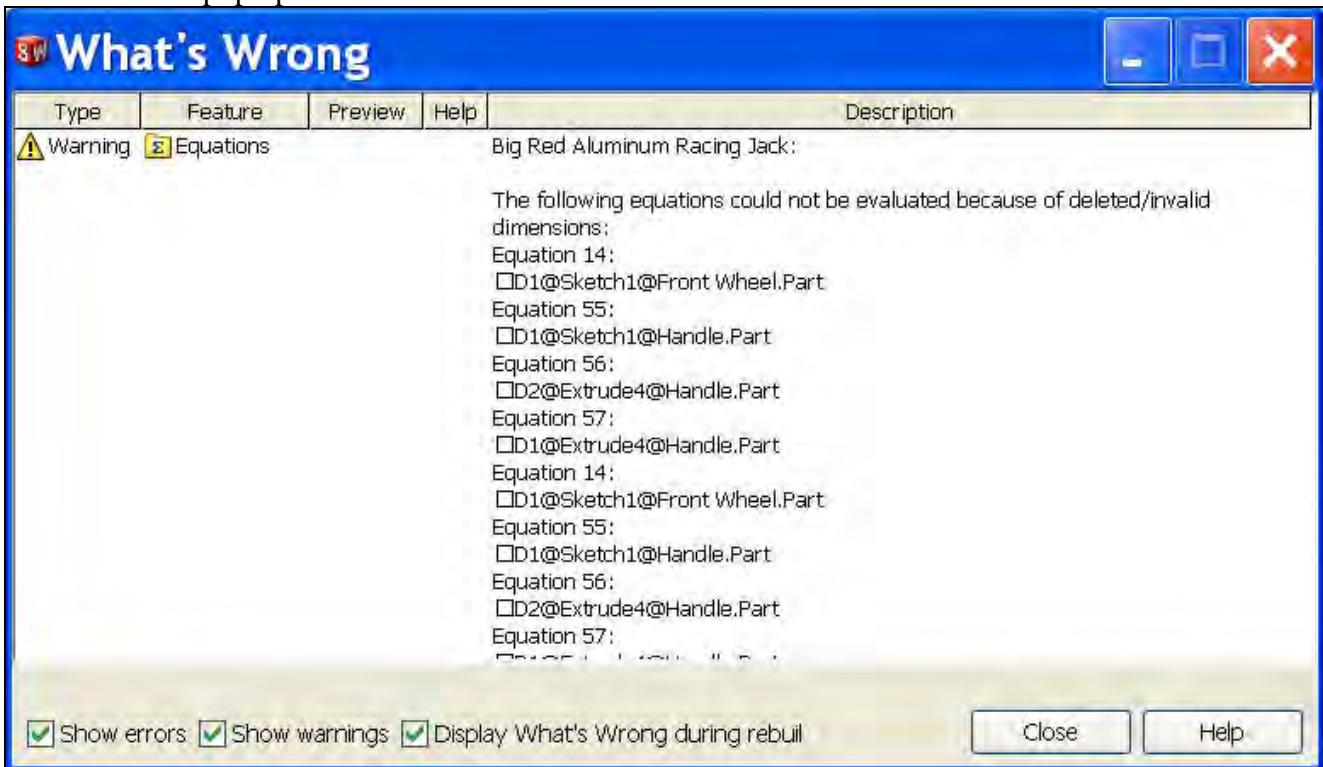

4) This window will pop up. Click close.



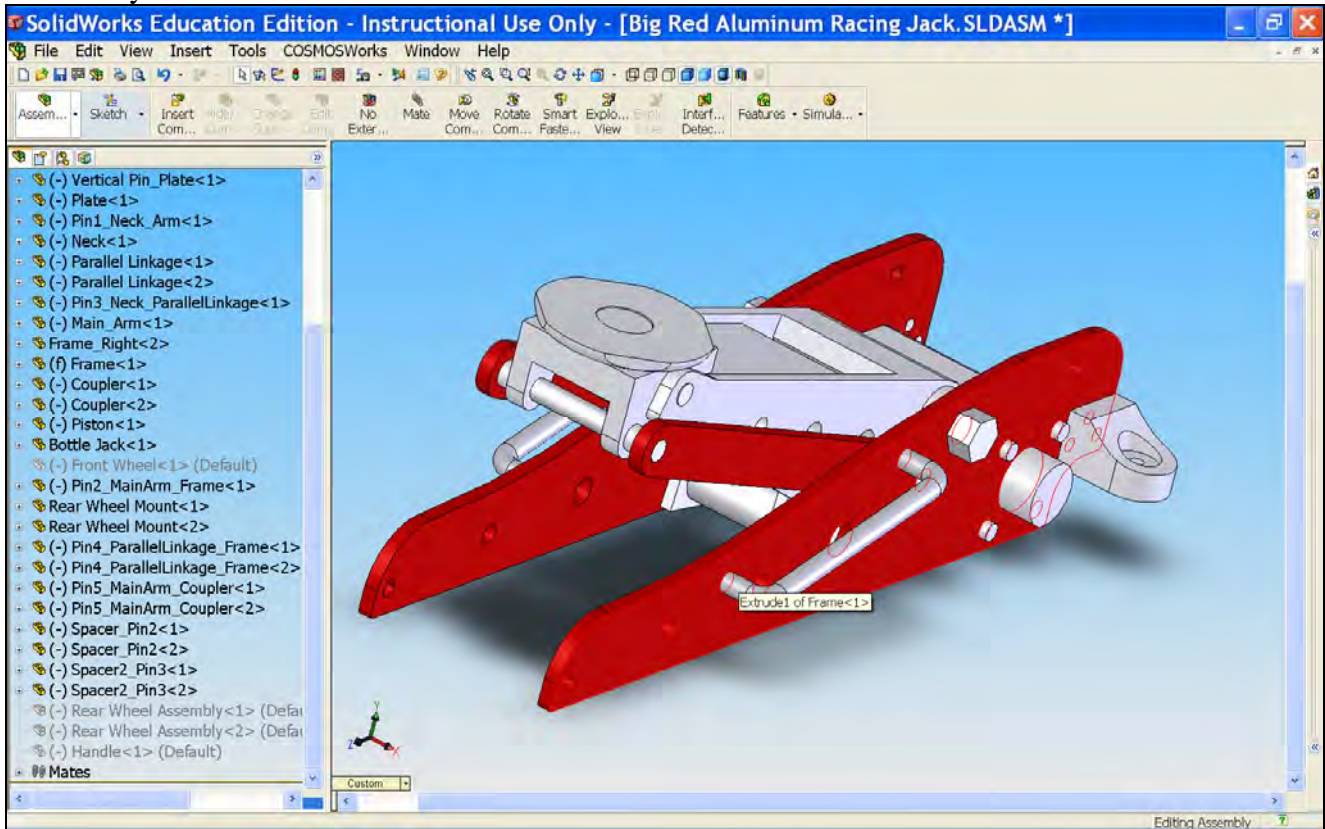

5) The assembly should now look like this.



6) Now, we will define a distance between the plate, which supports the load from a car, and the ground. For this case, we assume the bottom surface of the frame as the ground. Click on  **Mate**. The Mate window will appear on the left. Under **Mate Selections**, we can first select top surface of the plate as shown in the picture below.

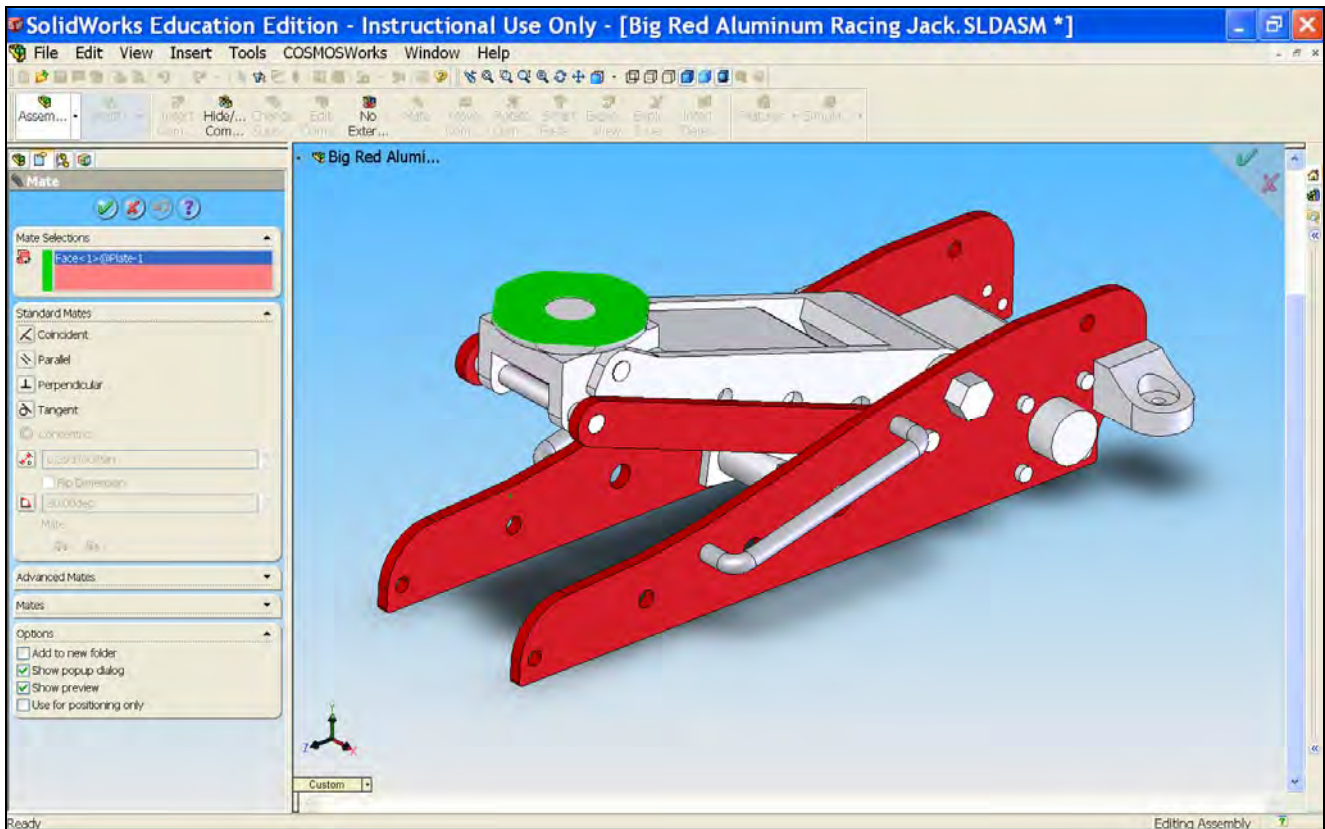

7) Second, select the bottom face of the frame as shown in the screen shot below. Under **Standard Mates**, click on



**Distance** and set the value to 4.1".

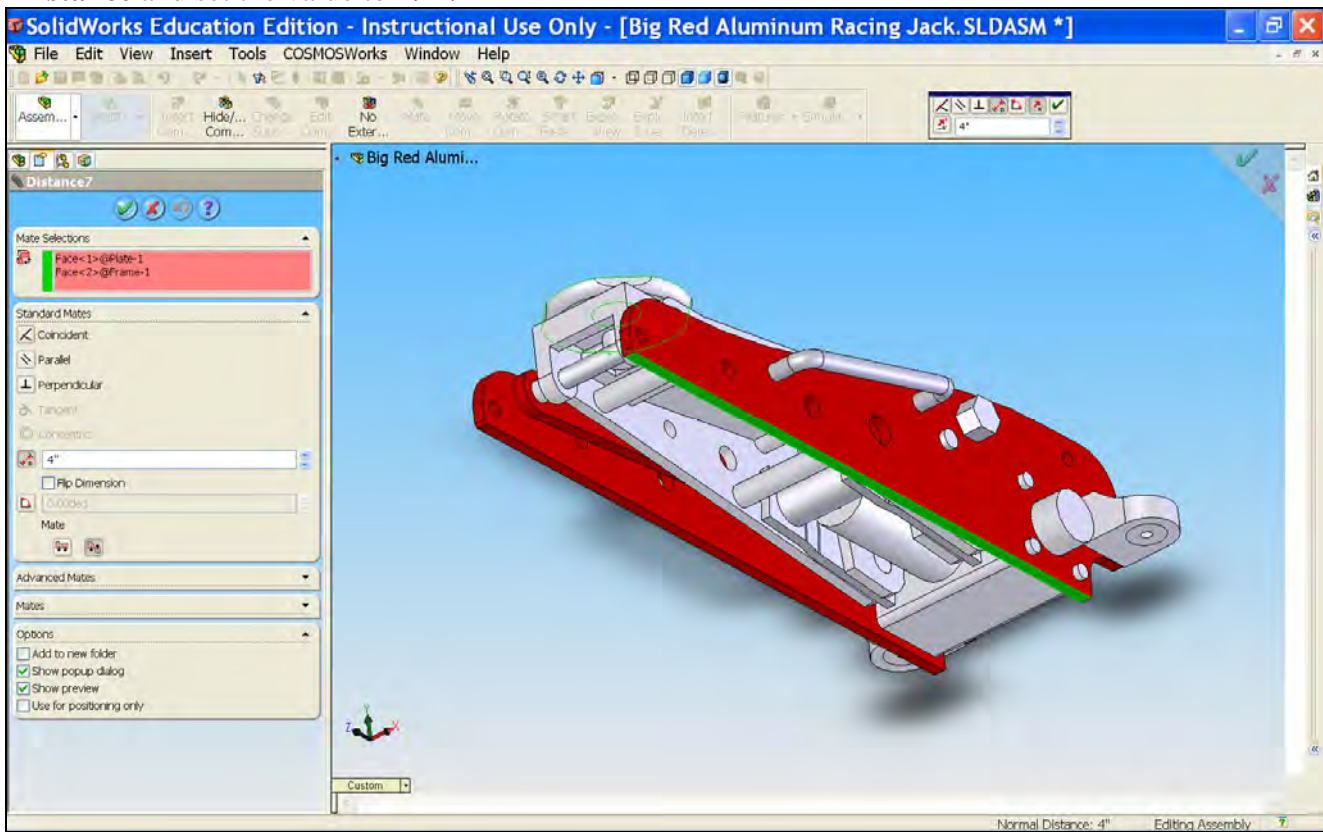

8) The top face of the plate and the bottom face of the frame are now 4" from each other. Now we will use SolidWorks to analyze the stress on the floor jack assembly when the load is applied. Click on the Simulation tab

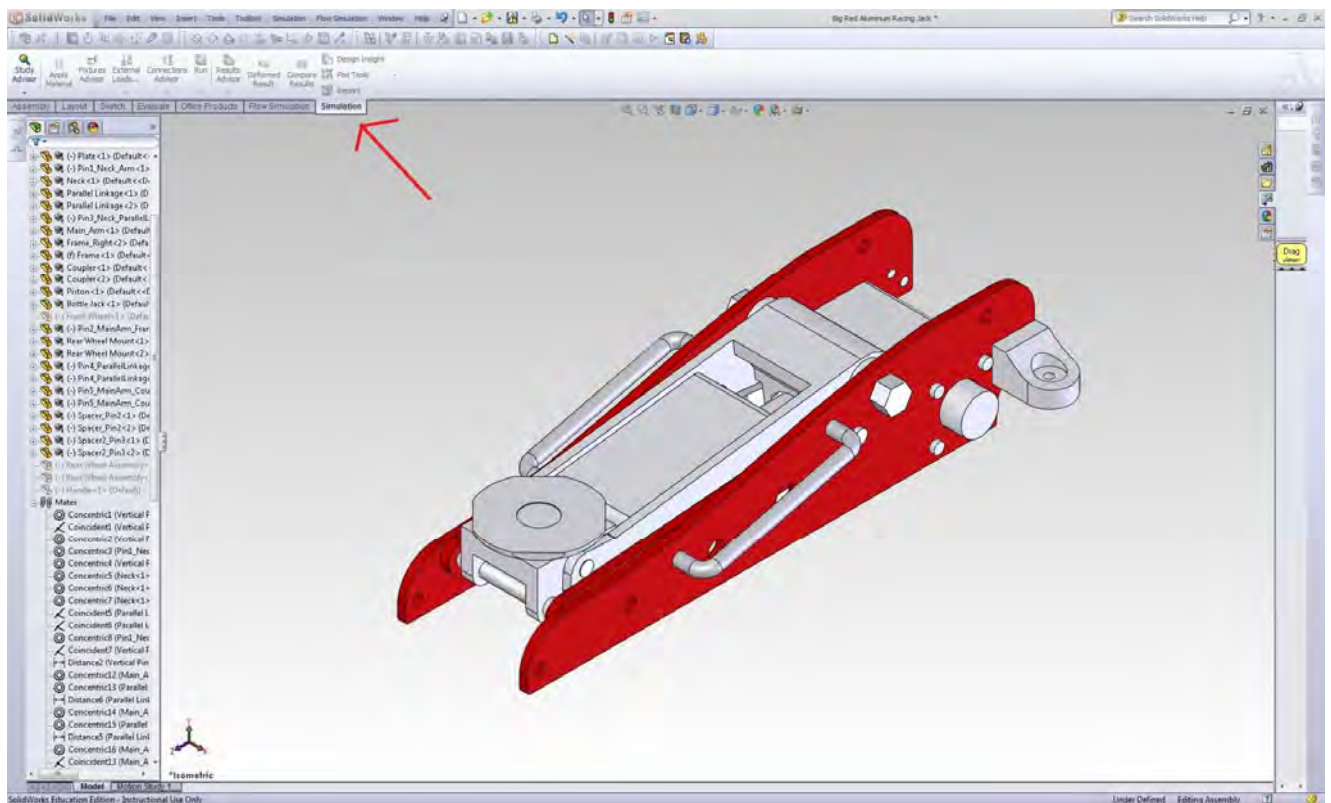



9) Click on 'New Study'.

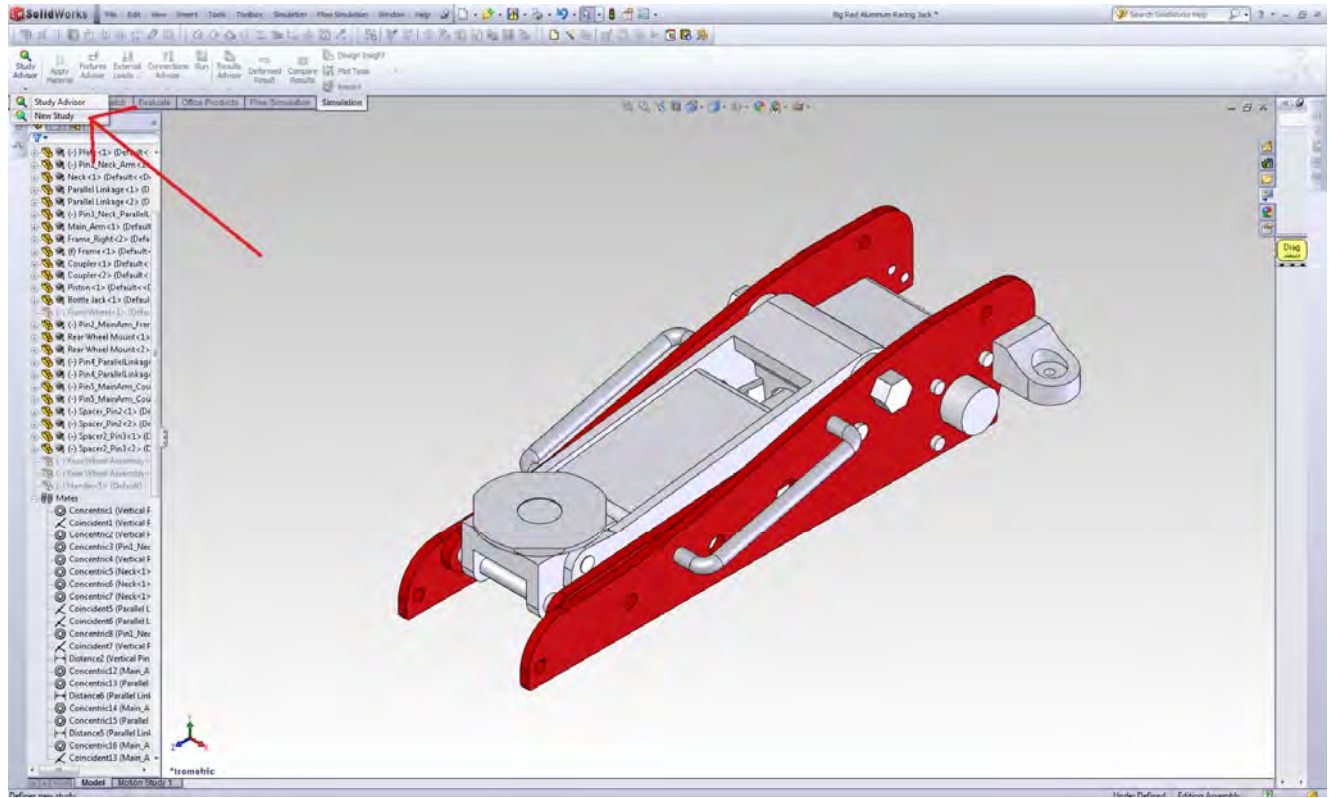

10) Under Type Select **Static**

11) The SolidWorks study is now created.

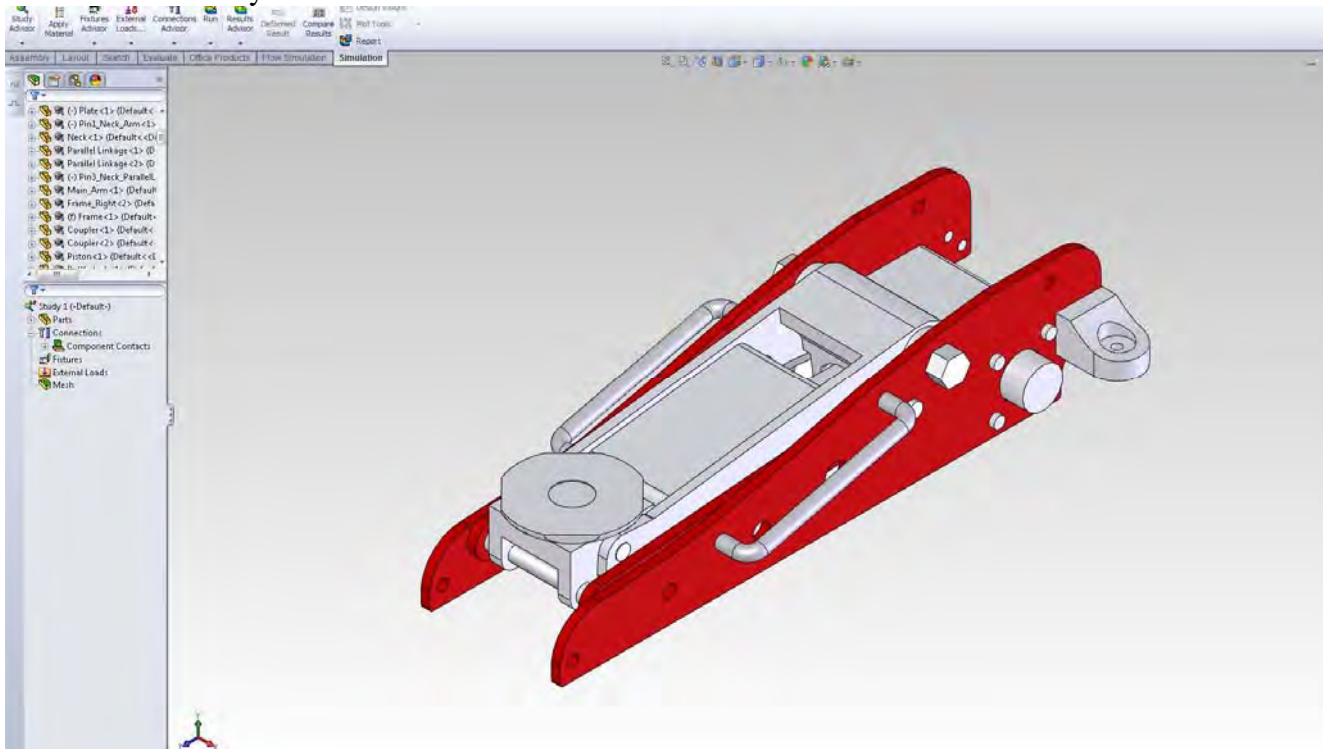

12) Now, we need to assign material for the floor jack assembly. Under Study1, right-click Parts and select **Apply Material to All**.

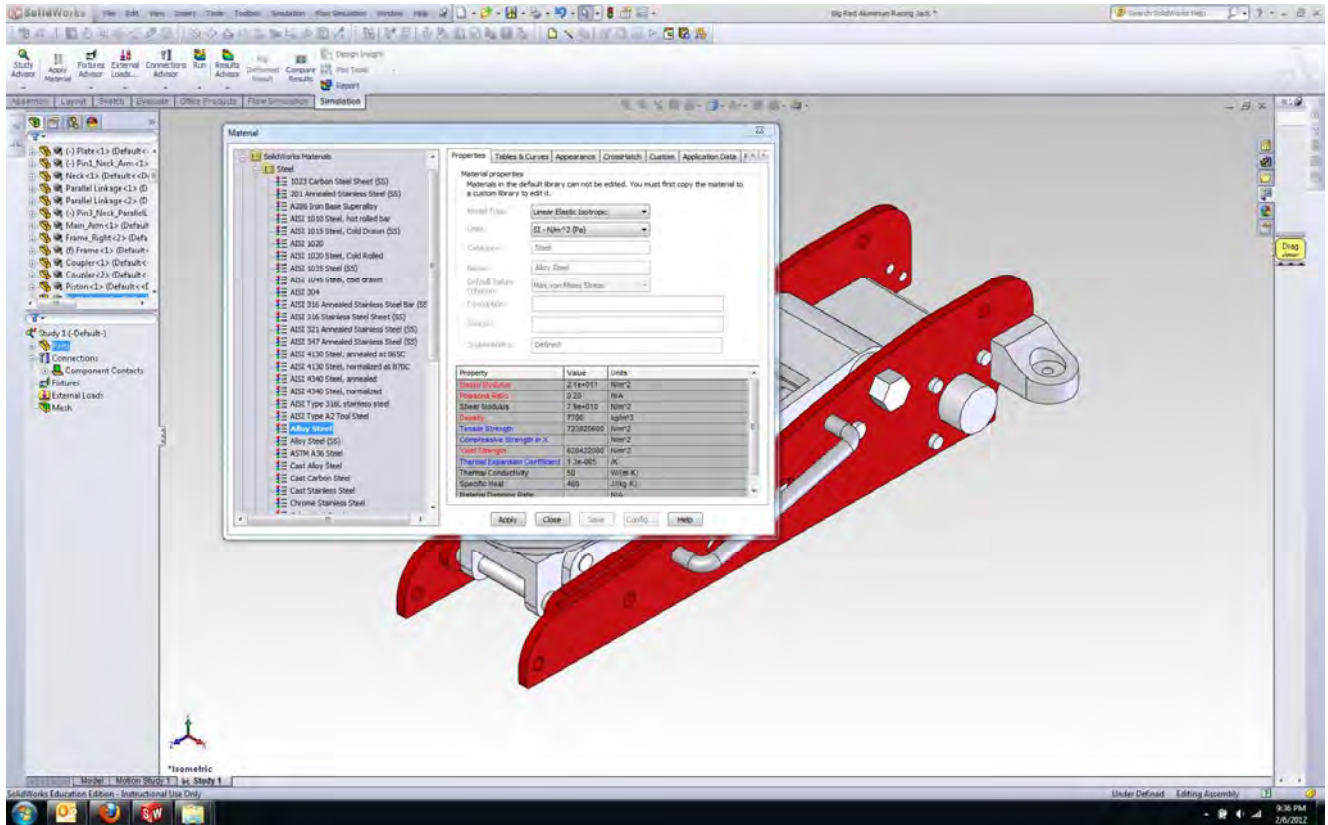

13) The material window pops up. From the material list click the + sign next to **Aluminum Alloys**.

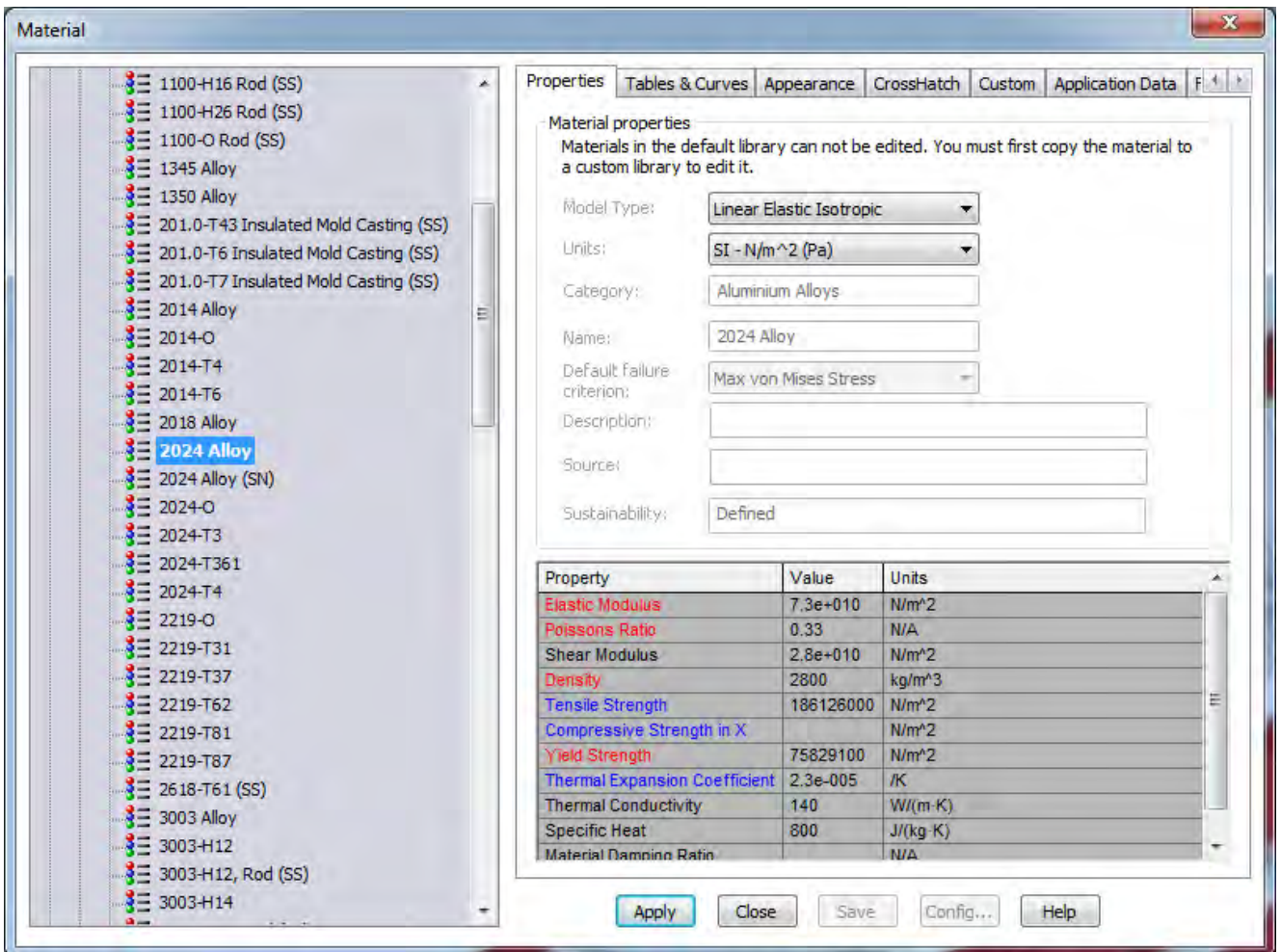



14) Under **Aluminium Alloys**, select **2024 Alloy**. Click Apply, then Close.

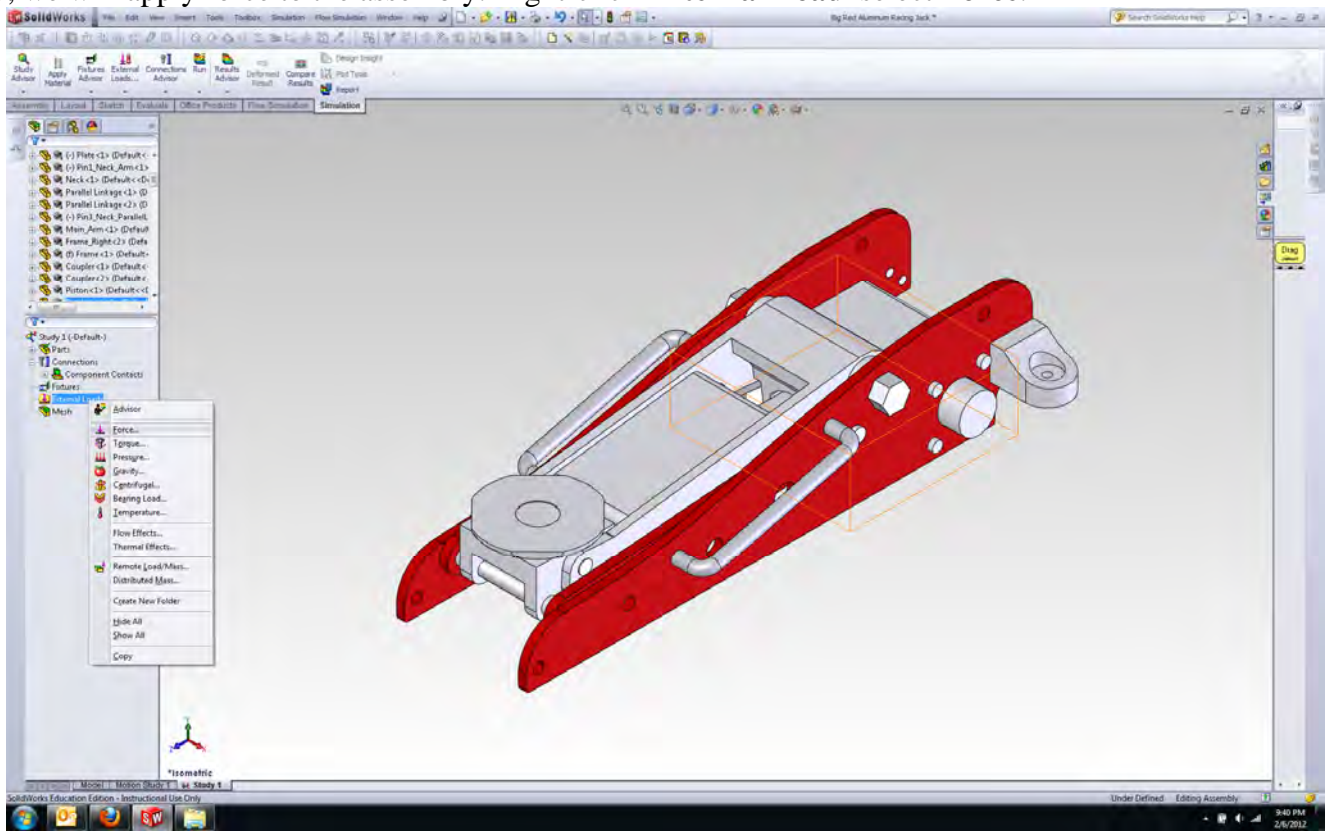

15) Now, we will apply force to the assembly. Right-click **External Load** select **Force**.

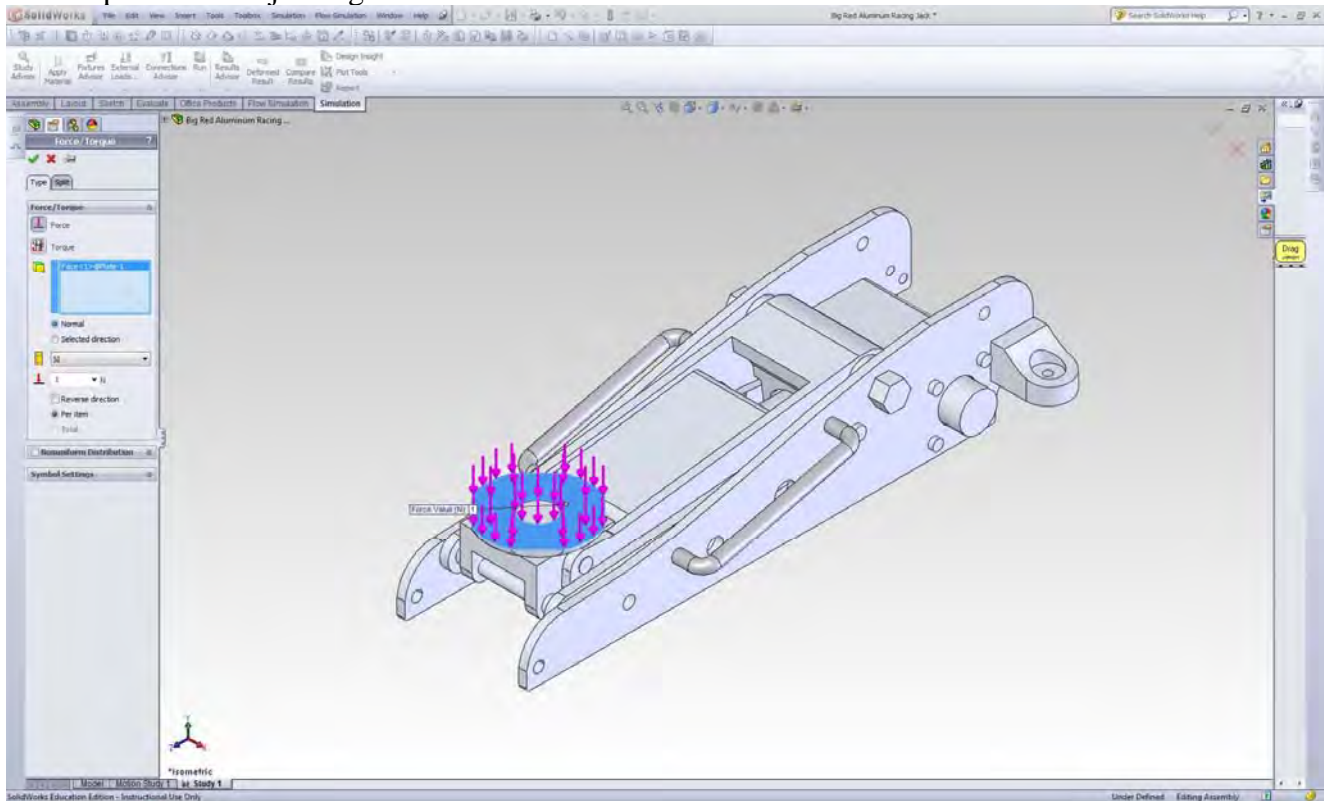

16) Select the top face of the jacking surface





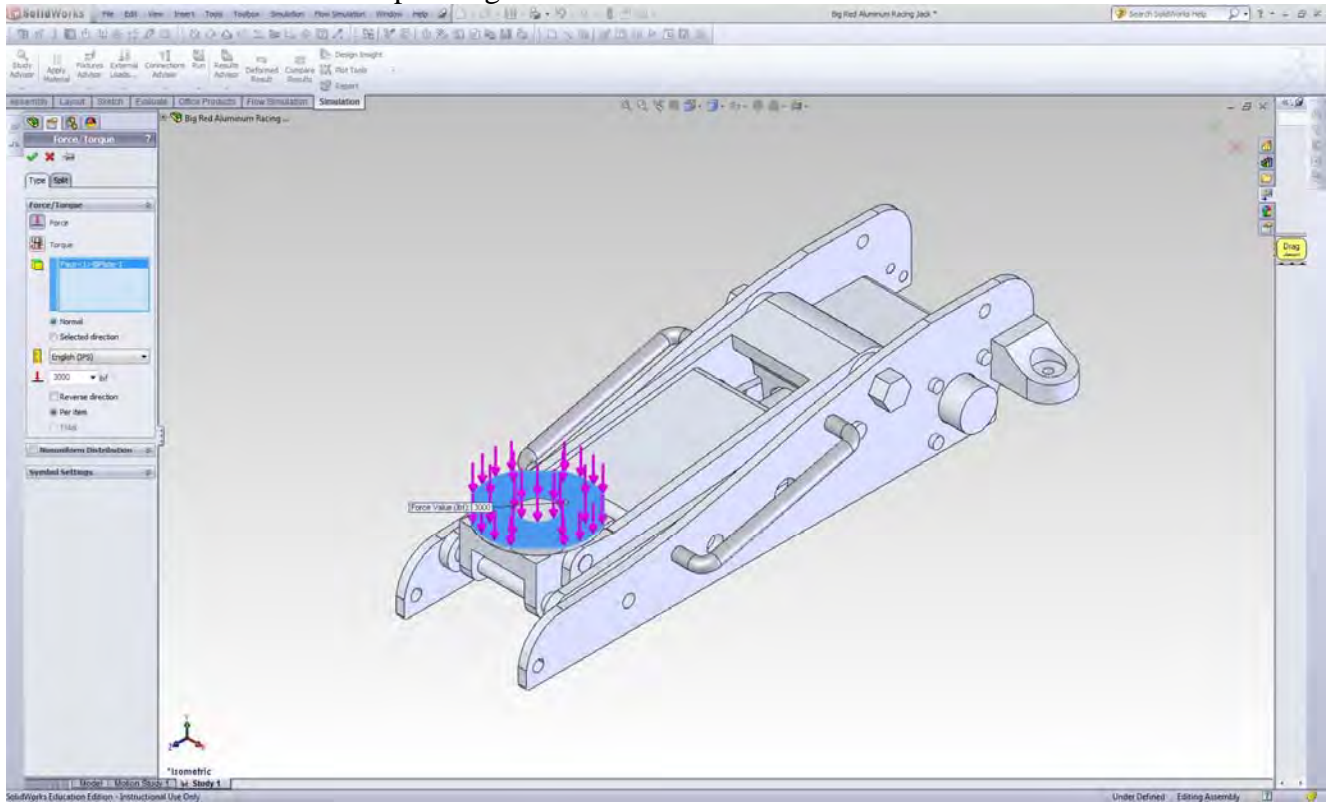

- 17) Change the  **Units** to English (IPS). Under **Force**, select  **normal to direction** and set **3000** as the magnitude of force. Check that force is pointing downward.

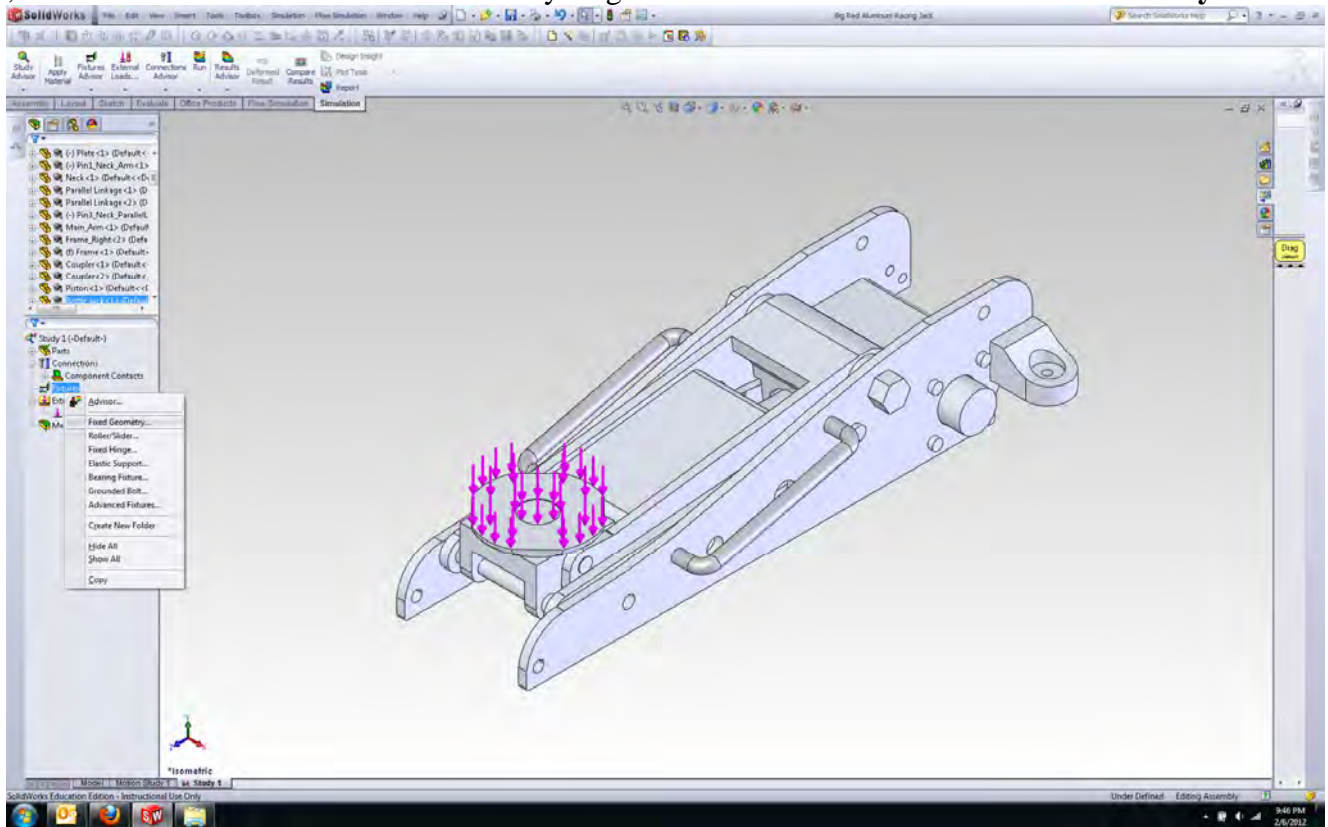

- 18) Now, we will define constraints to the assembly. Right-click **Fixtures** and select **Fixed Geometry**



- 19) For  **Faces, Edges, Vertices for Constraint**, select two upper half of the cylinder where the shaft for the front wheel is mounted. Refer to the picture below.

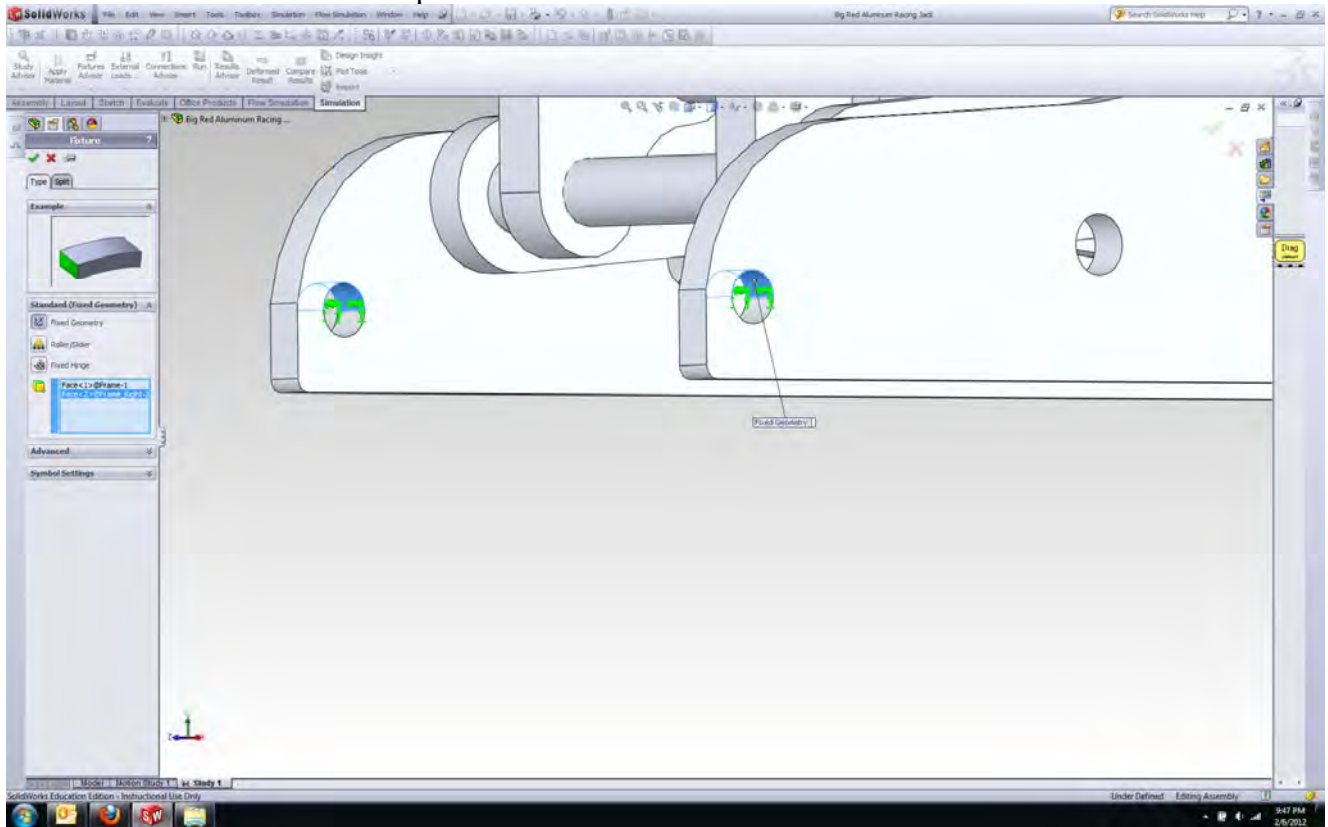

- 20) Now, we will define the second restraint to the assembly. Right-click Fixtures and select **Fixed Geometry**. (see step 18)

- 21) Under the rear wheel mounts, click on the two circular faces as shown in the picture for the  **Faces, Edges, Vertices for Restraint**. These two faces are in contact with the bearings from the rear wheels. Therefore, they are restrained.

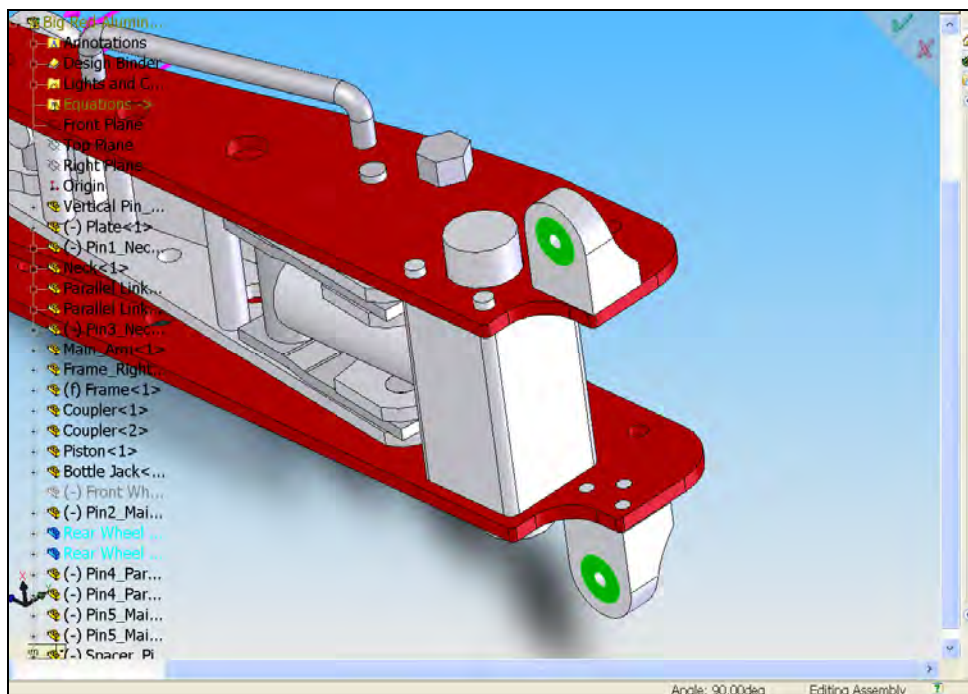



22) On the part lists, right-click **Bottle Jack** and select  **Hide**.

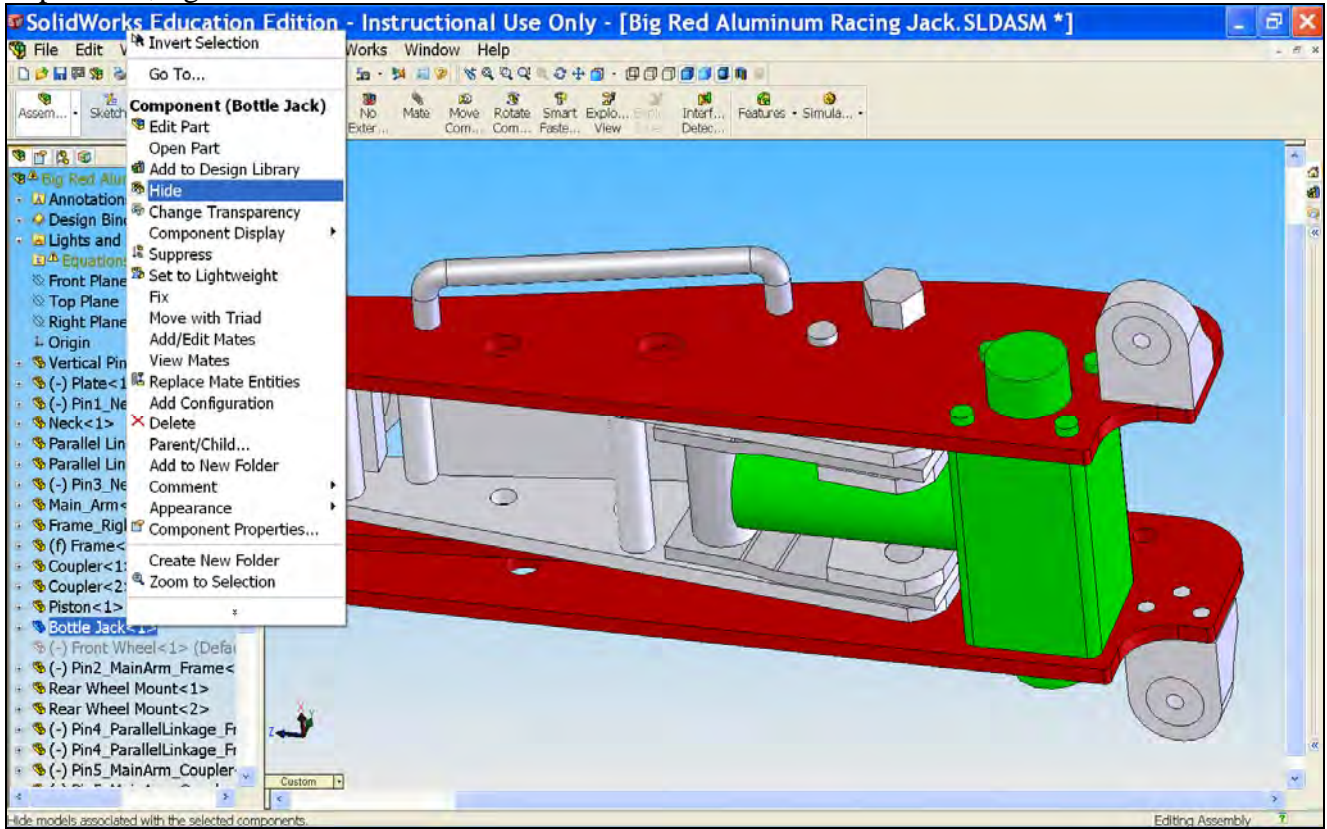

23) The Bottle Jack is now hidden and we can go back to the SolidWorks Study.

24) Right-click **Fixtures** and select **Advanced Fixtures**

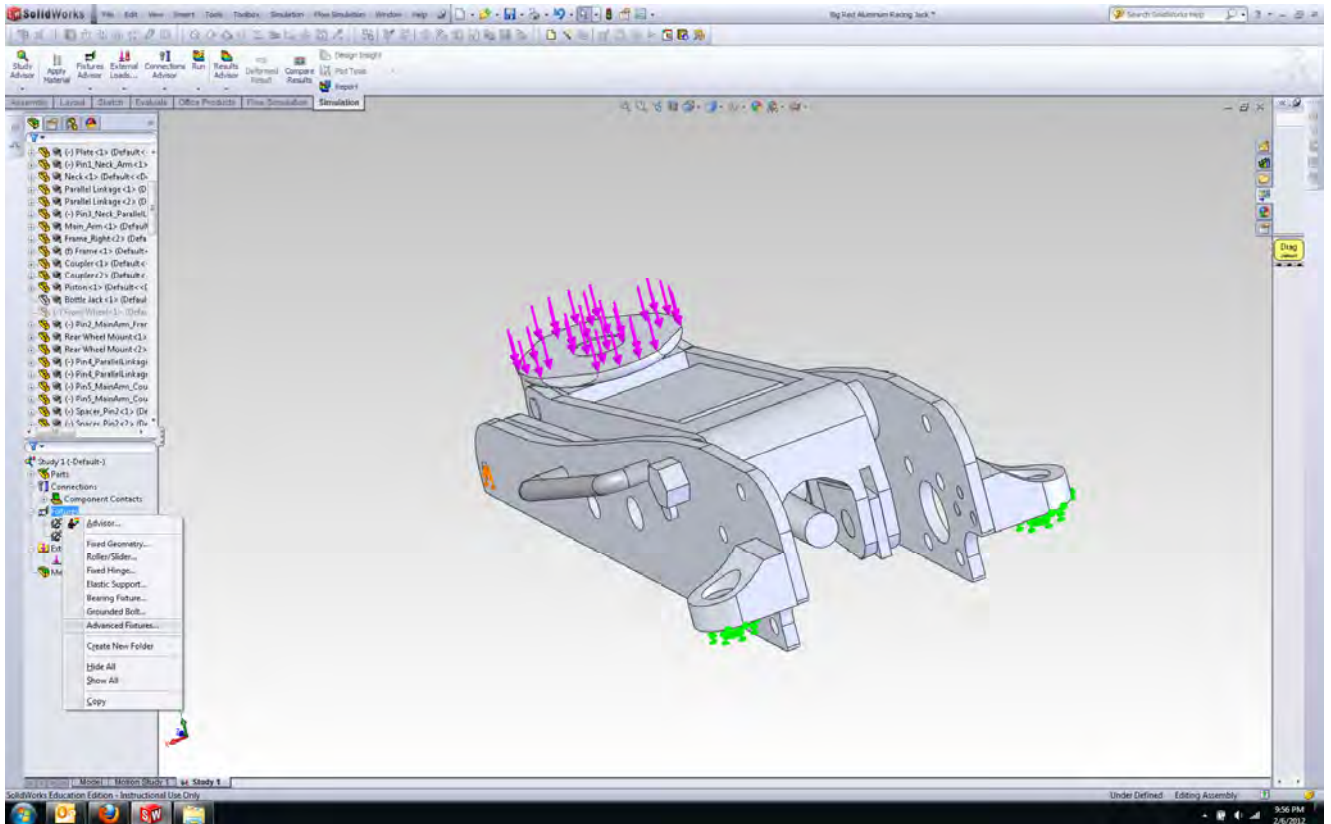

25) For  **Faces, Edges, Vertices for Restraint**, click on the end face of the piston as shown in the picture.

26) Select the Front Plane from the assembly tree as the  **direction for restraint**. (next to the pink box)

27) Under translation, click  **Normal to plane** and set the value to 0.

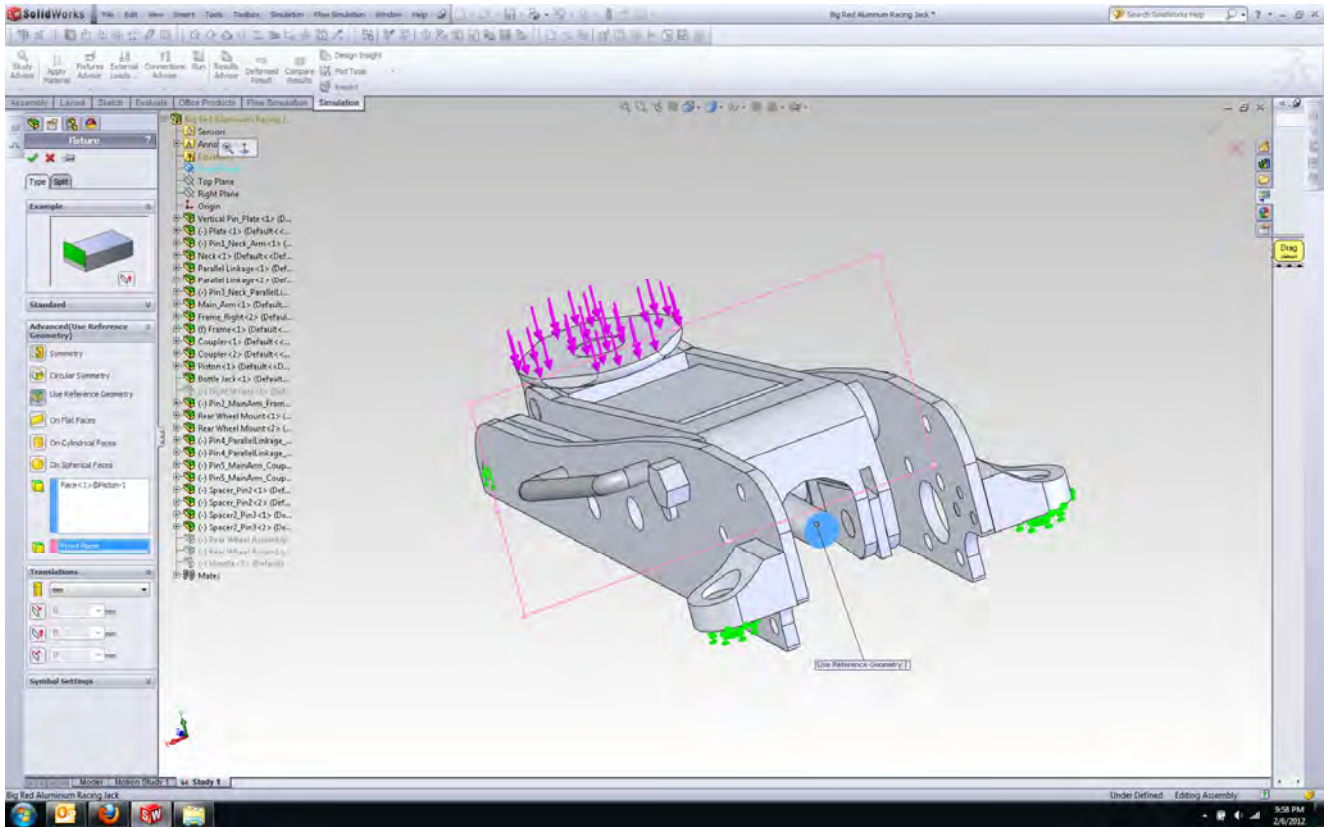



28) We have completed applying restraints to the assembly. Now, we can show the Bottle Jack back to the assembly.

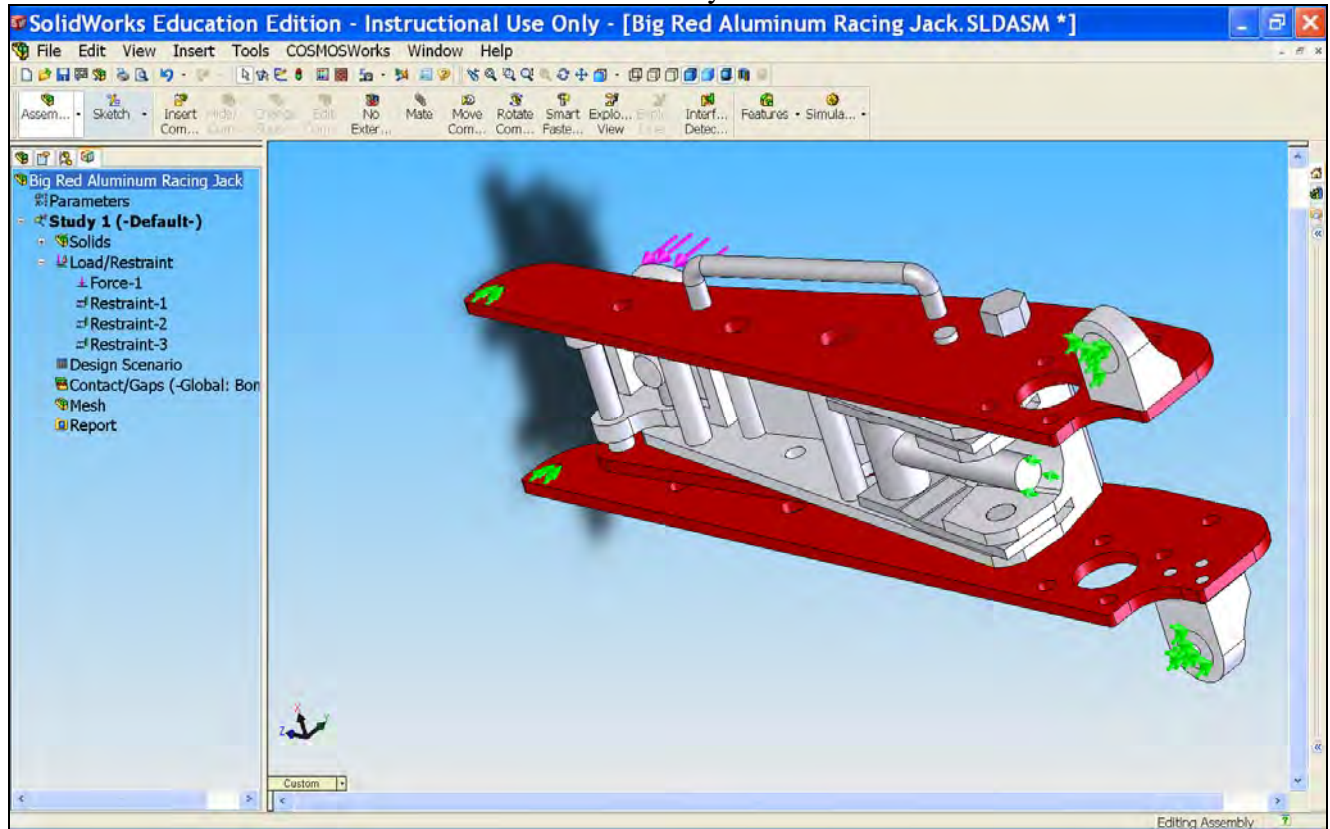

29) Go to **FeatureManager** design tree, right-click **Bottle Jack** and select  **Show**.

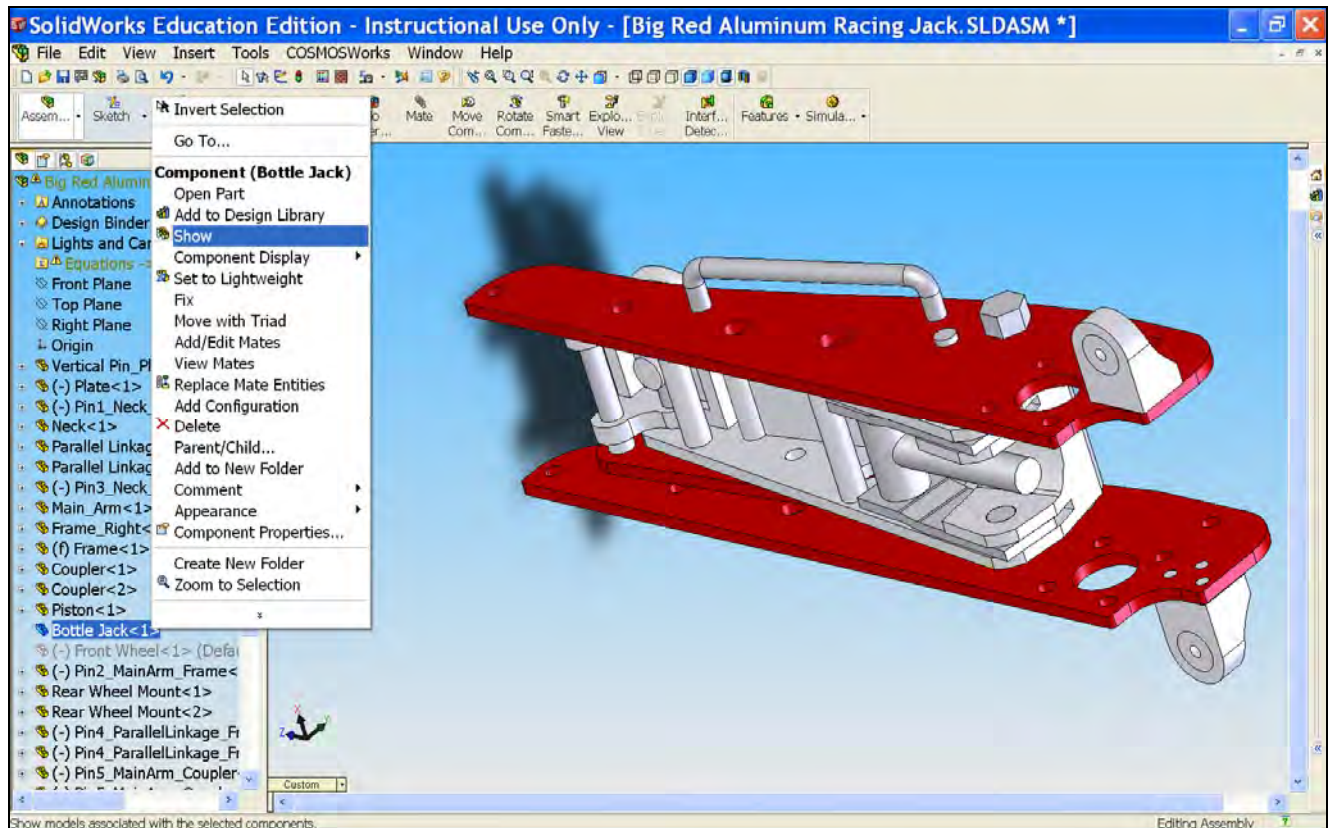

30) The Bottle Jack is now shown back to the assembly.

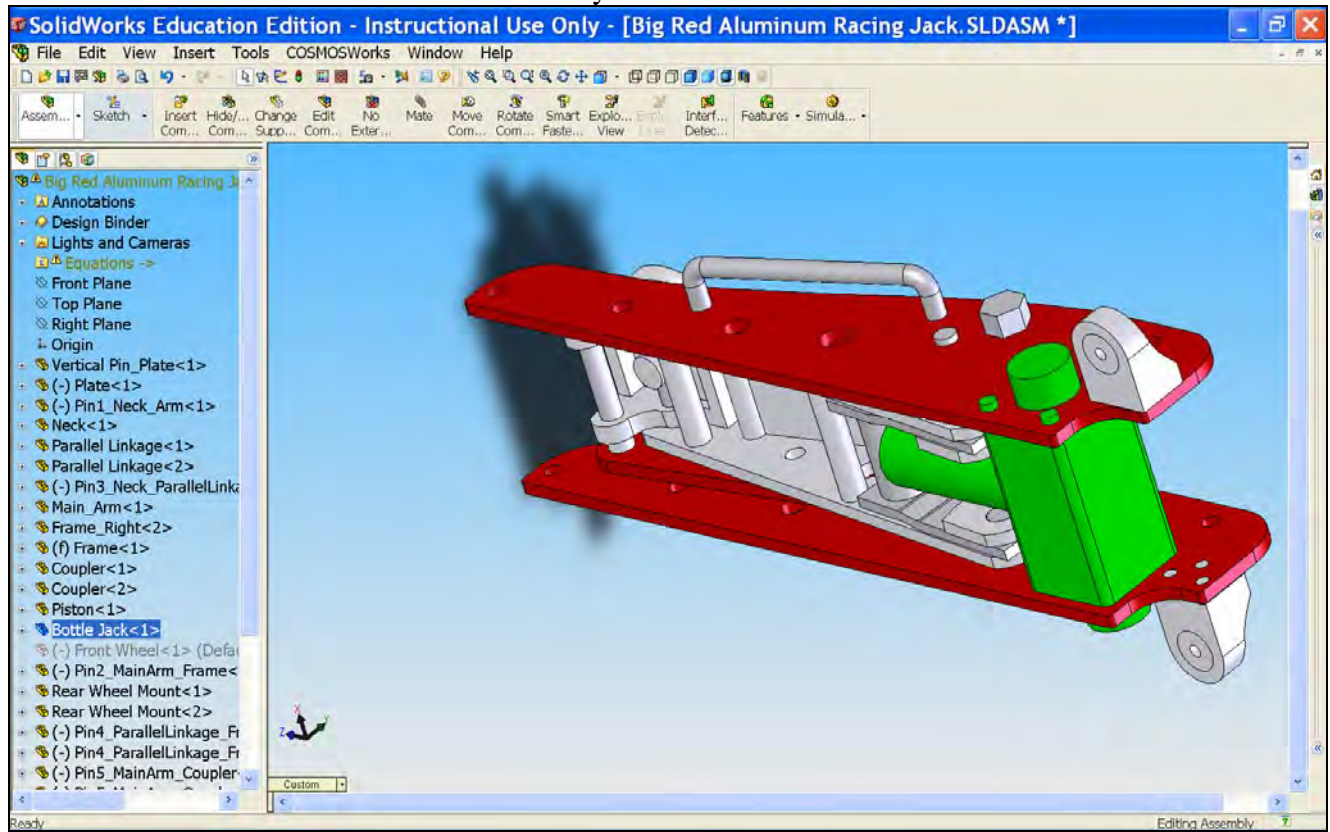

31) Now, we will define a contact type to the assembly. Expand the tree item labeled **Connections** then **Component Contacts** and right click on **Global Contact** and click Edit Definition

32) Select **Bonded**. Click OK.

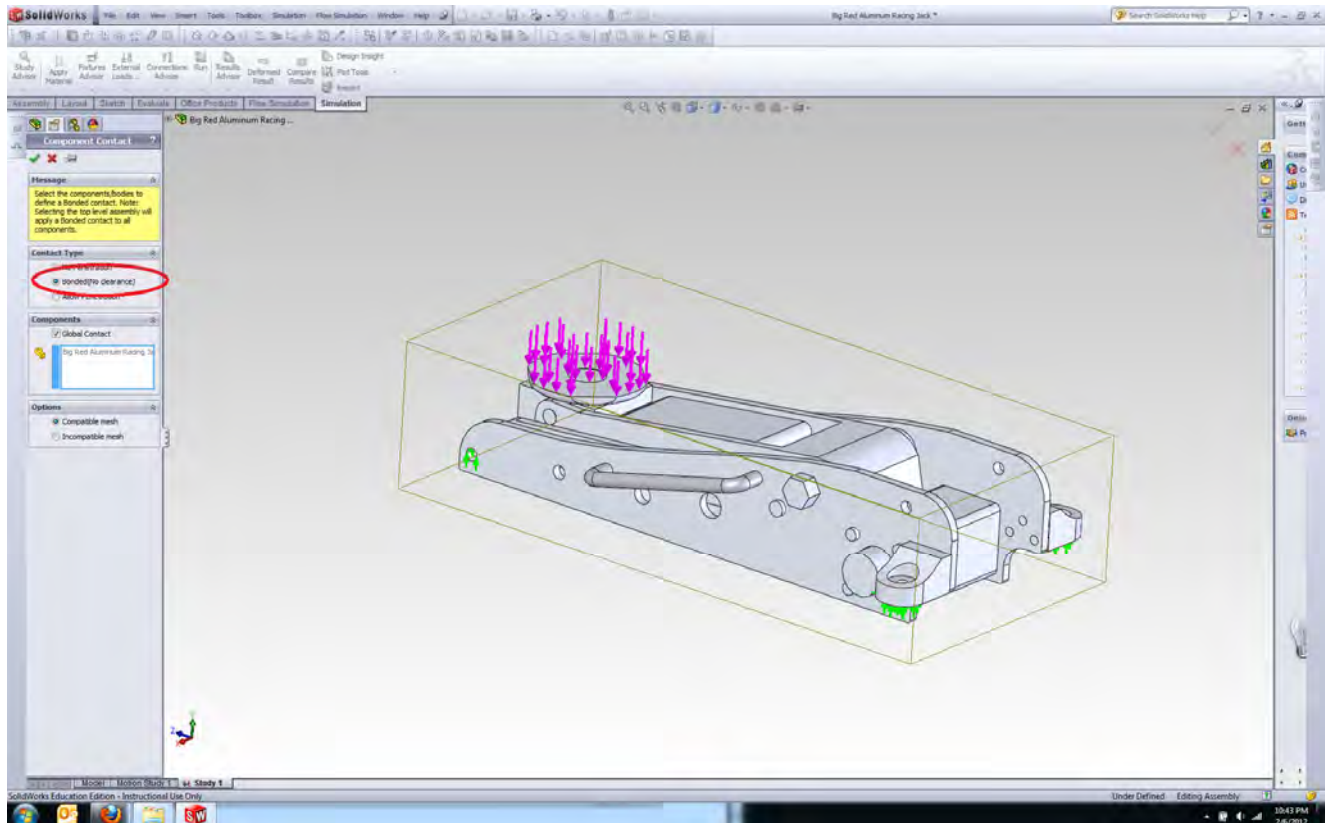



33) Now, it is time to create mesh. Right-click **Mesh** and select **Create Mesh**.

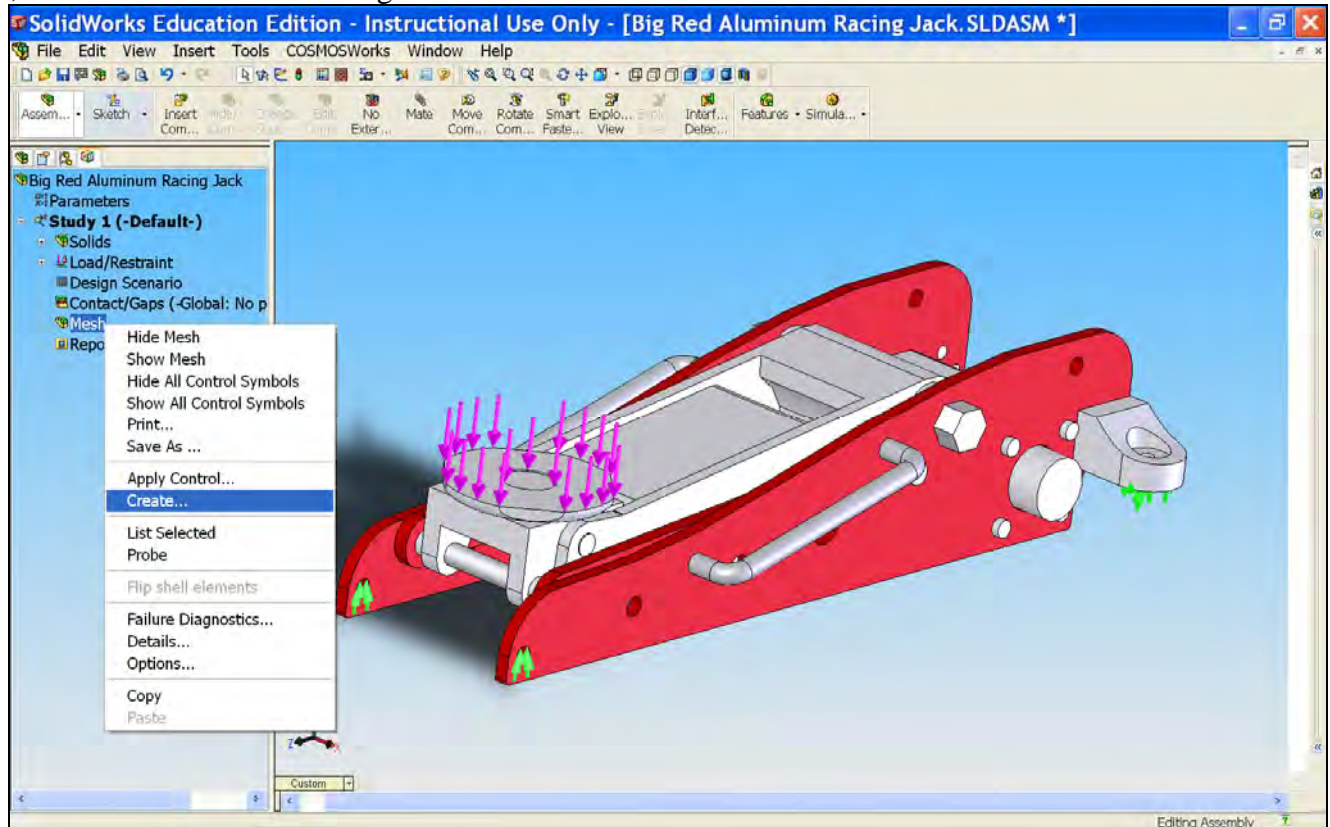

34) The Mesh window appears on the left. Click **OK** to accept the default values for meshing.

35) The program is now creating the mesh for the floor jack assembly.

36) Meshing is now complete and it is time to run the Solidworks analysis. Right-click **Study 1** and select **Properties**.

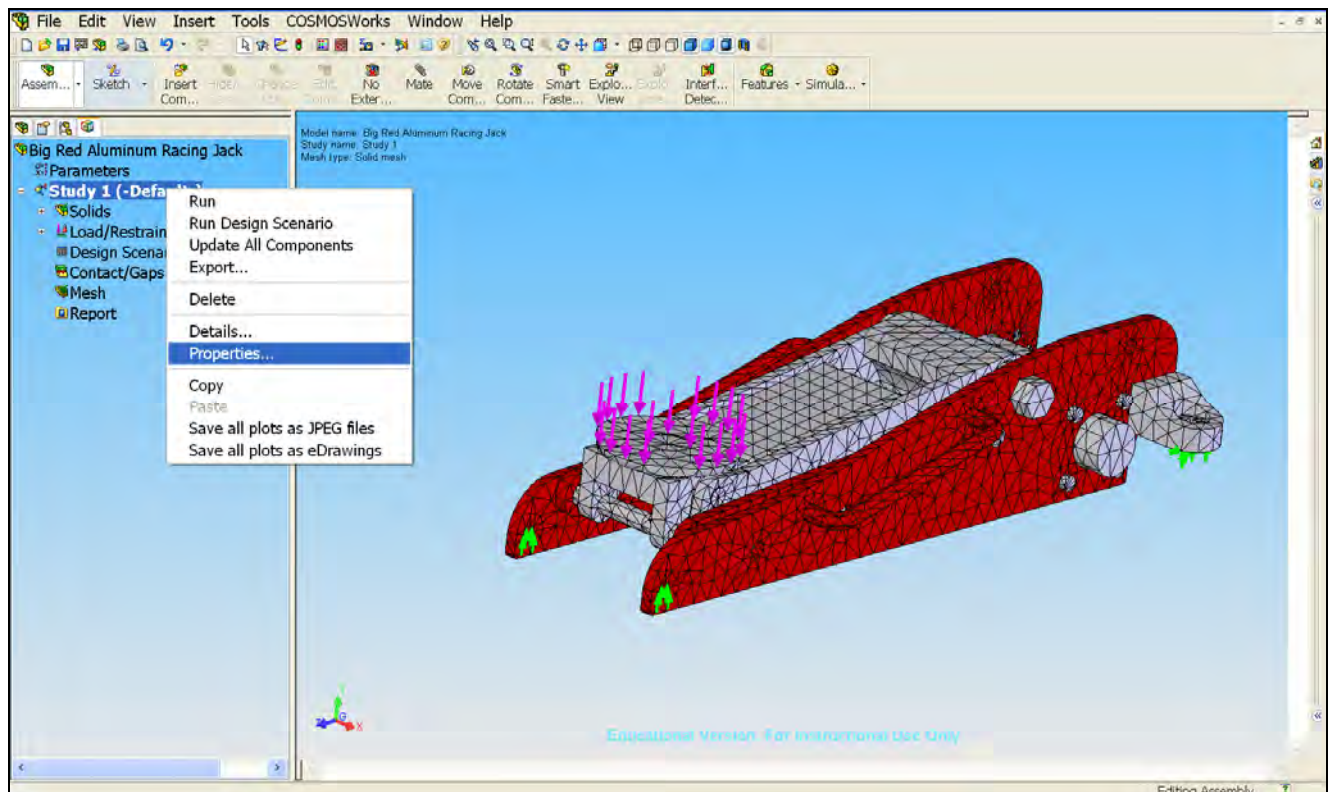

37) Select **Direct sparse** as a solver and click **OK**. Using Direct sparse as a solver will minimize the time to run the analysis and it also gives more accurate results. However, the downside of using this solver is that it uses too much RAM space which will cause the computer to run slow.

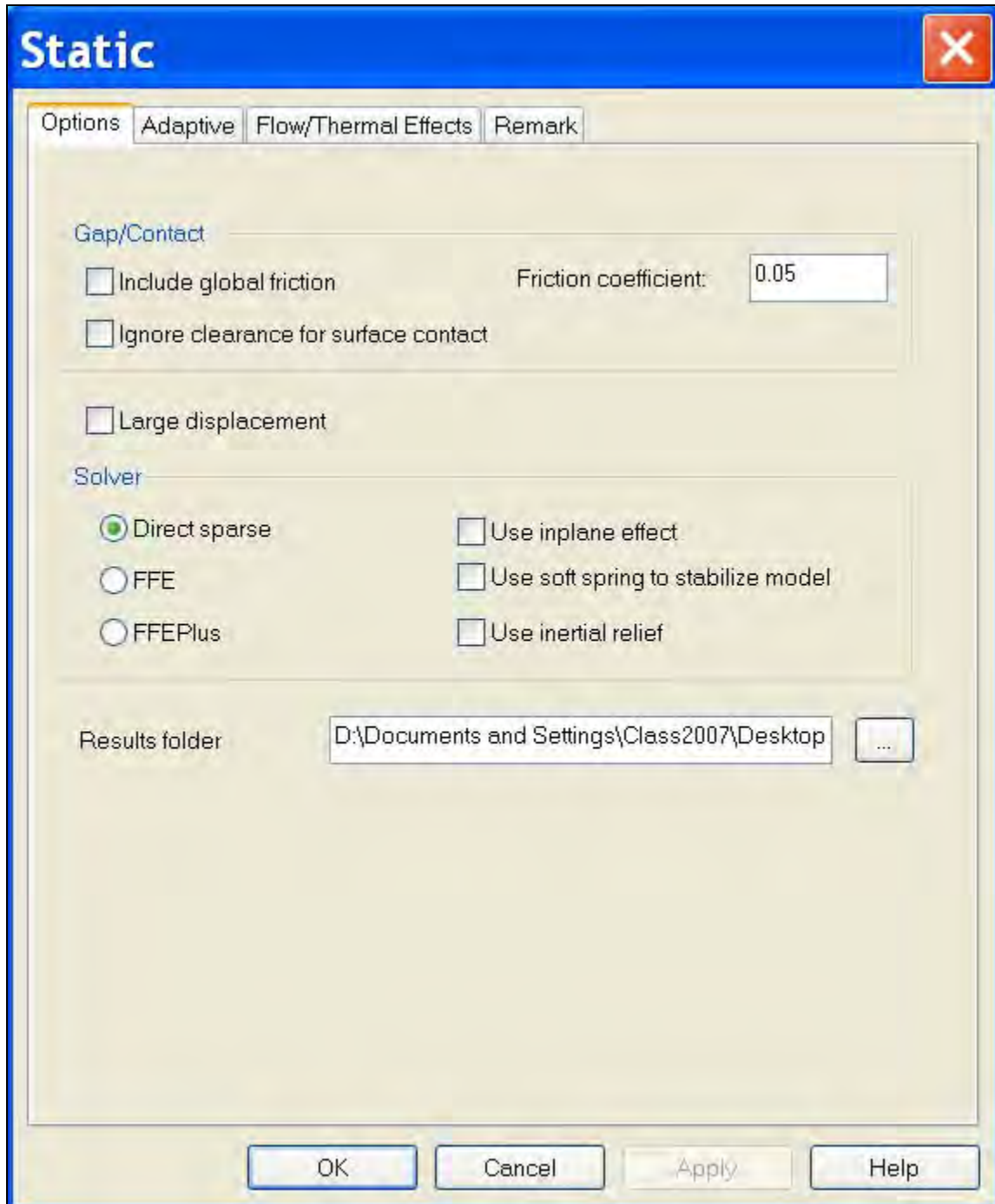



38) Now Click **Run** at the top of the screen.

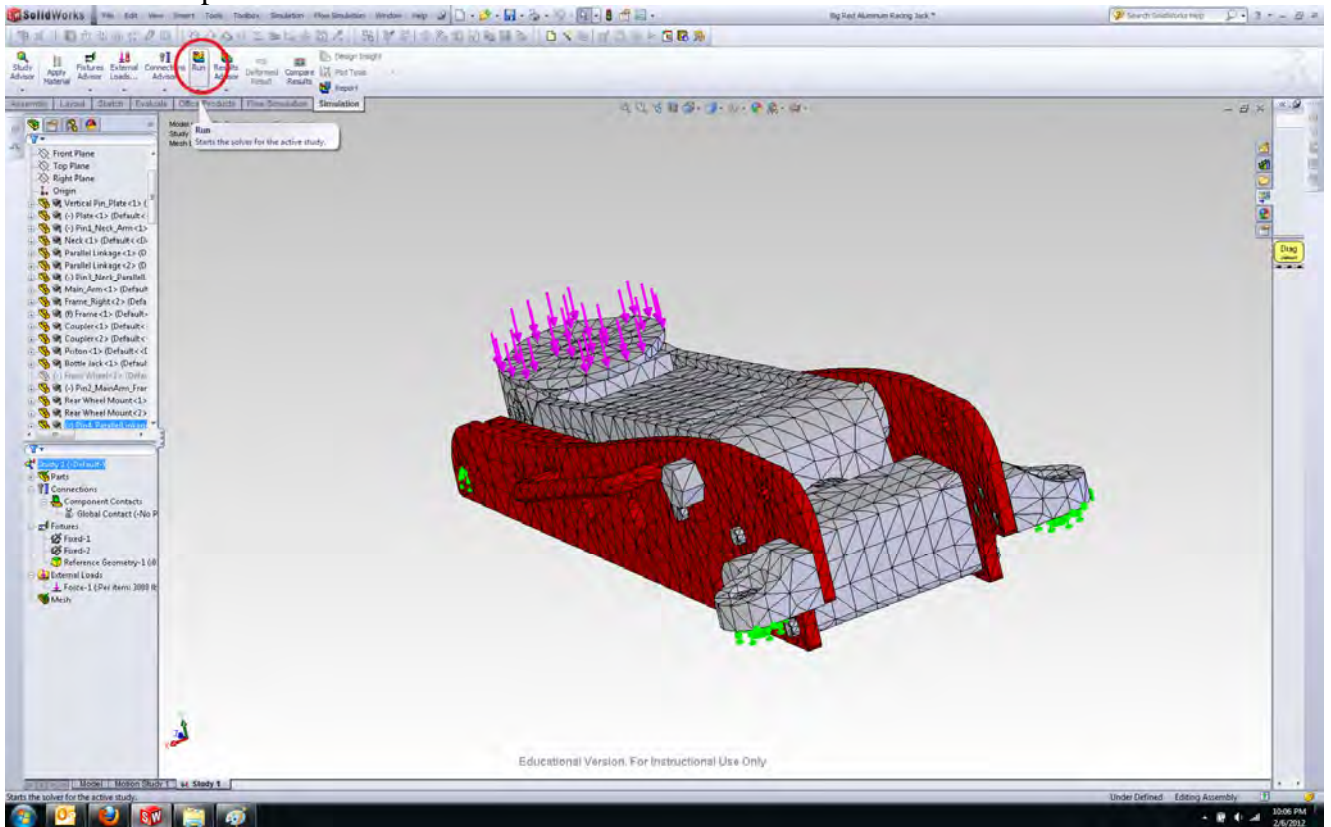

39) SolidWorks is now running the FEA analysis.

40) The analysis is now complete.

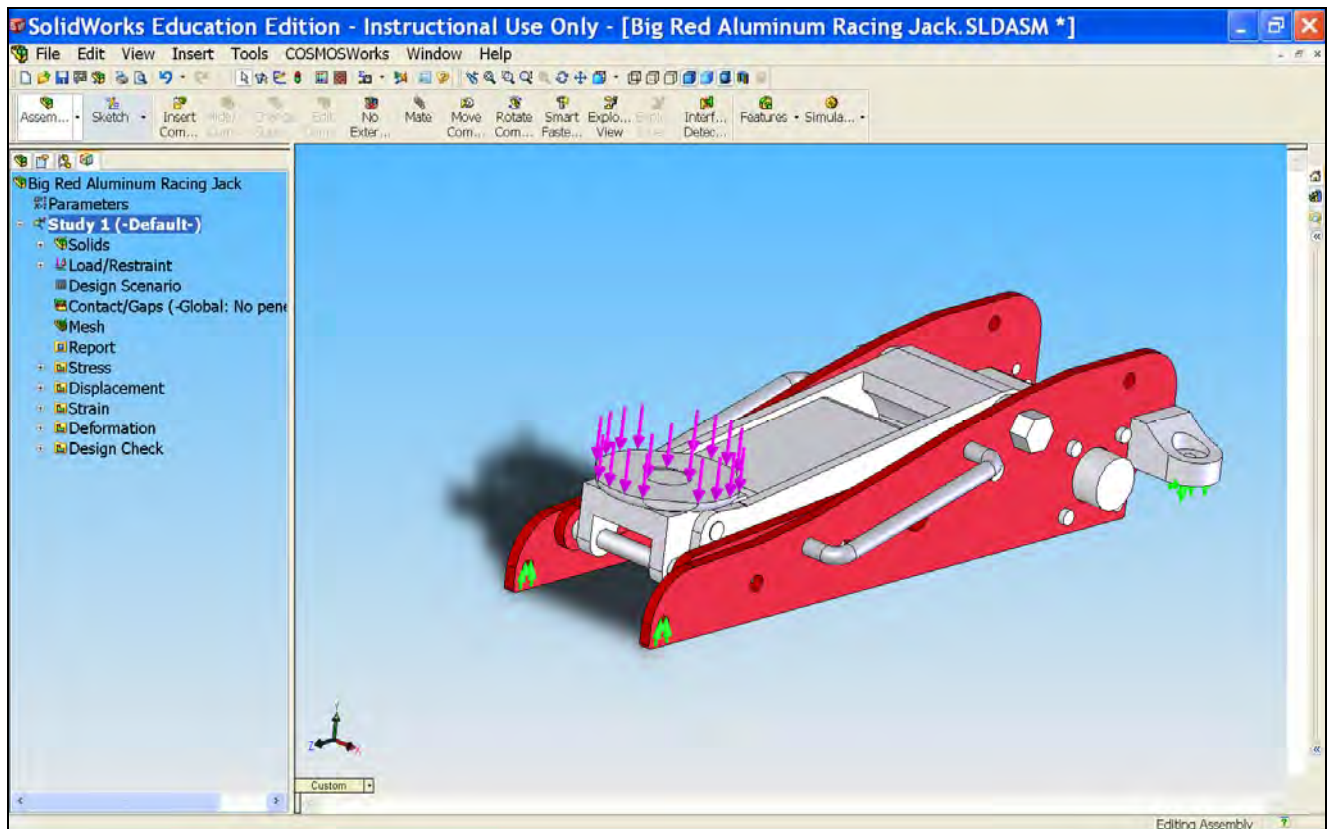

41) The von Mises stress plot, is shown by default

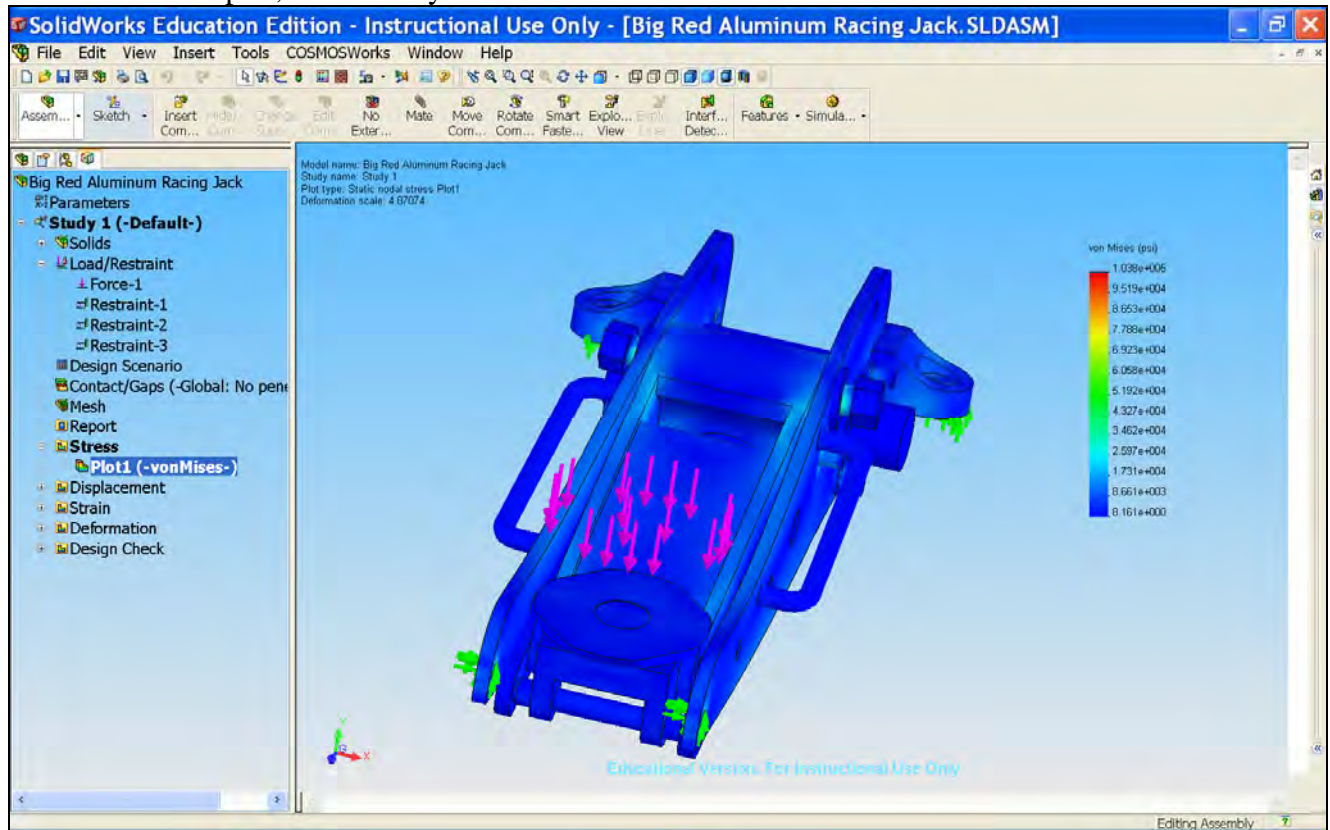

42) To better understand how the parts deform under loading, we can use an animation function to show us the stress and deformation of the assembly over a period of time. Go to **Simulation** menu on top, then go to **Result Tools** and select **Animate**.

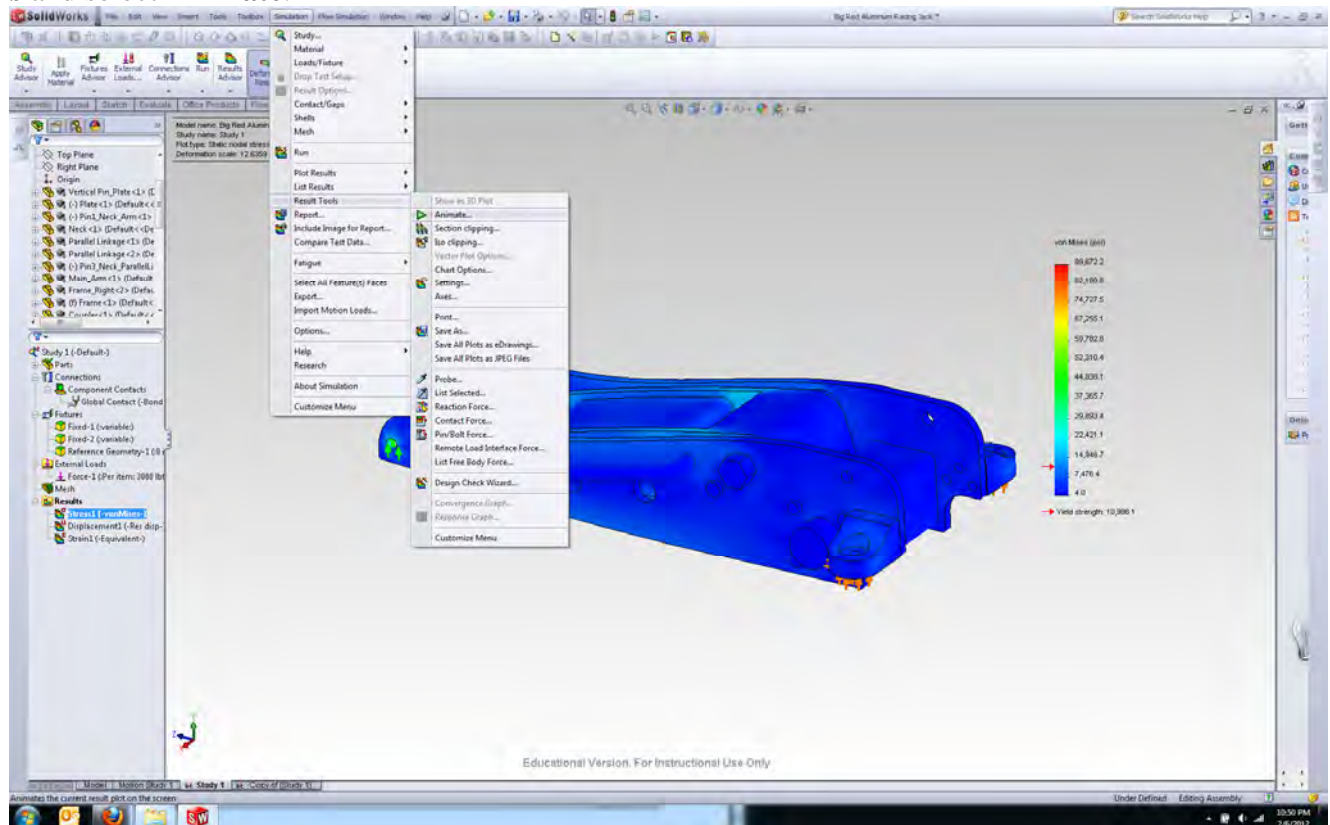



43) Hit the  play button to run the animation.

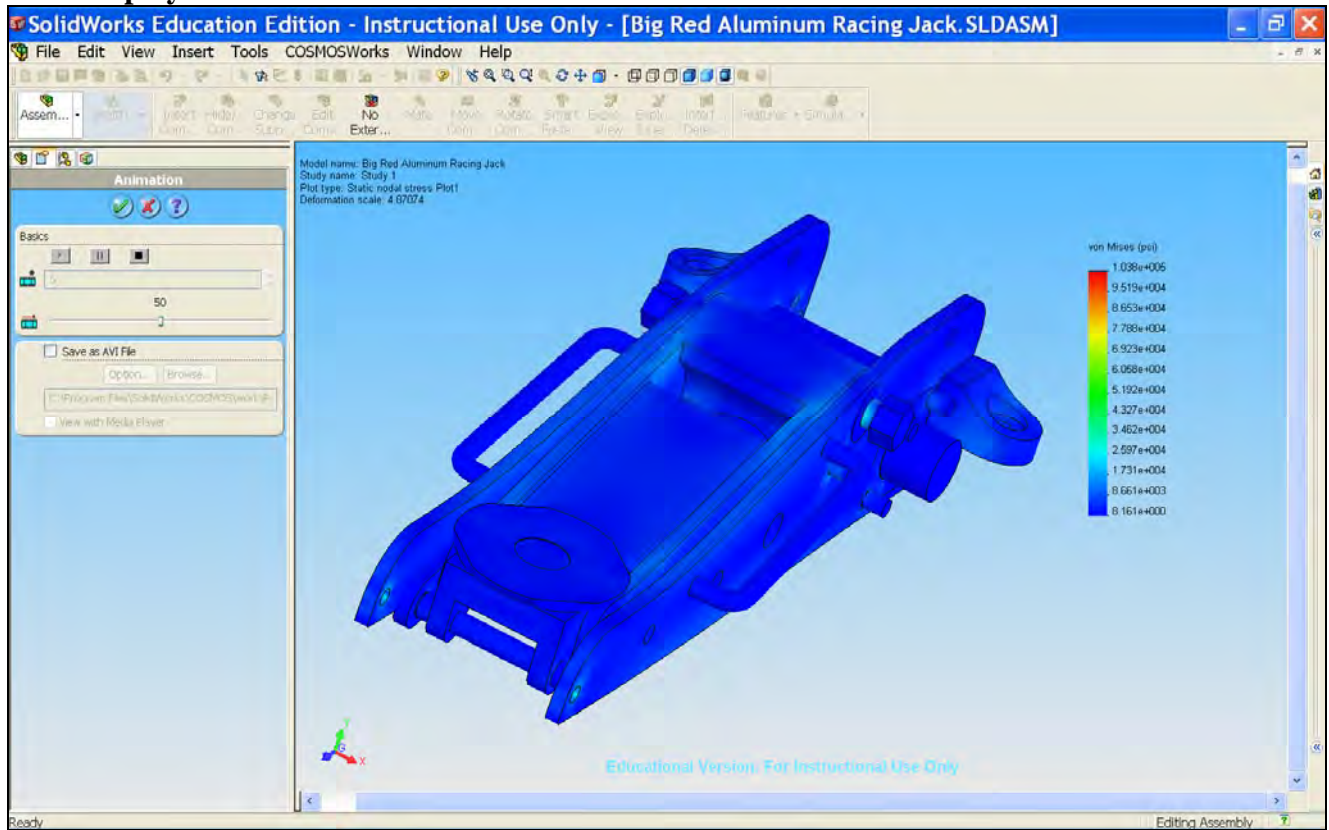

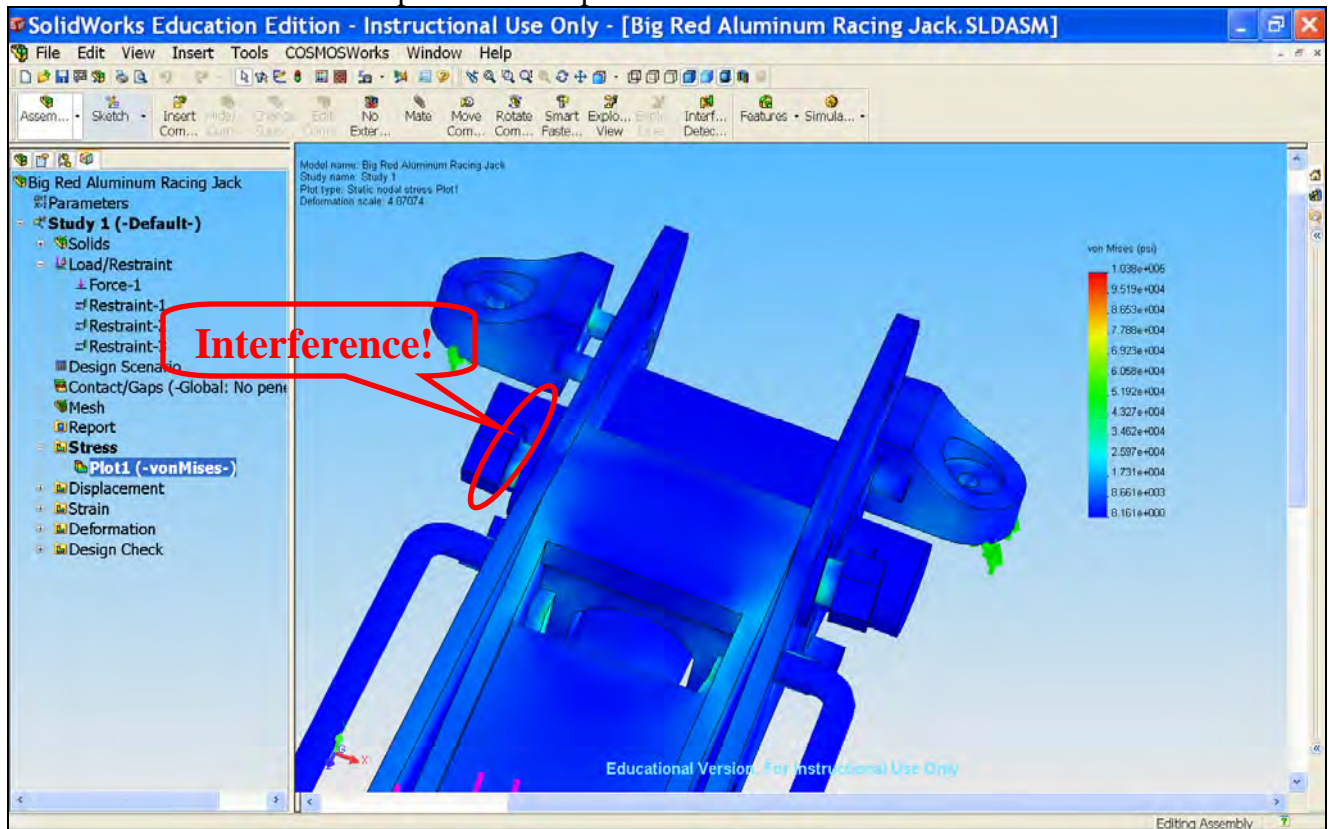

44) Click OK to end animation

45) Note that some components actually intersect each other. This is not desirable because in real life, parts interference does not occur. Therefore, accurate results will not be obtained if the interference is present. The picture below points out the interferences.

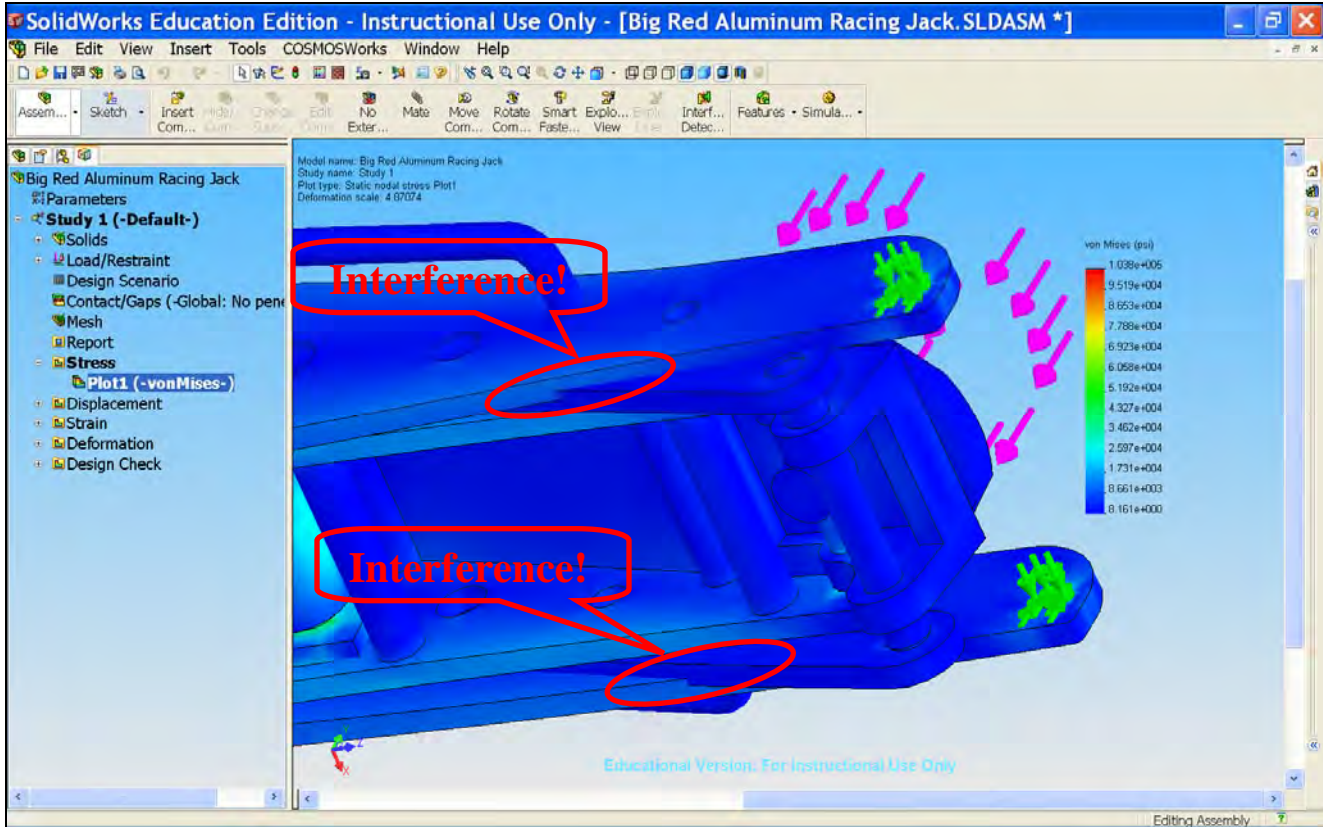

46) Interference can also be seen here.



47) To fix the interference problem, we need to further define the contact or gaps for the assembly. First, put the mouse pointer anywhere on right frame surface and right-click it. Then, select  **Change Transparency**.

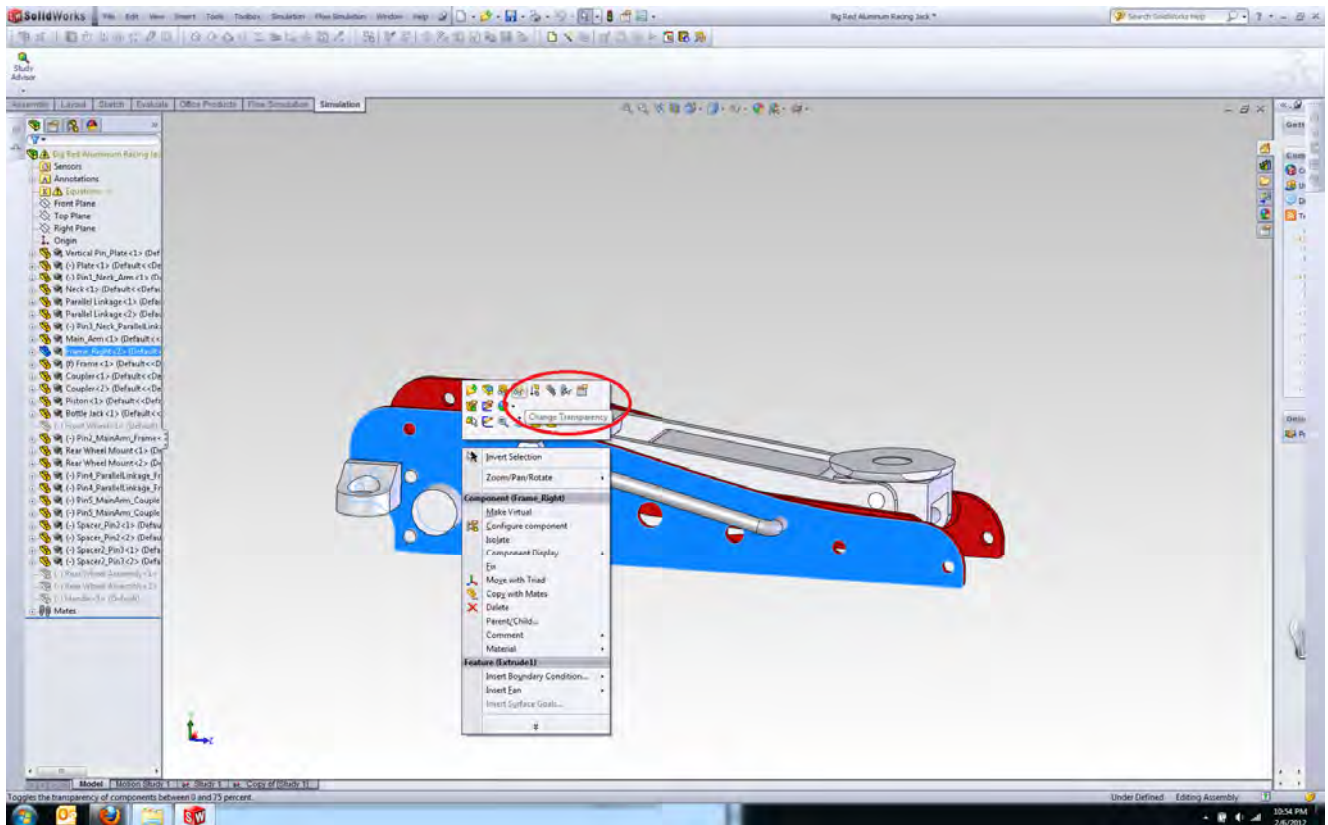



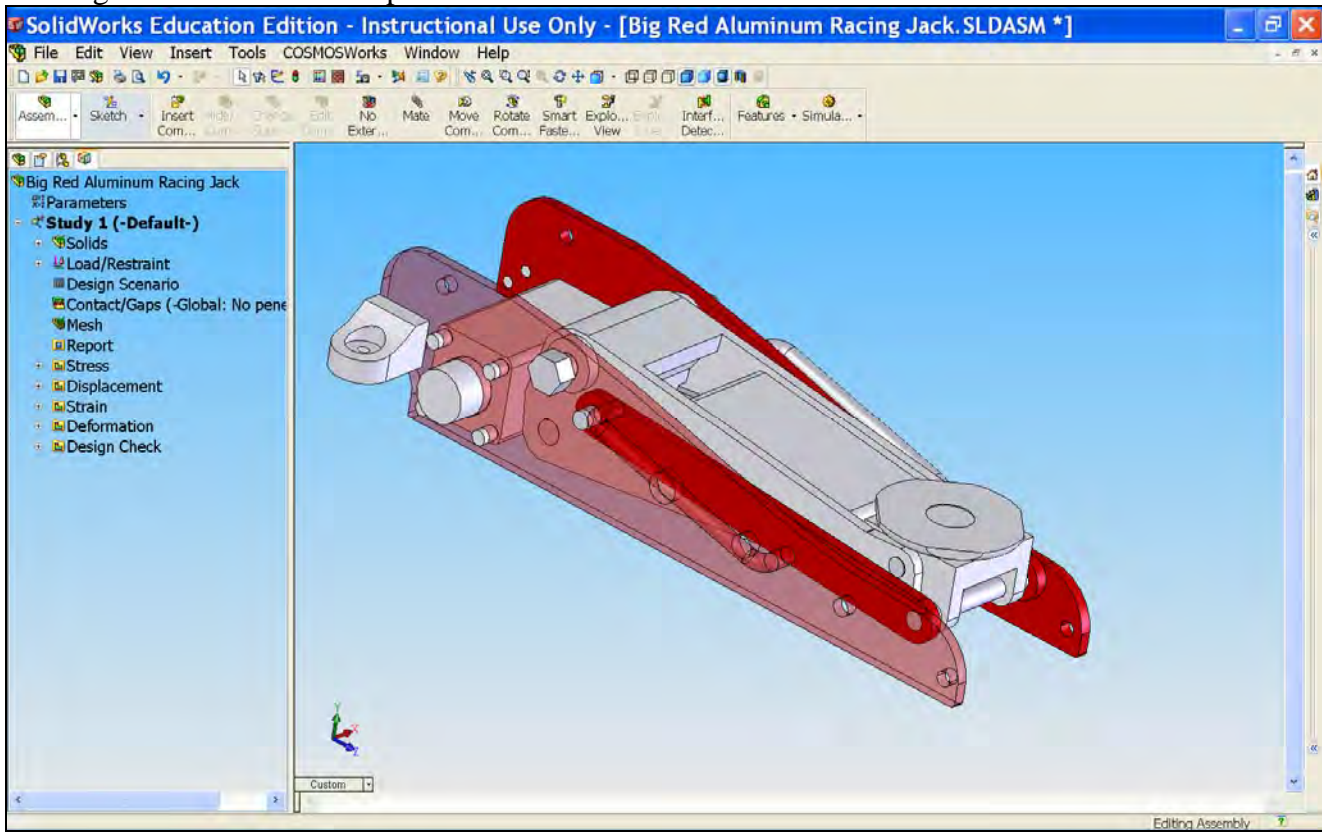

48) The Right Frame is now transparent.

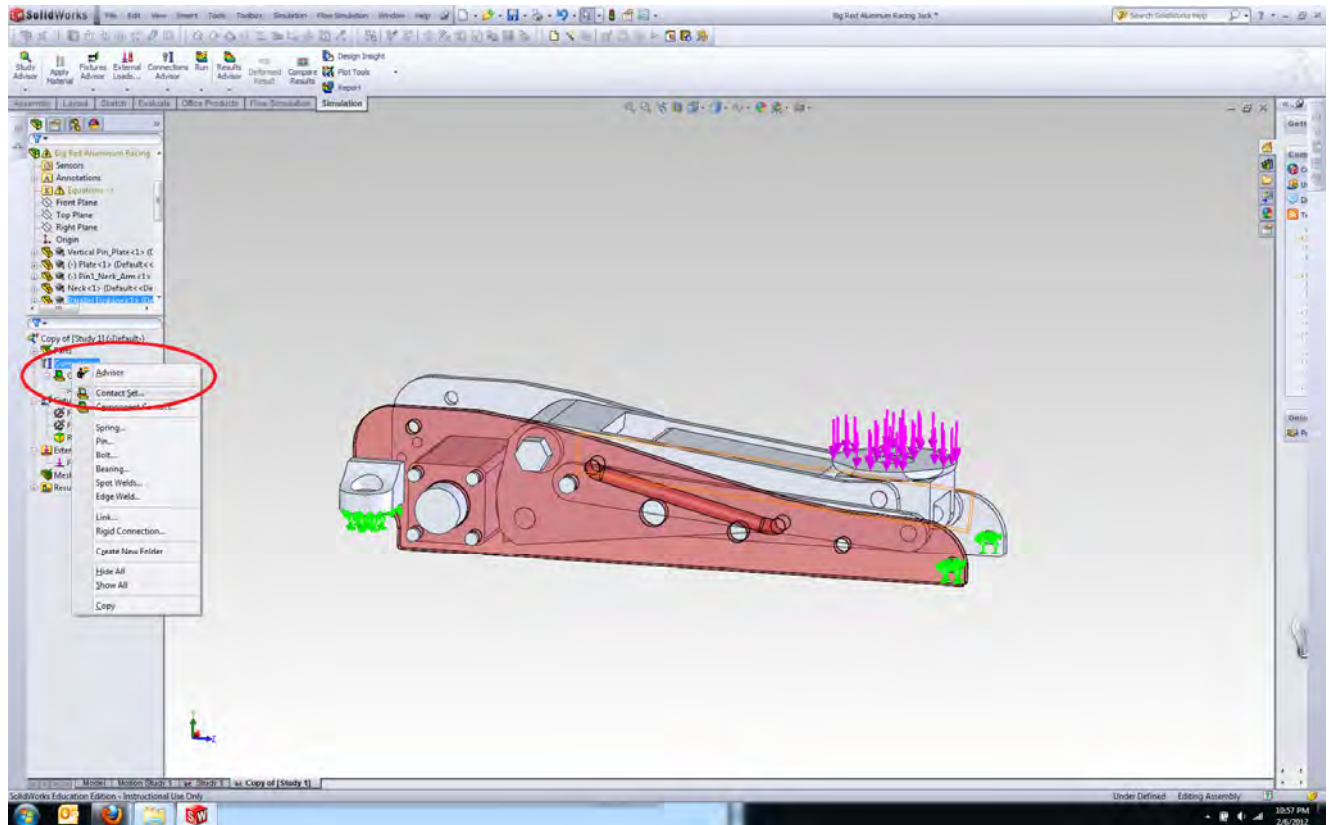

49) Right-click **Connections** and select **Contact Set**.



50) For  **Faces, Edges, Vertices for Source**, select the face of **Parallel Linkage** as shown in picture below.  
(Note: The **Parallel Linkage** surface that you need to select is highlighted in green.)

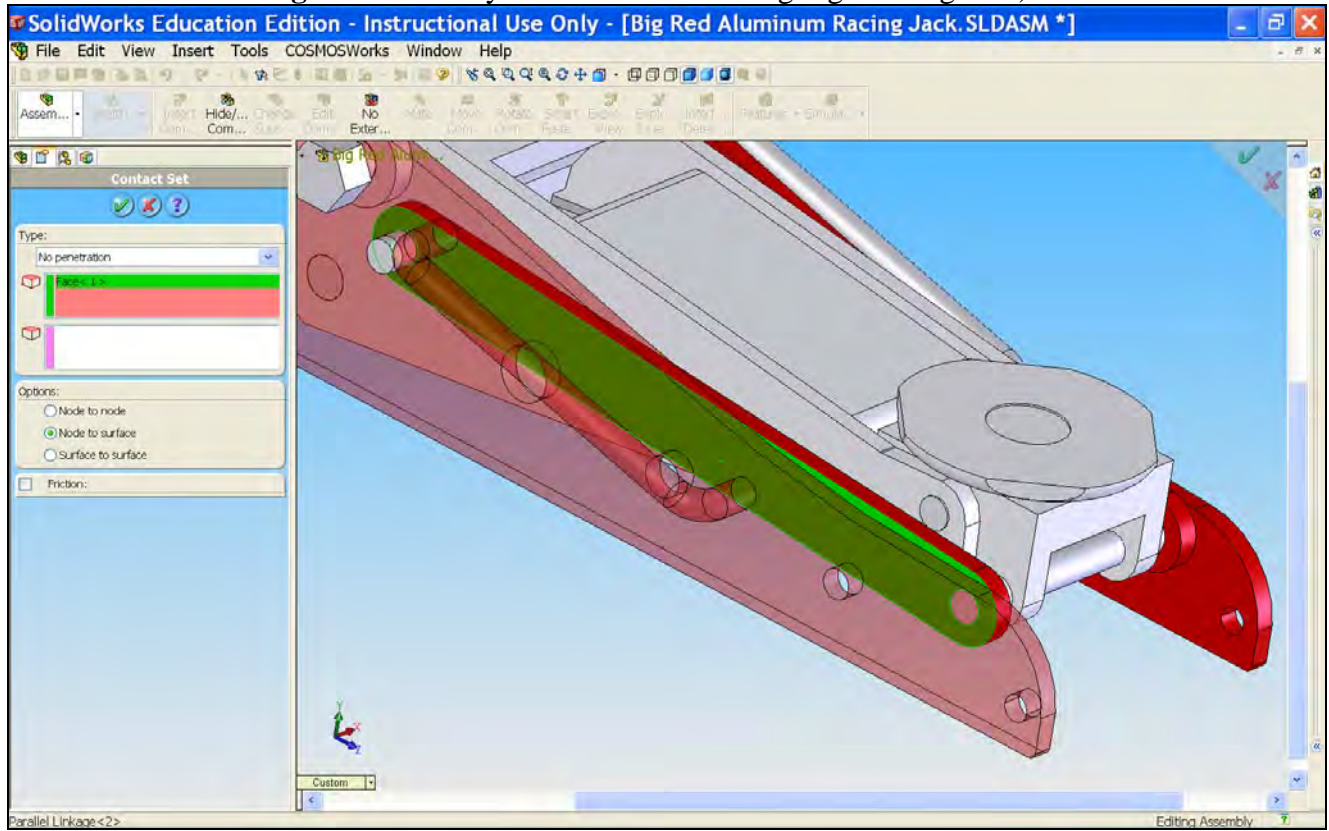



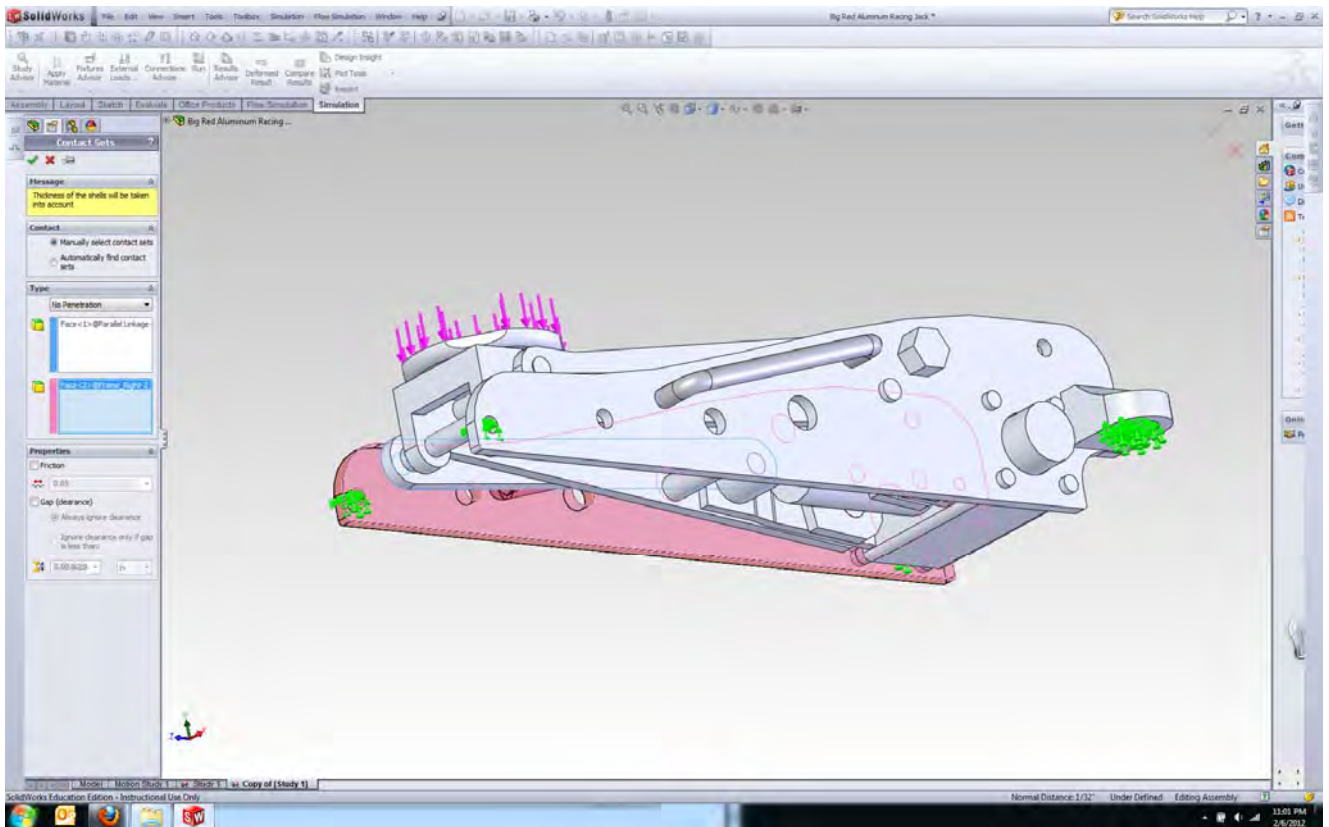
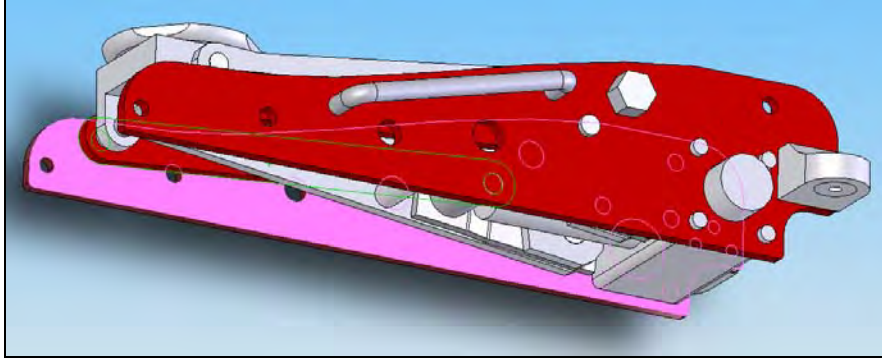

- 51) For  **Faces for Target**, select the surface of the **Right Frame** as shown in the picture below. Under **Type**, select **No Penetration**. Click **OK**. (Note: The **Right Frame** surface that you need to select is highlighted in pink.)

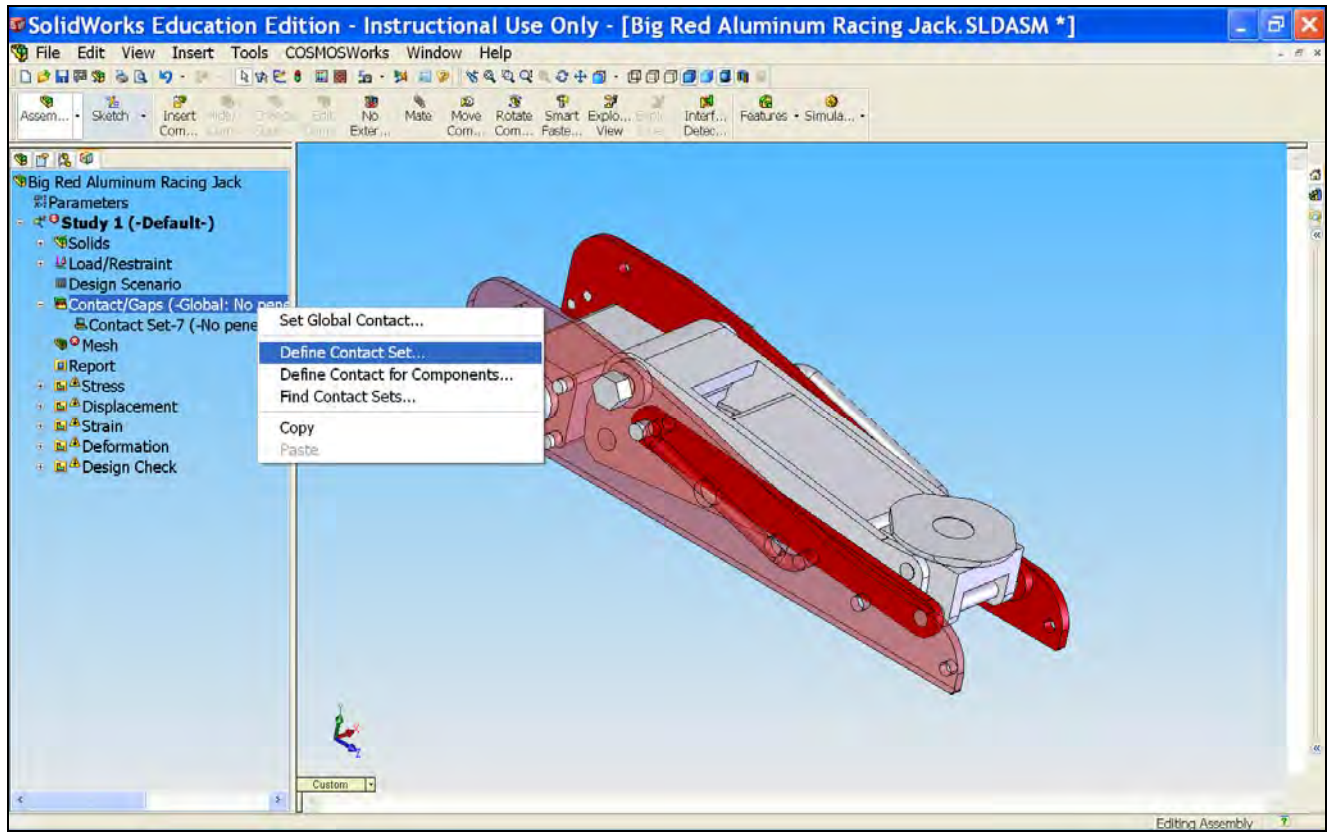

52) Right-click **Connections** and select **Contact Set**.



53) For  **Faces, Edges, Vertices for Source**, select the face of **Spacer Pin2<2>** as shown in picture below.  
(Note: The **Spacer Pin2<2>** surface that you need to select is highlighted in green.)

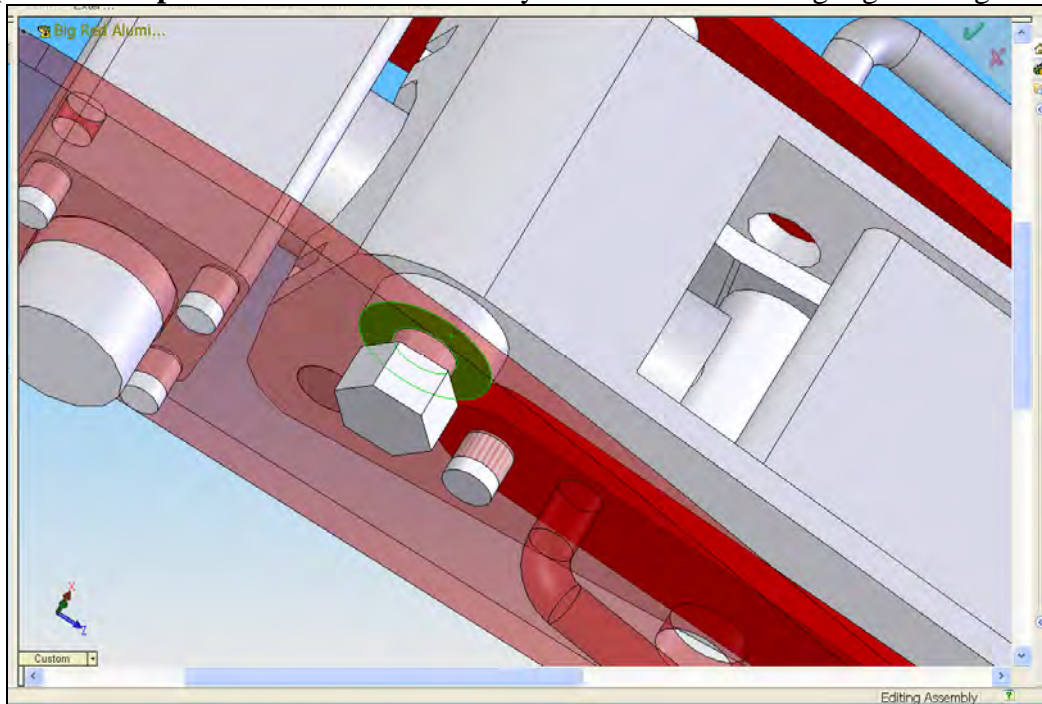





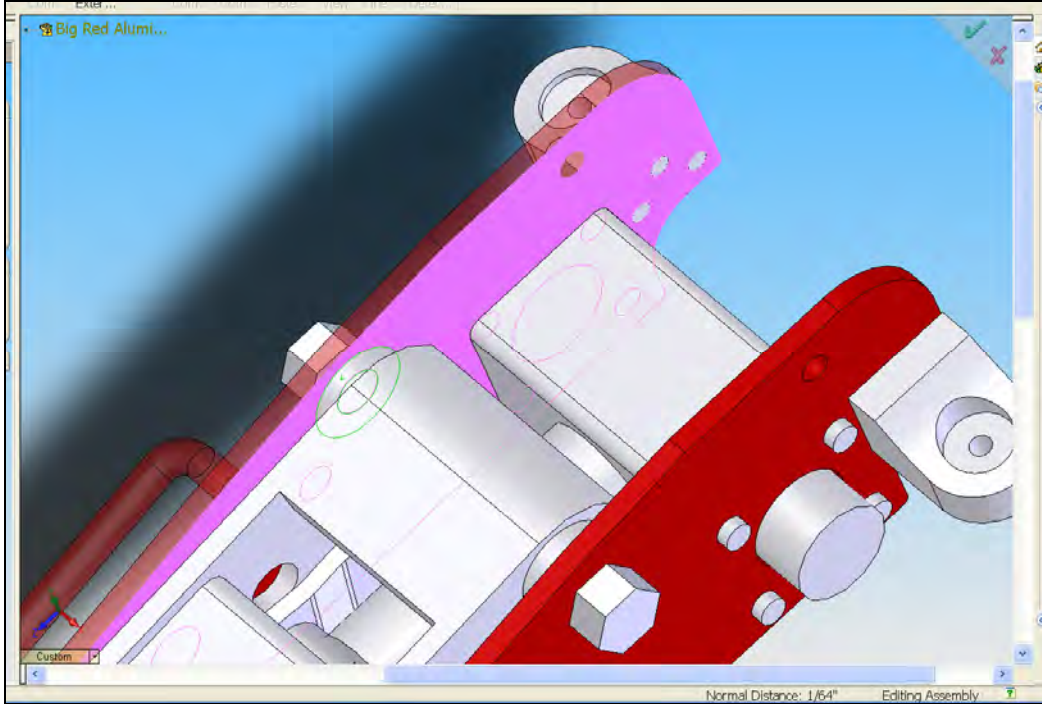

54) For **Faces for Target**, select the surface of the **Right Frame** as shown in the picture below. Under **Options**, select **Node to Surface**. Click **OK**. (Note: The **Right Frame** surface that you need to select is highlighted in pink.)

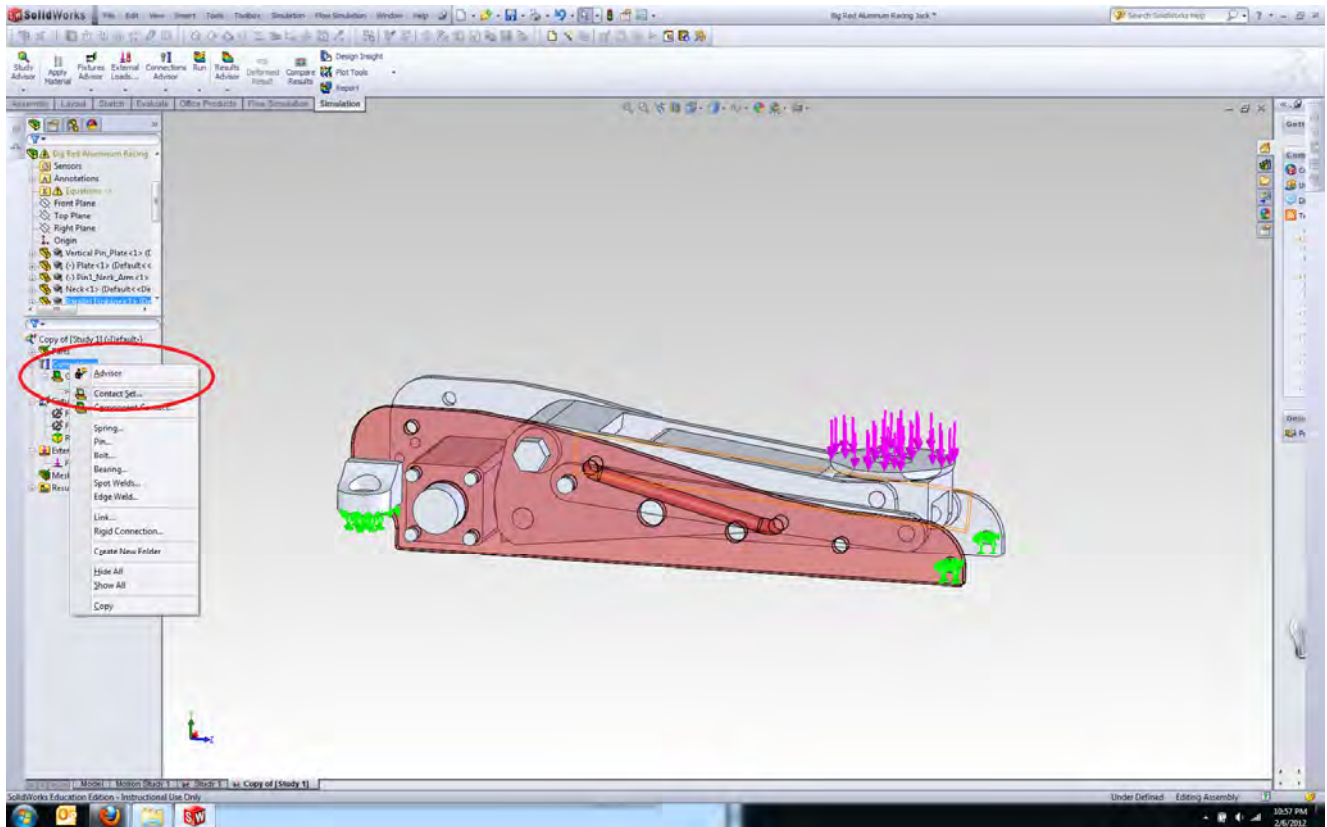

55) Right-click **Connections** and select **Contact Set**.



- 56) For  **Faces, Edges, Vertices for Source**, select the face of **Bottle Jack** as shown in picture below. (Note: The **Bottle Jack** surface that you need to select is highlighted in green.)

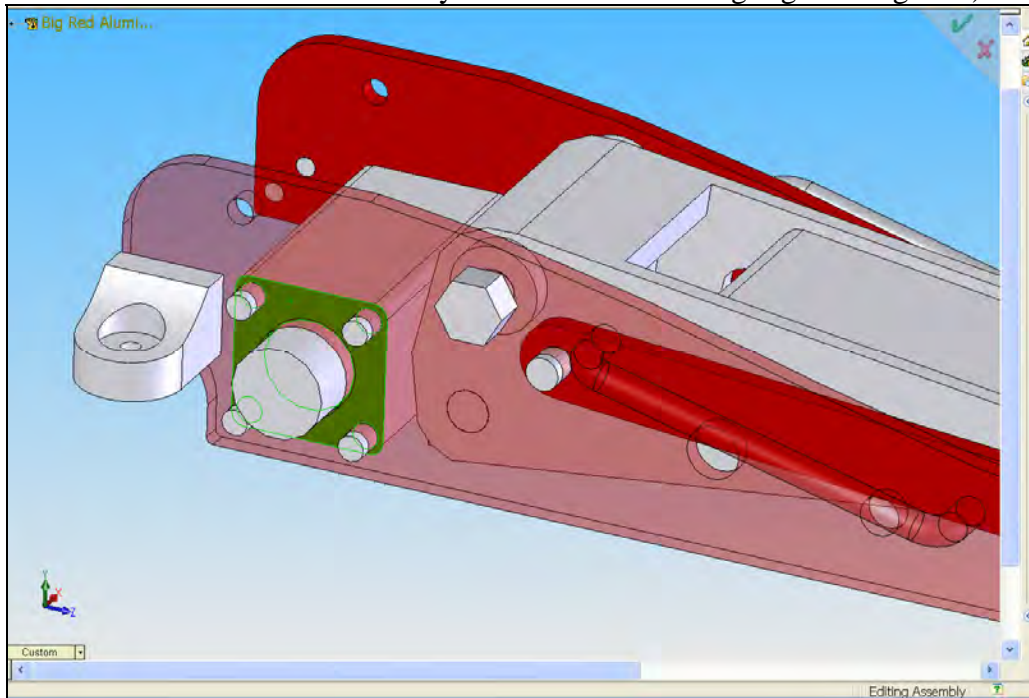

- 57) For  **Faces for Target**, select the surface of the **Right Frame** as shown in the picture below.

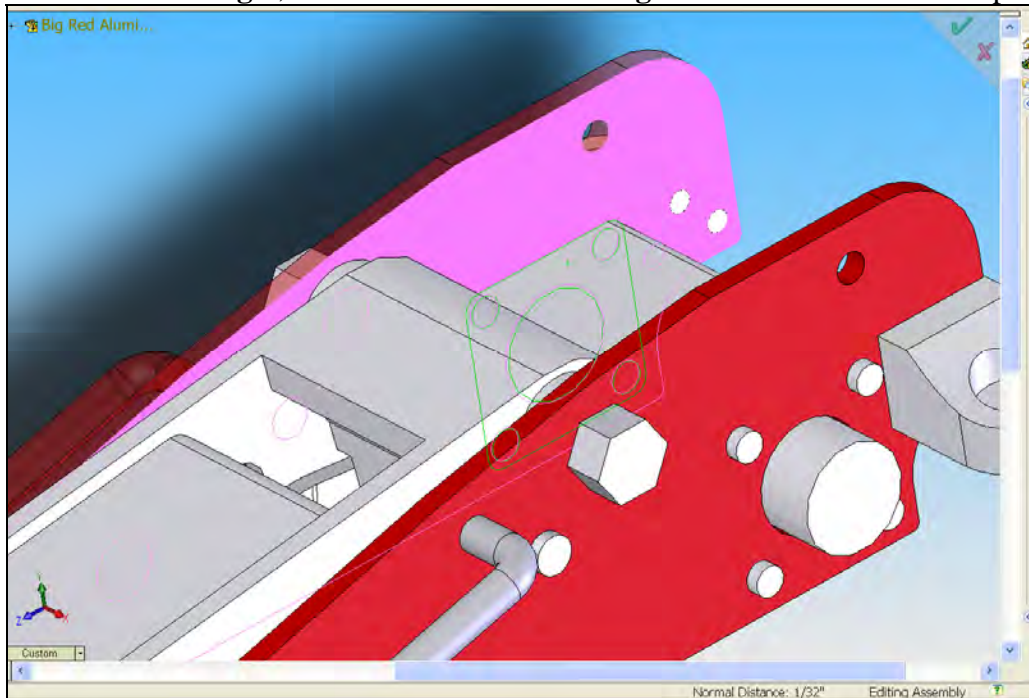



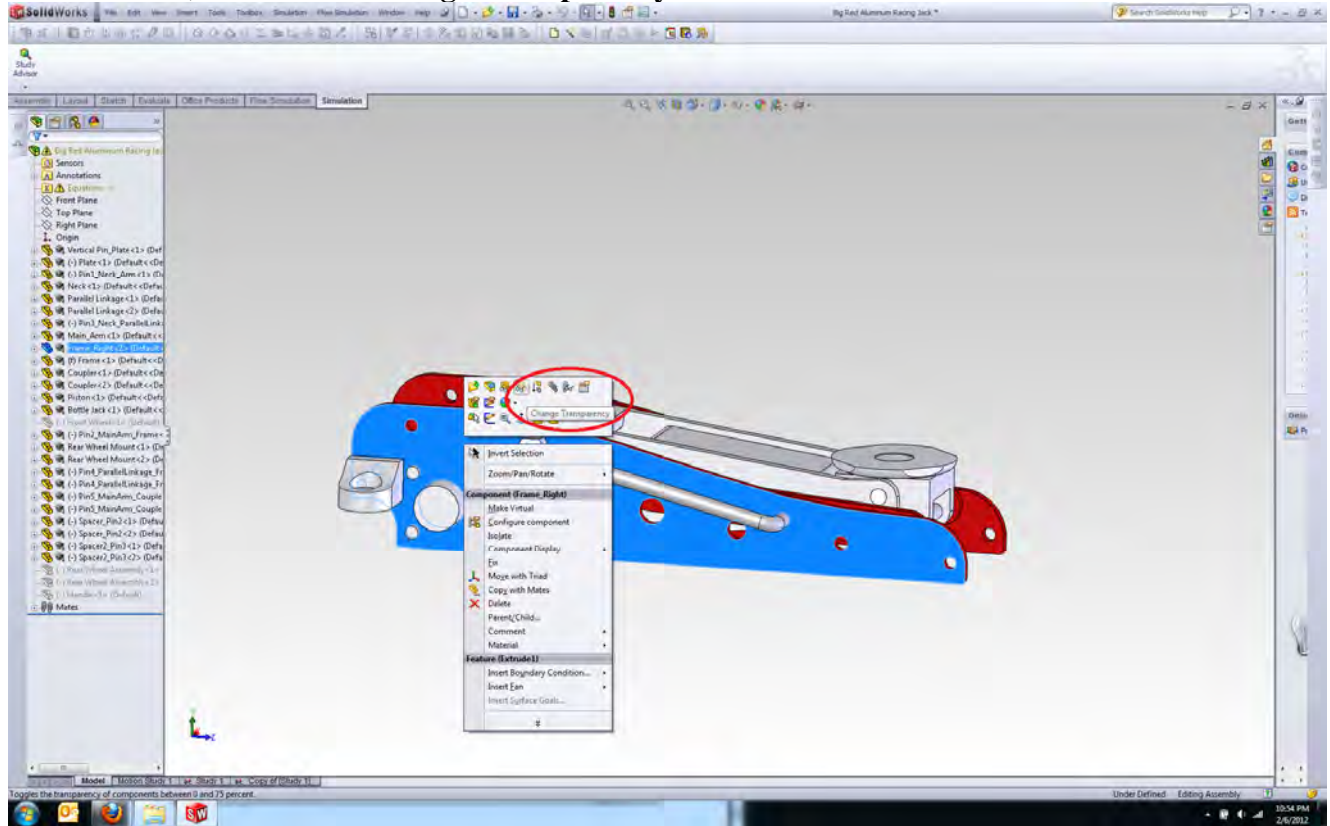

58) We have completed defining gaps to avoid interference of the parts with the right frame. We can now change the transparency of the right frame back to normal. Put the mouse pointer anywhere on right frame surface and right-click it. Then, select  **Change Transparency**.

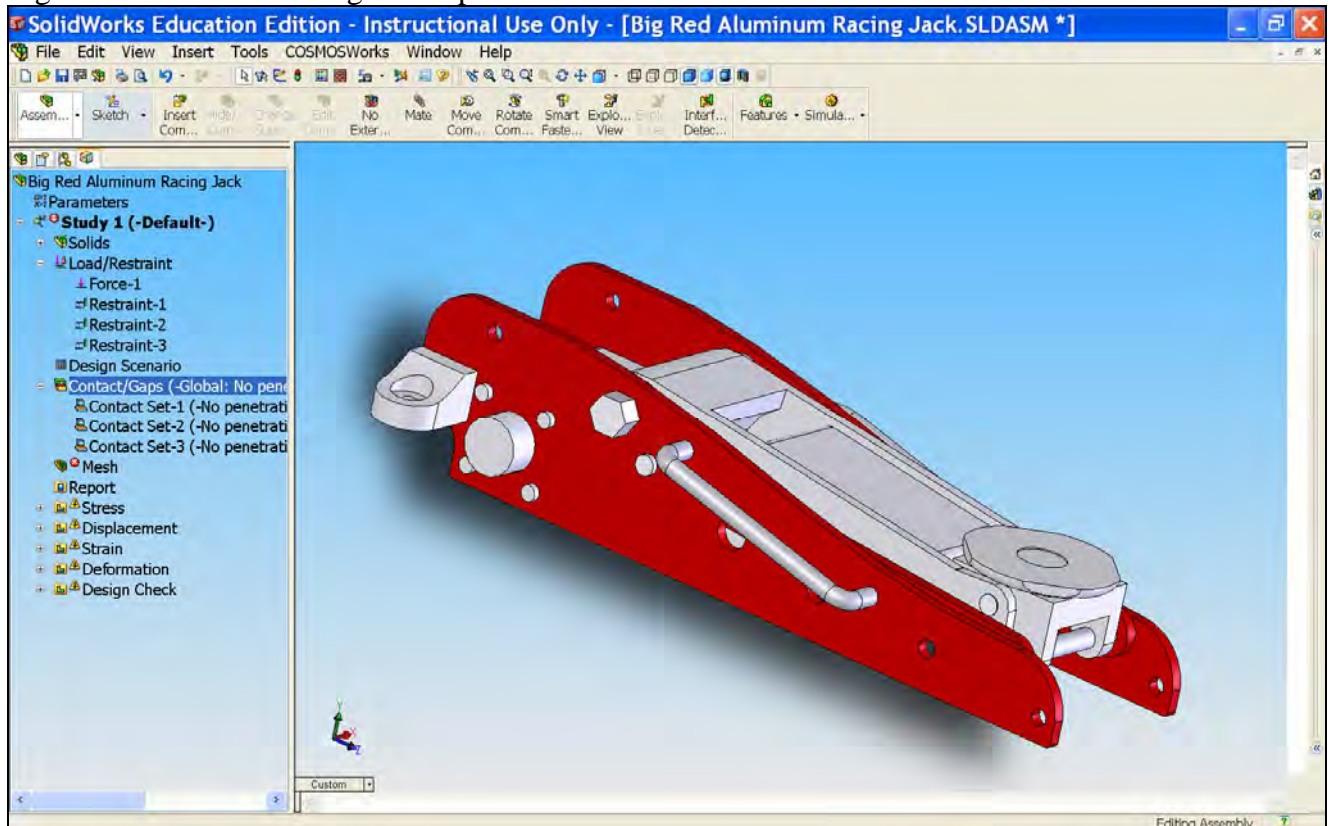

59) The Right Frame now is no longer transparent.



60) Now, let's fix the interference problem of the parts with the Left Frame. Put the mouse pointer anywhere on the left frame surface and right-click it. Then, select  **Change Transparency**.

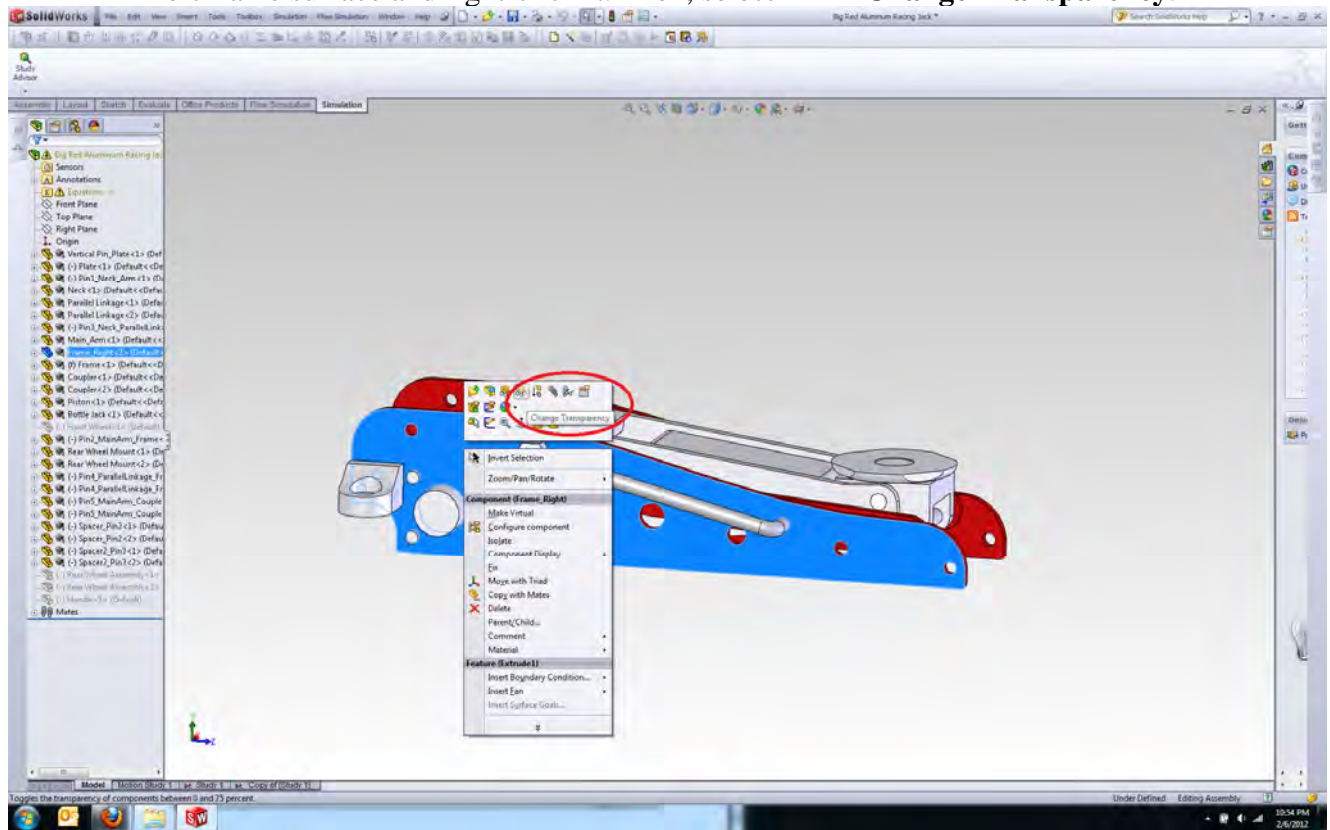

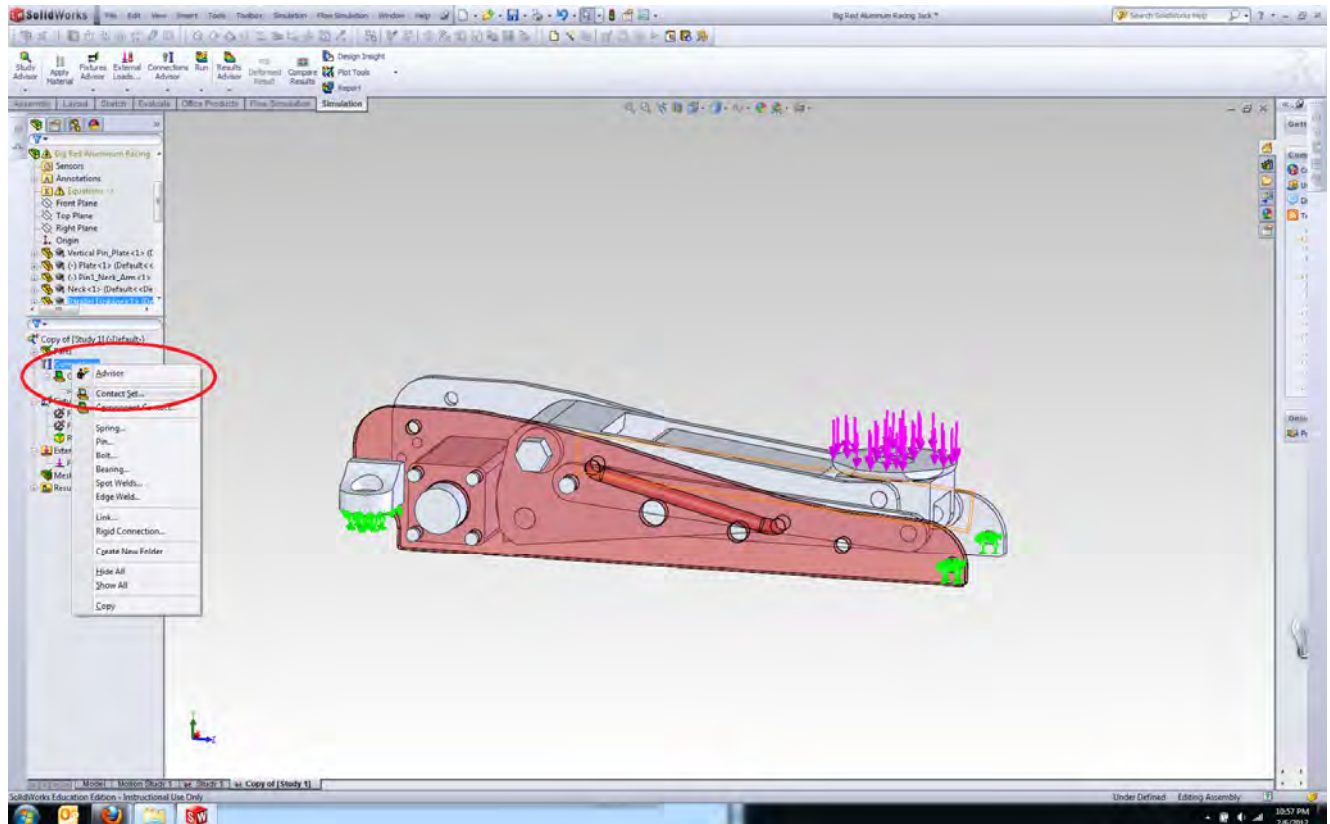

61) The left frame is now transparent Right-click **Connections** and select **Contact Set**.



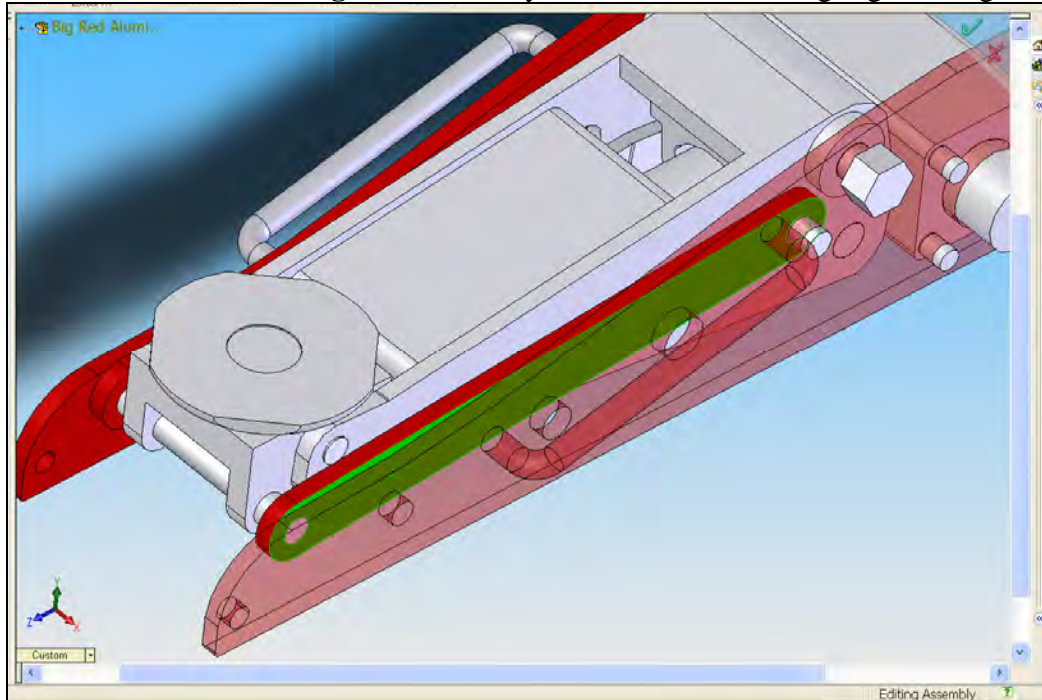

- 62) For  **Faces, Edges, Vertices for Source**, select the face of **Parallel Linkage** as shown in picture below.  
(Note: The **Parallel Linkage** surface that you need to select is highlighted in green.)



- 63) For  **Faces for Target**, select the surface of the **Left Frame** as shown in the picture below.

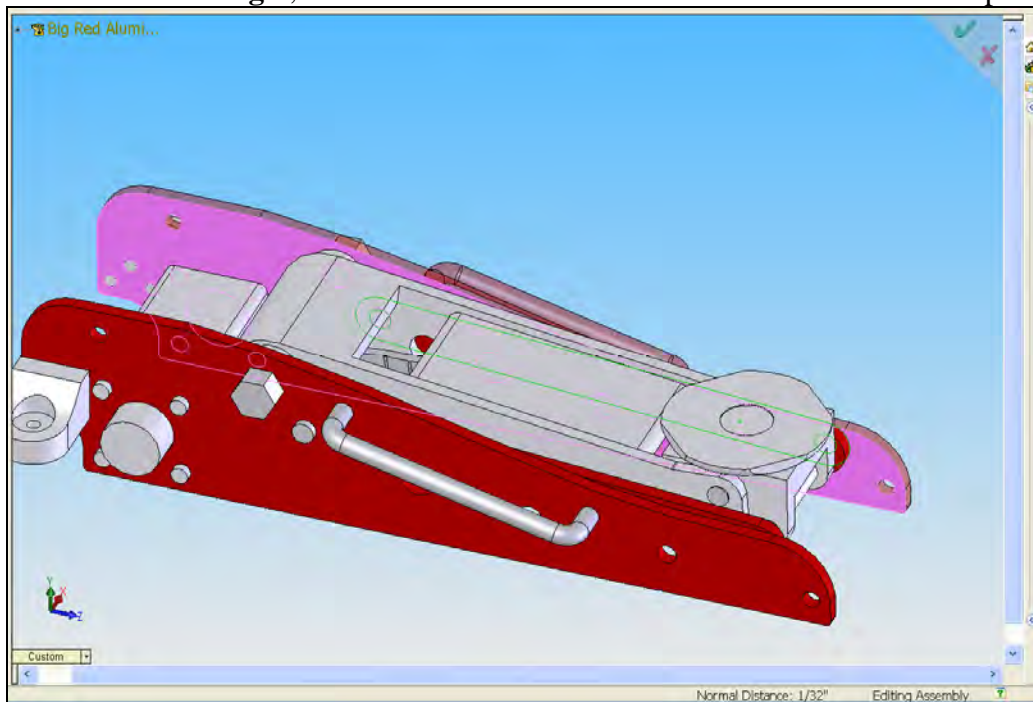

64) Right-click **Connections** and select **Contact Set**.

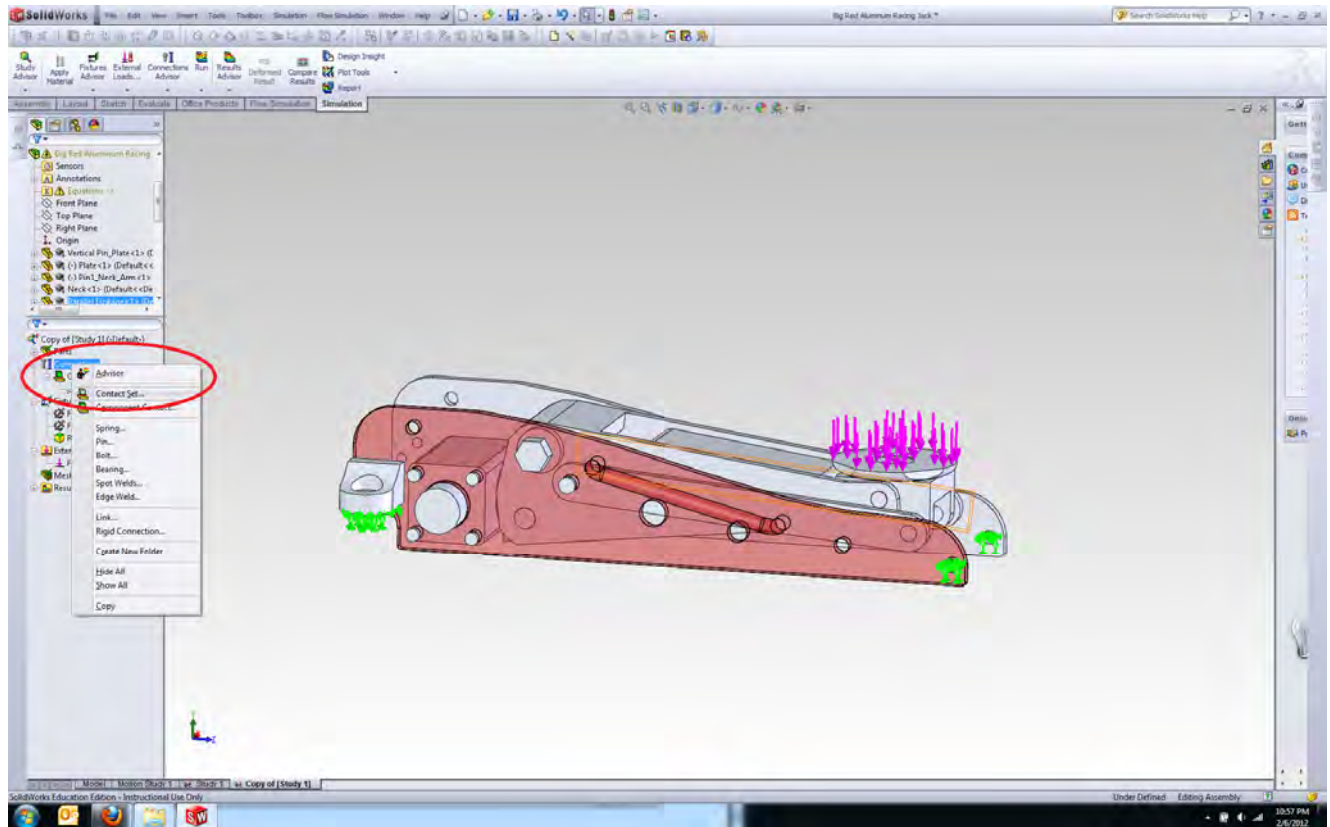

65) For  **Faces, Edges, Vertices for Source**, select the face of **Spacer Pin2<1>** as shown in picture below.  
(Note: The **Spacer Pin2<1>** surface that you need to select is highlighted in green.)

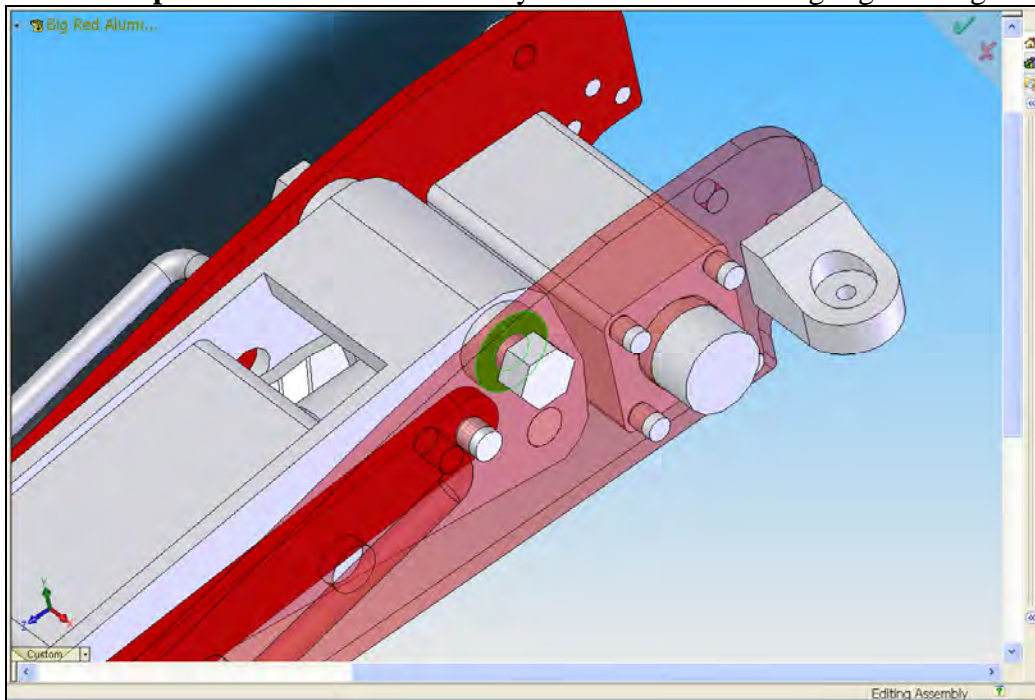



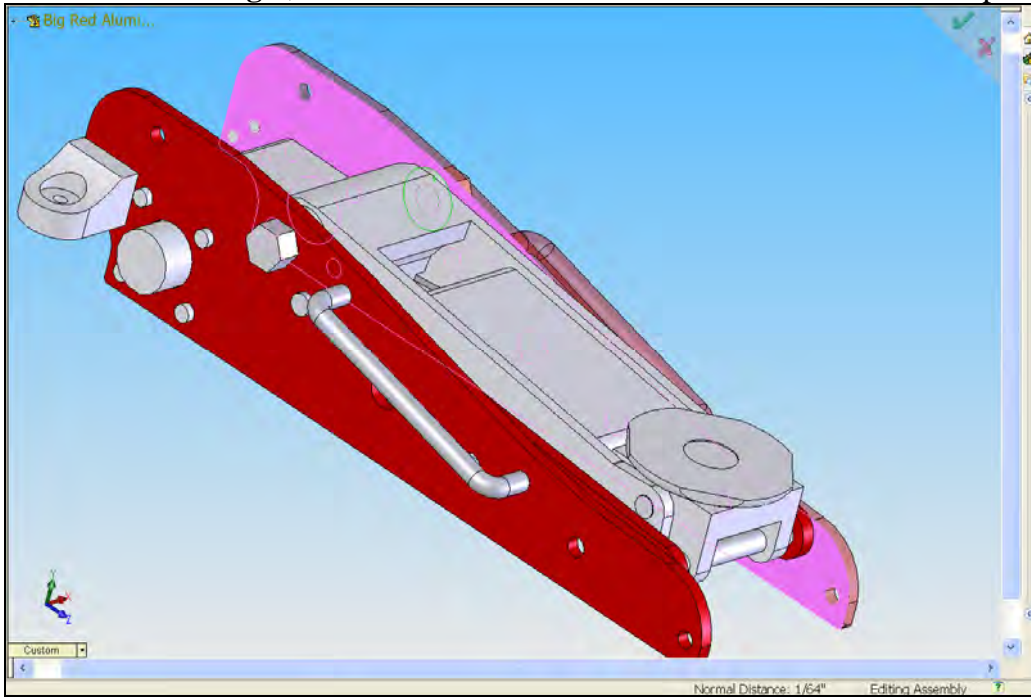

66) For  **Faces for Target**, select the surface of the **Left Frame** as shown in the picture below.

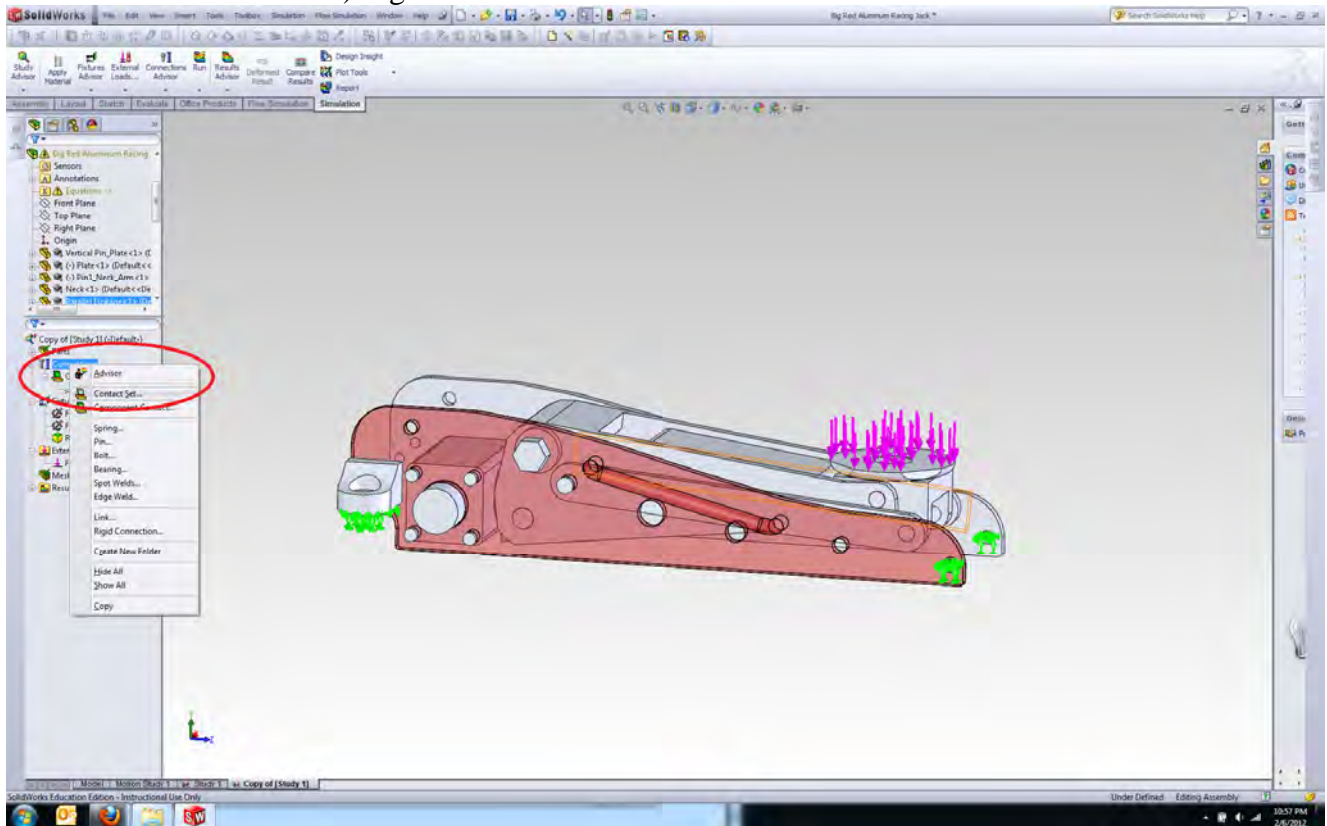

67) Right-click Connections and select Contact Set.



- 68) For  **Faces, Edges, Vertices for Source**, select the face of **Bottle Jack** as shown in picture below. (Note: The **Bottle Jack** surface that you need to select is highlighted in green.)

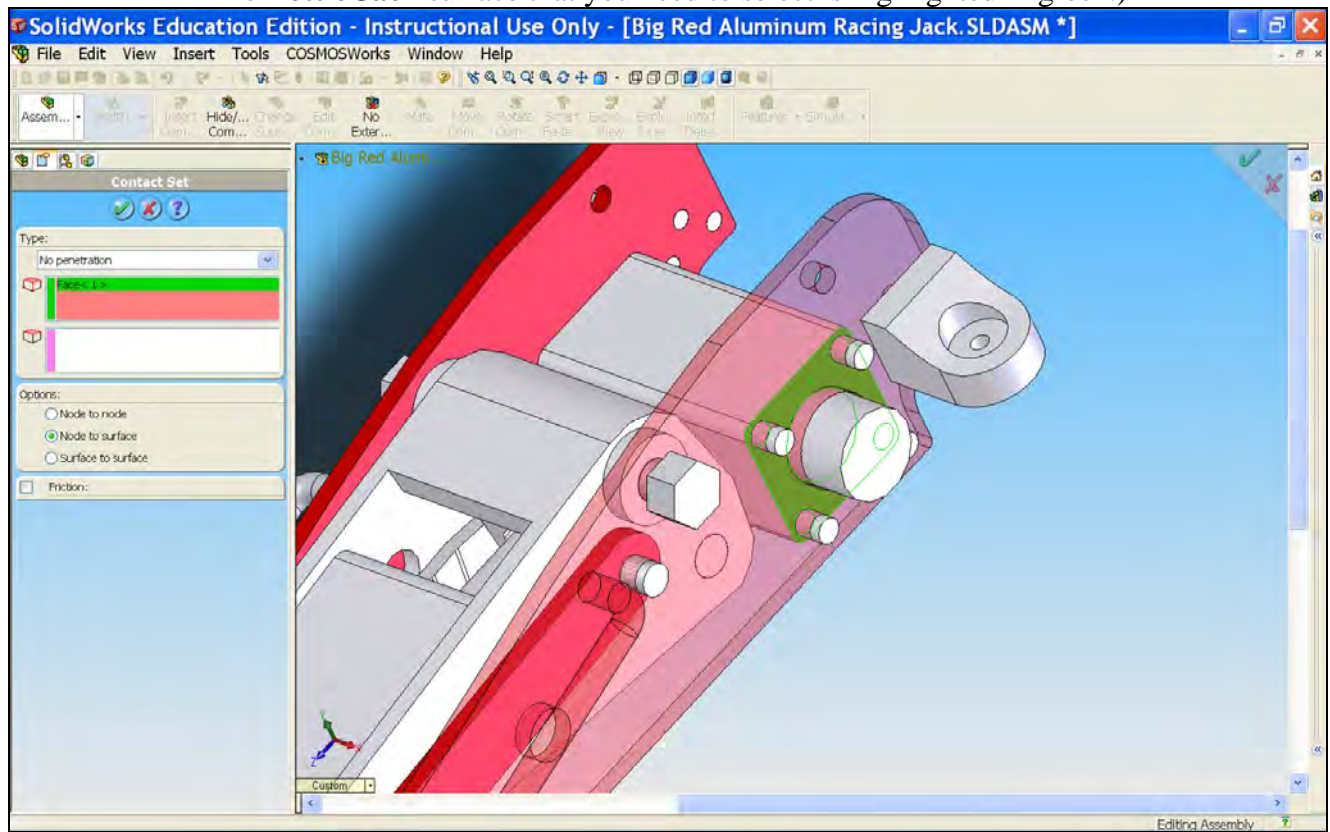

- 69) For  **Faces for Target**, select the surface of the **Left Frame** as shown in the picture below. Under **Options**, select **Node to Surface**. Click **OK**. (Note: The **Left Frame** surface that you need to select is highlighted in pink.)

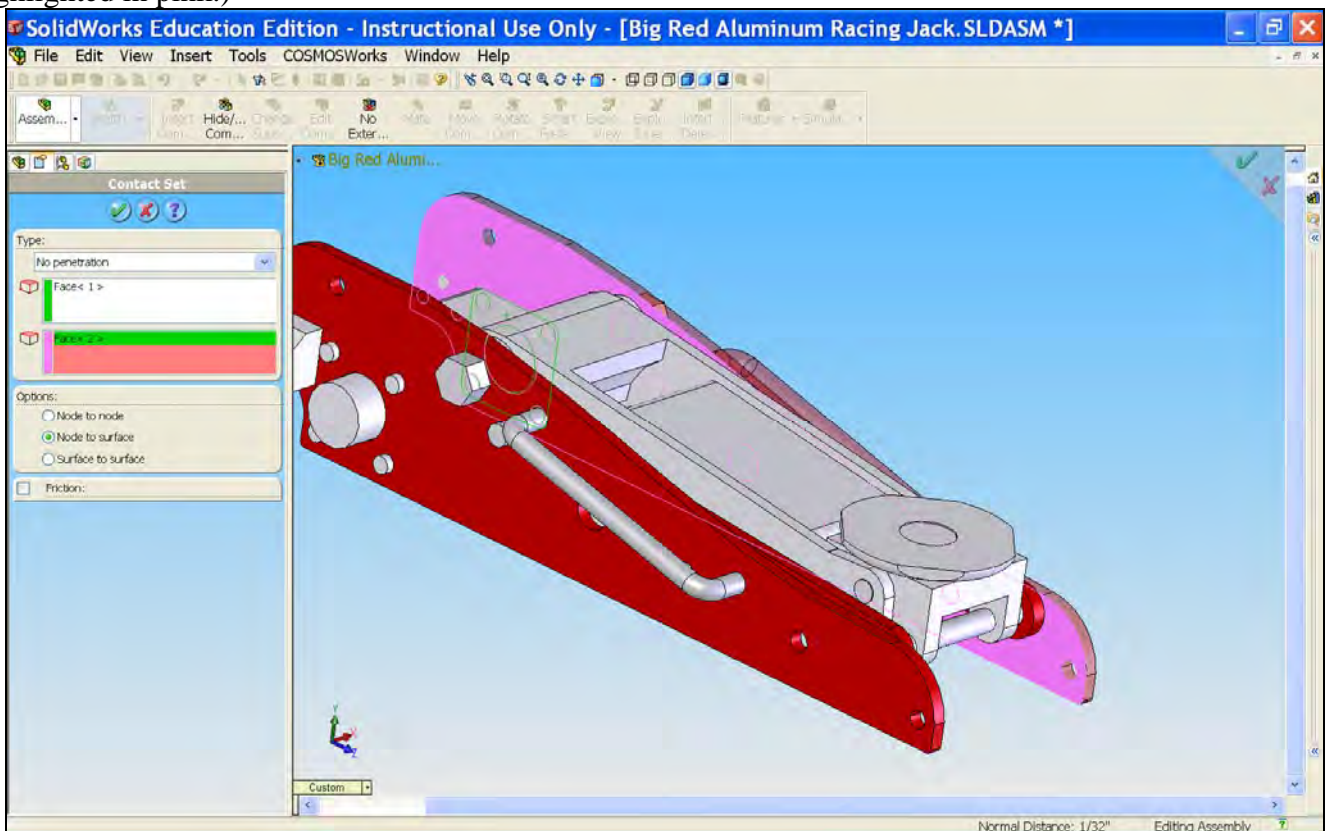



70) We have completed defining gaps to avoid interference of the parts with the left frame. We can now change the transparency of the left frame back to normal. Put the mouse pointer anywhere on left frame surface and right-click it. Then, select  **Change Transparency**.

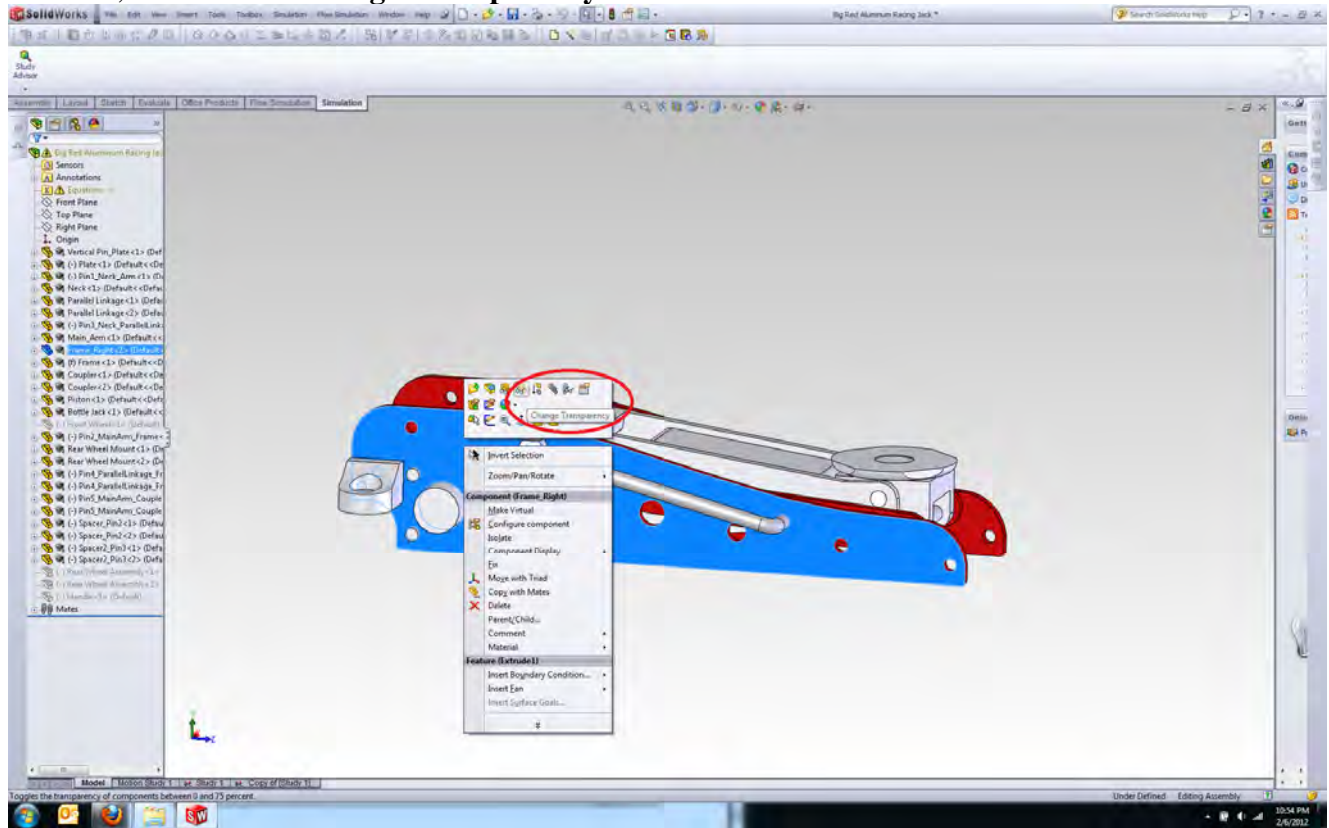

71) The left frame now is no longer transparent.

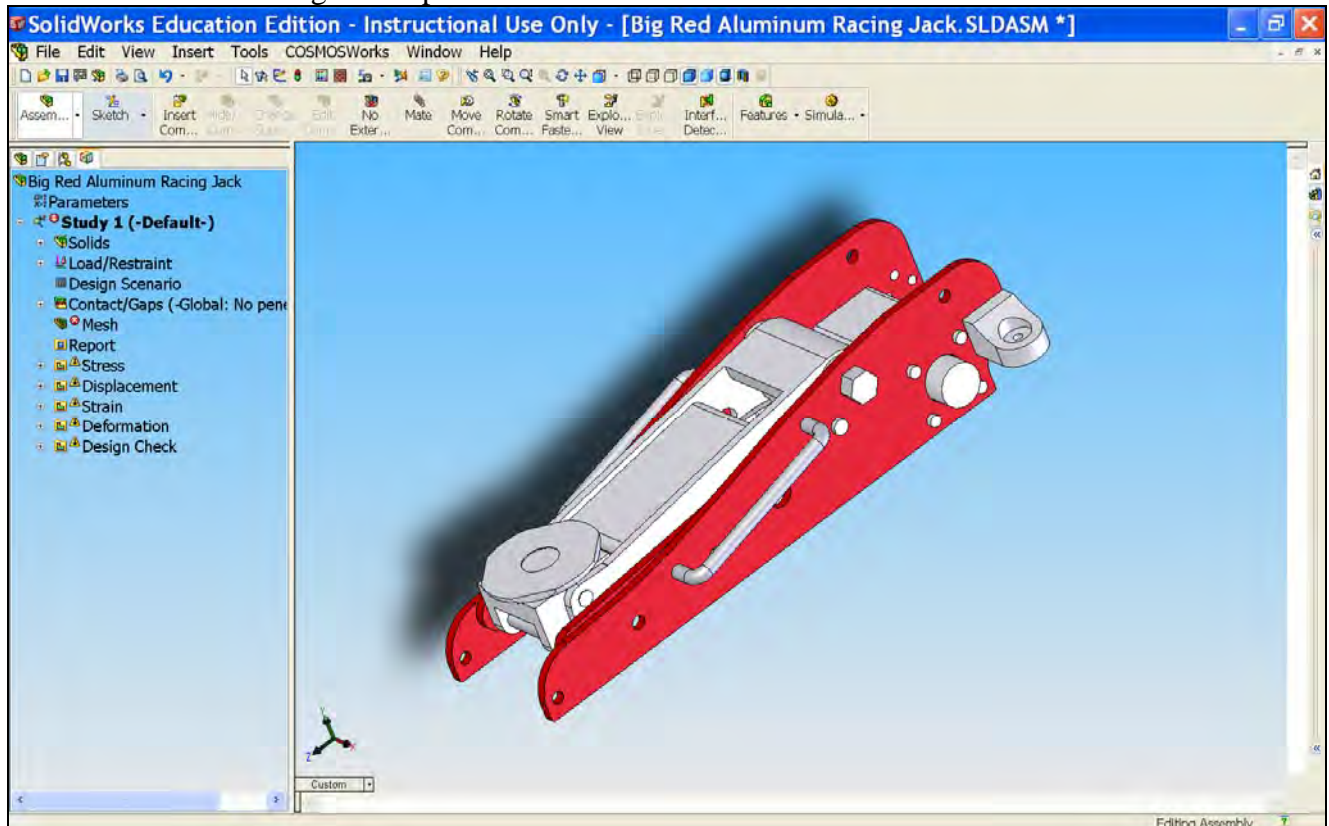

72) Right-click **Mesh** and select **Create Mesh**.

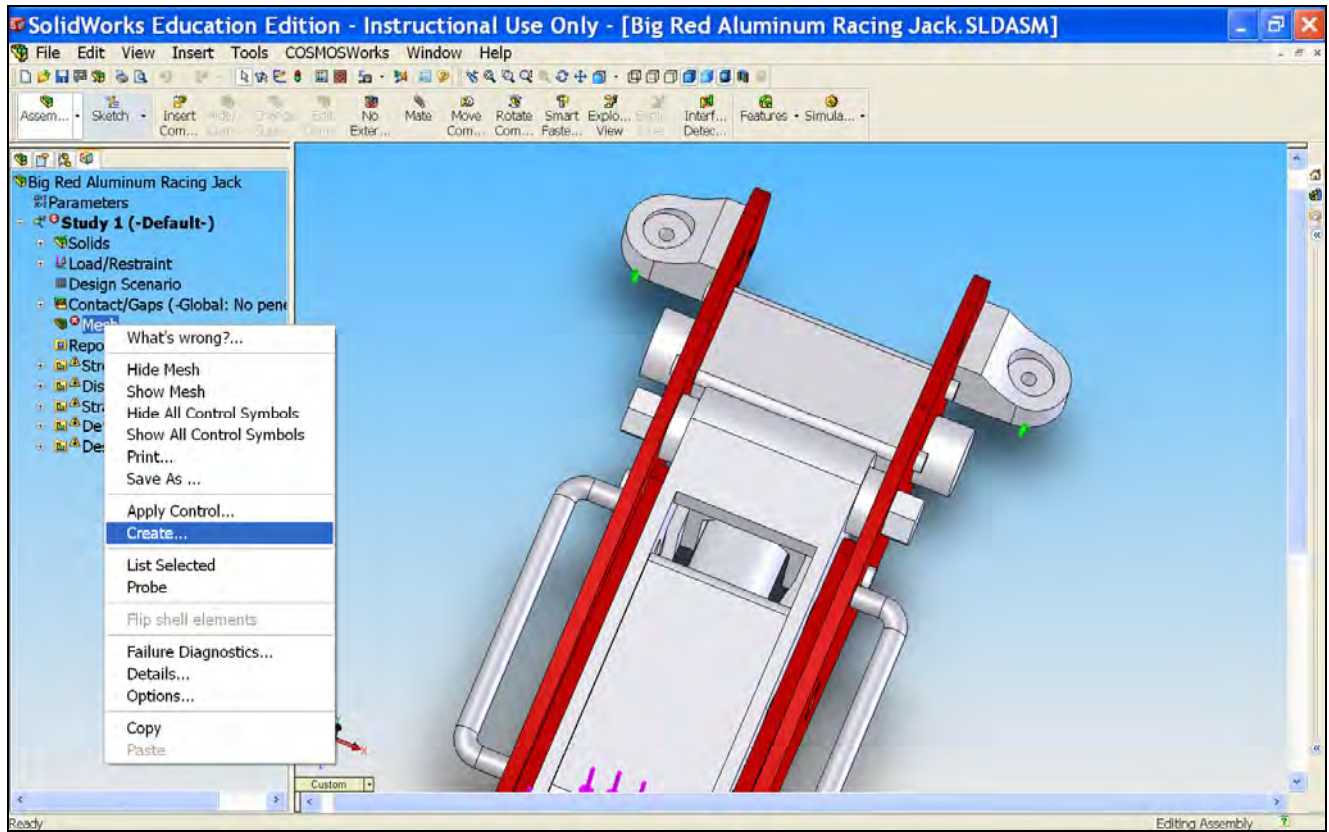

73) Click **OK** when this message prompts.

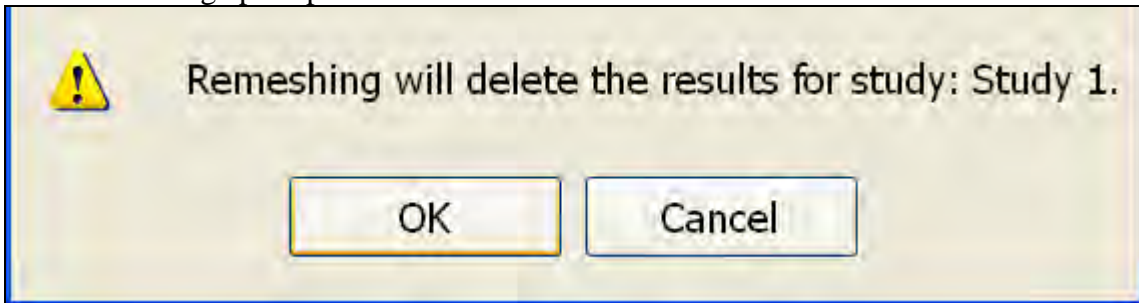

74) Click **OK** to accept the default values.

75) Re-meshing is now complete.



## 76) Click Run Study

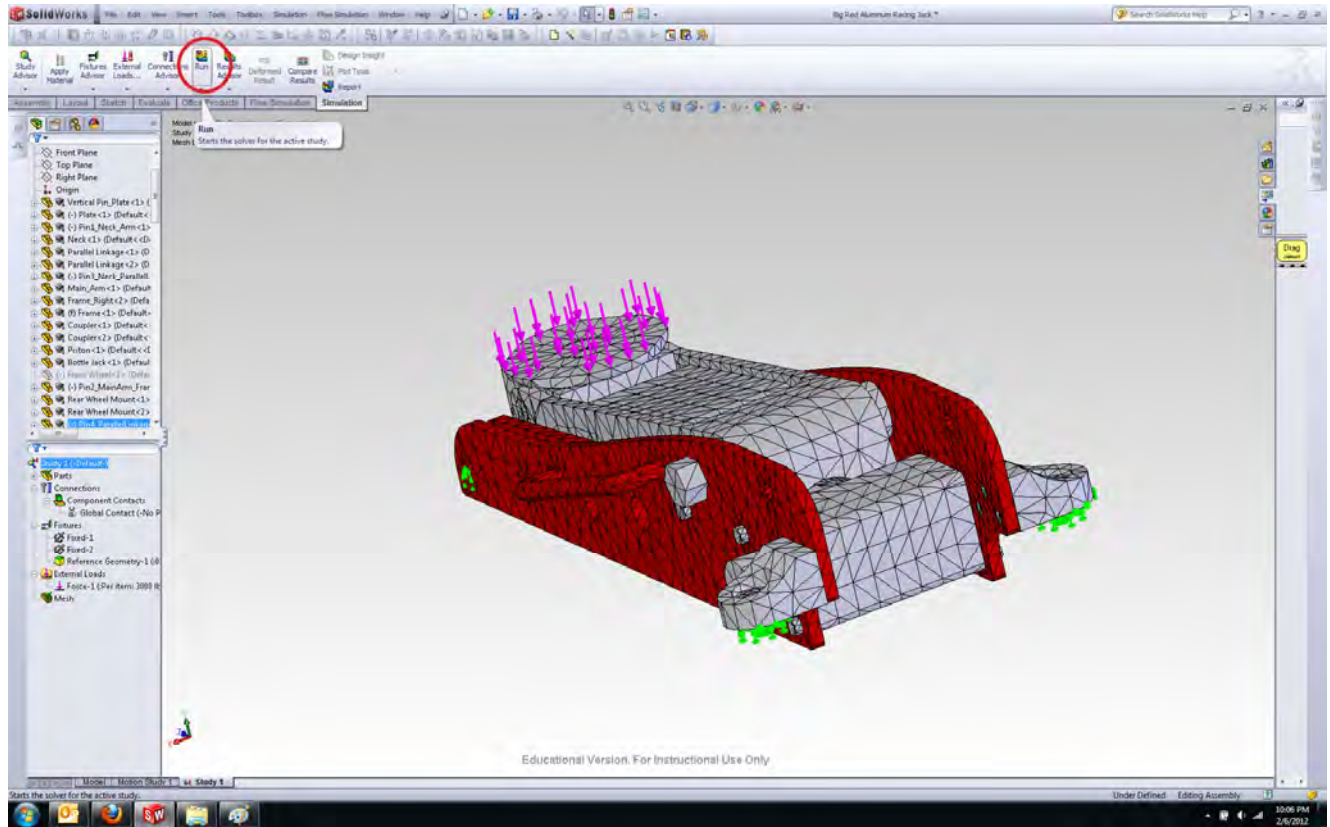

77) SolidWorks is now running the FEA analysis.

78) SolidWorks has completed the analysis.

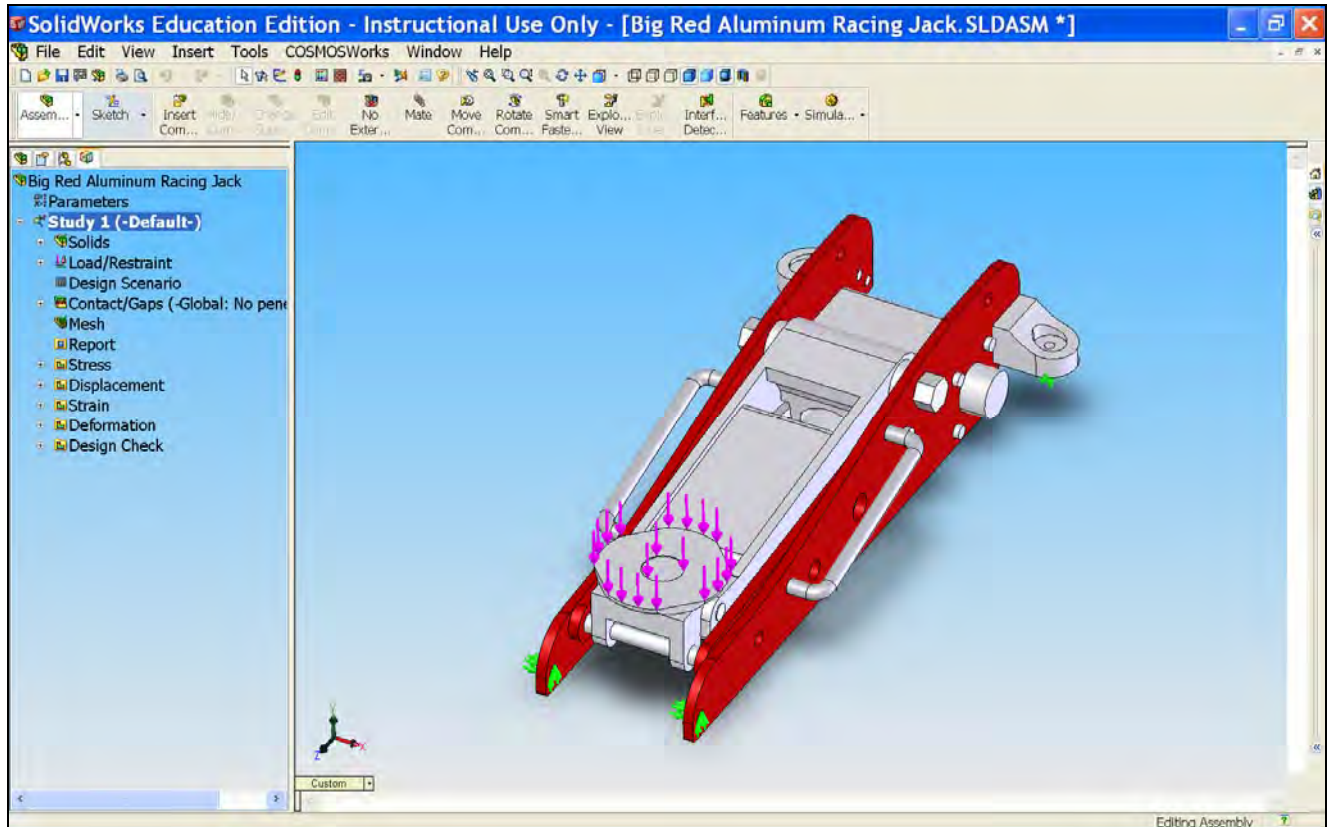

79) The von Mises Stress is shown by default.

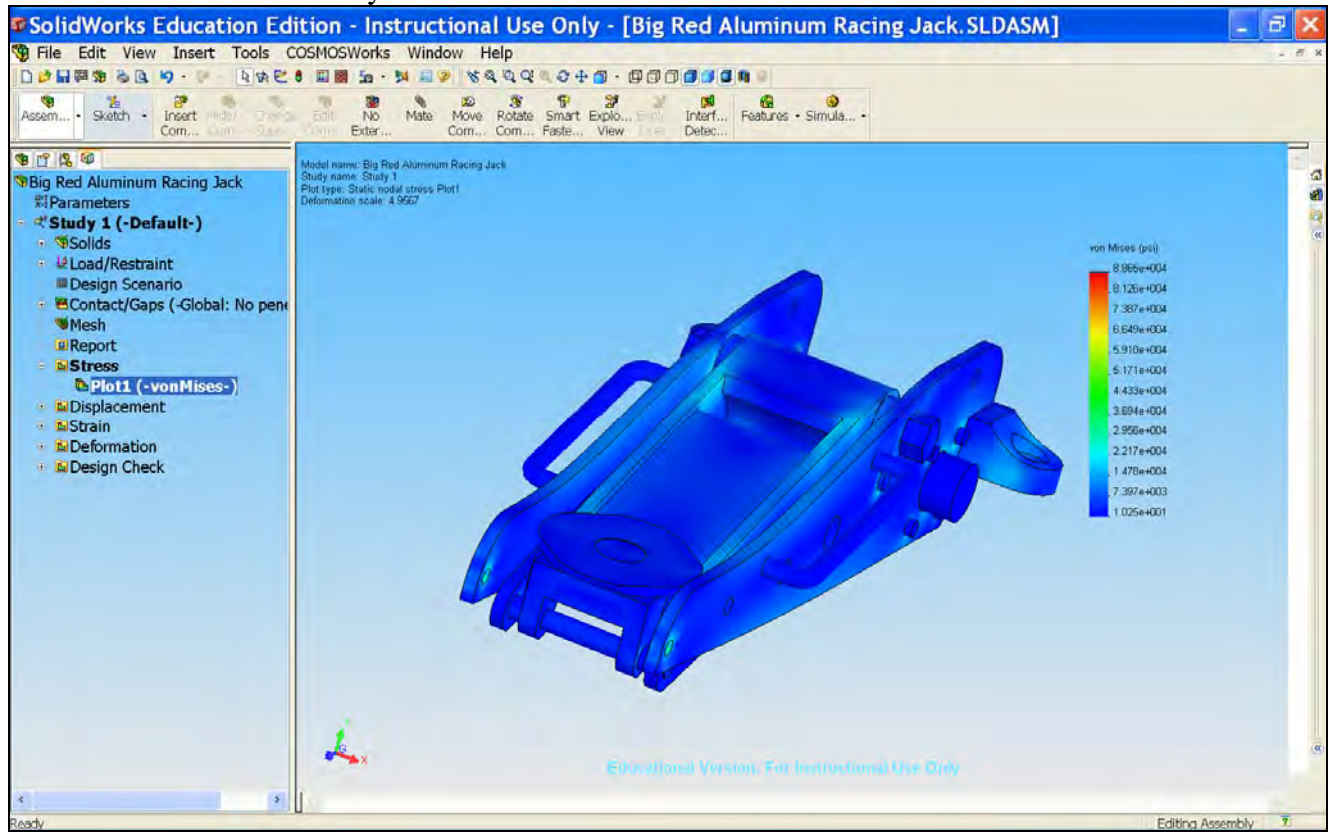



80) Go to **Simulation** menu on top, then go to **Result Tools** and select **Animate**.

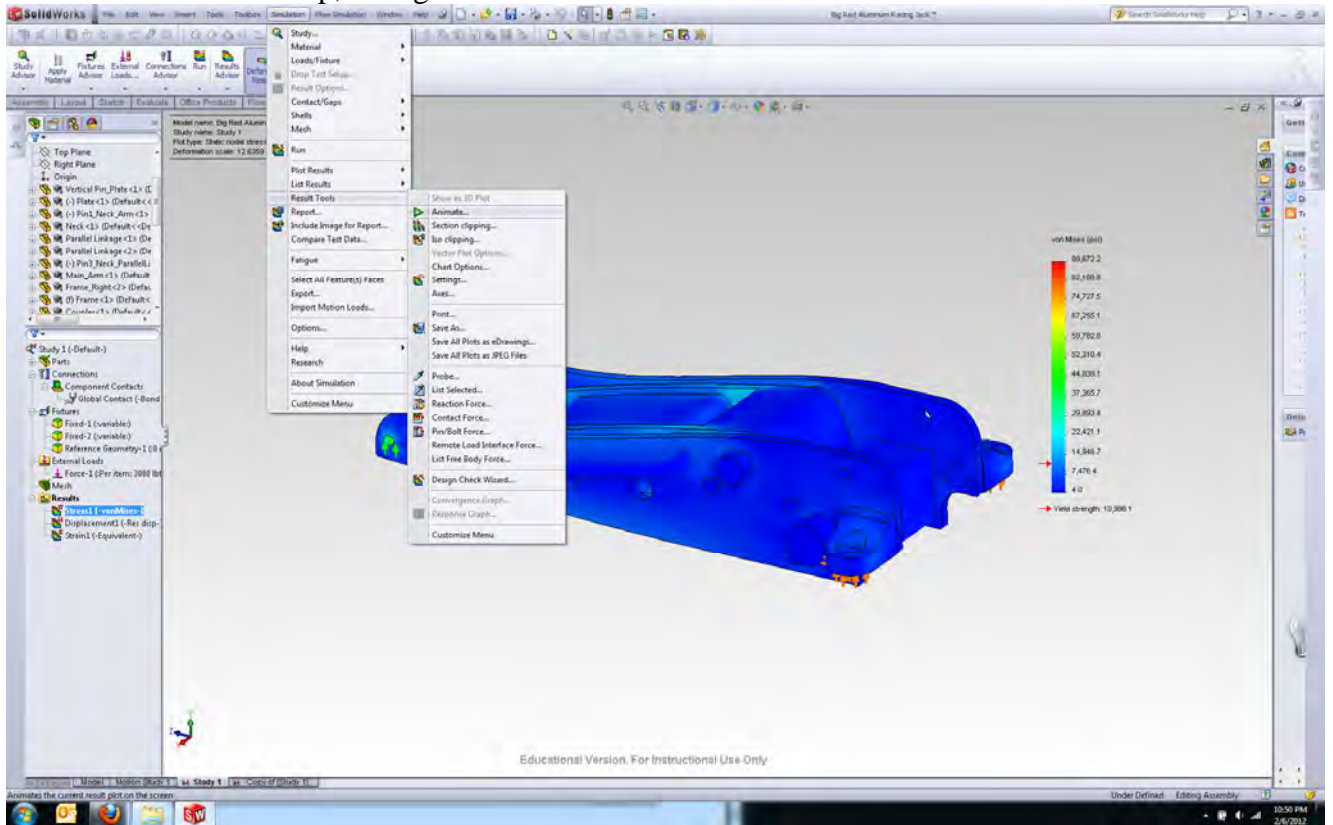

81) Hit the  play button to run the animation.

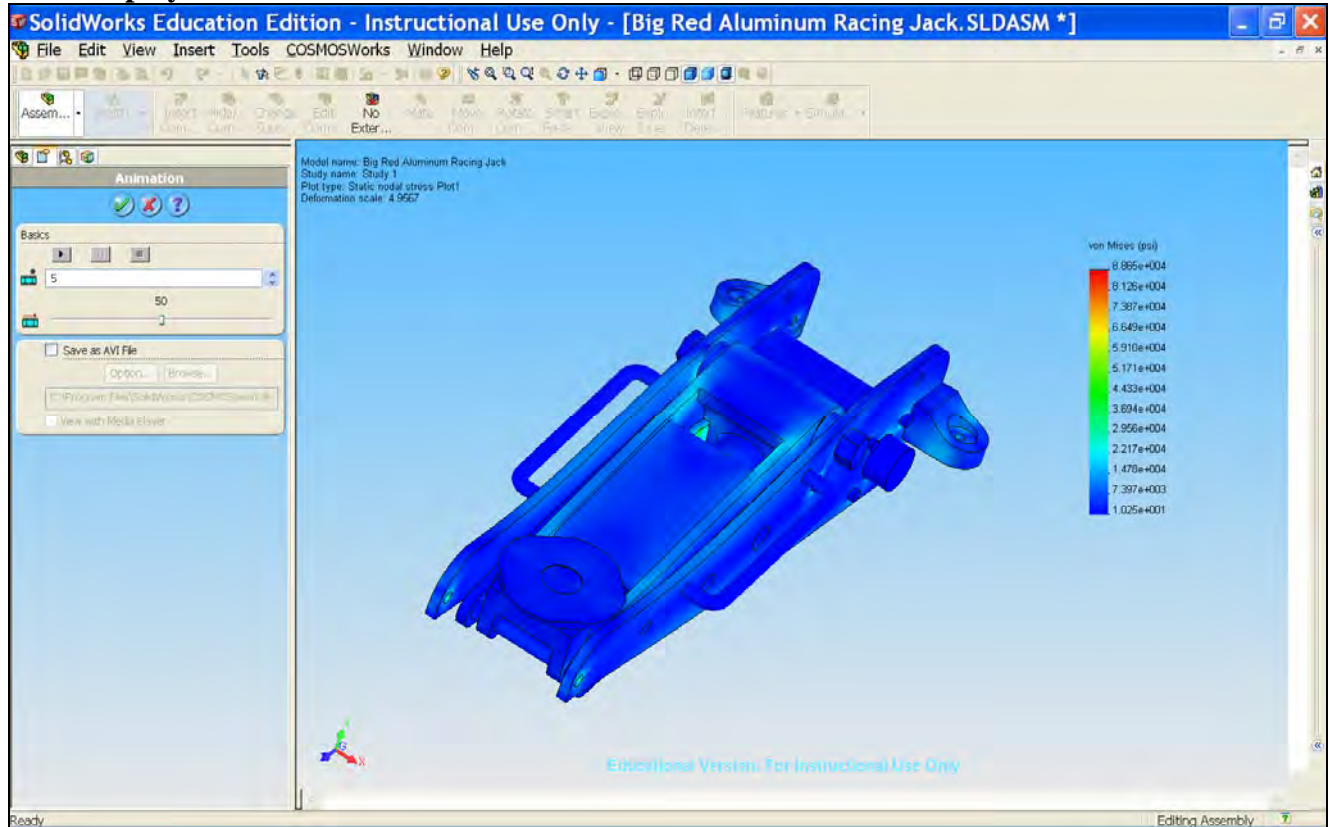

82) Note that parts interference no longer occurs.

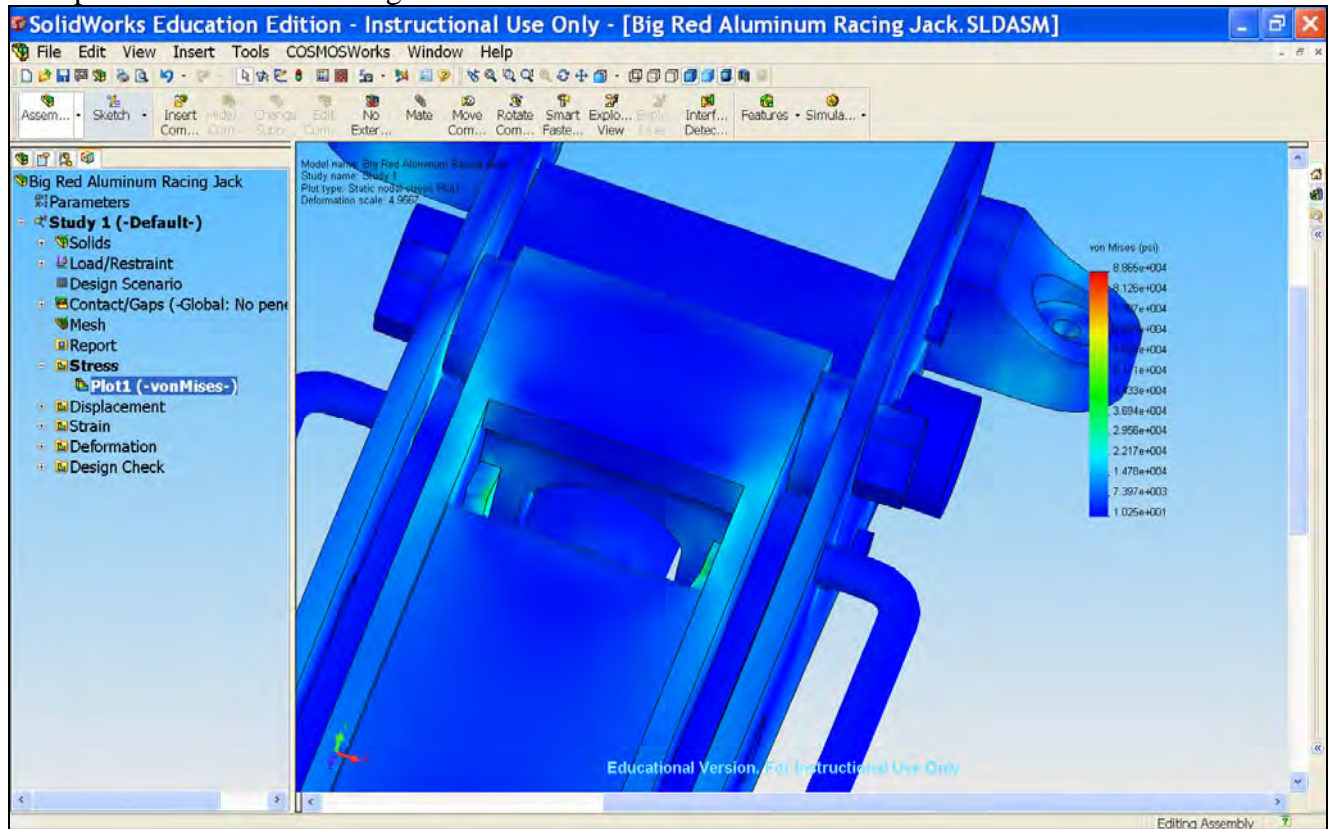



83) No more interference.

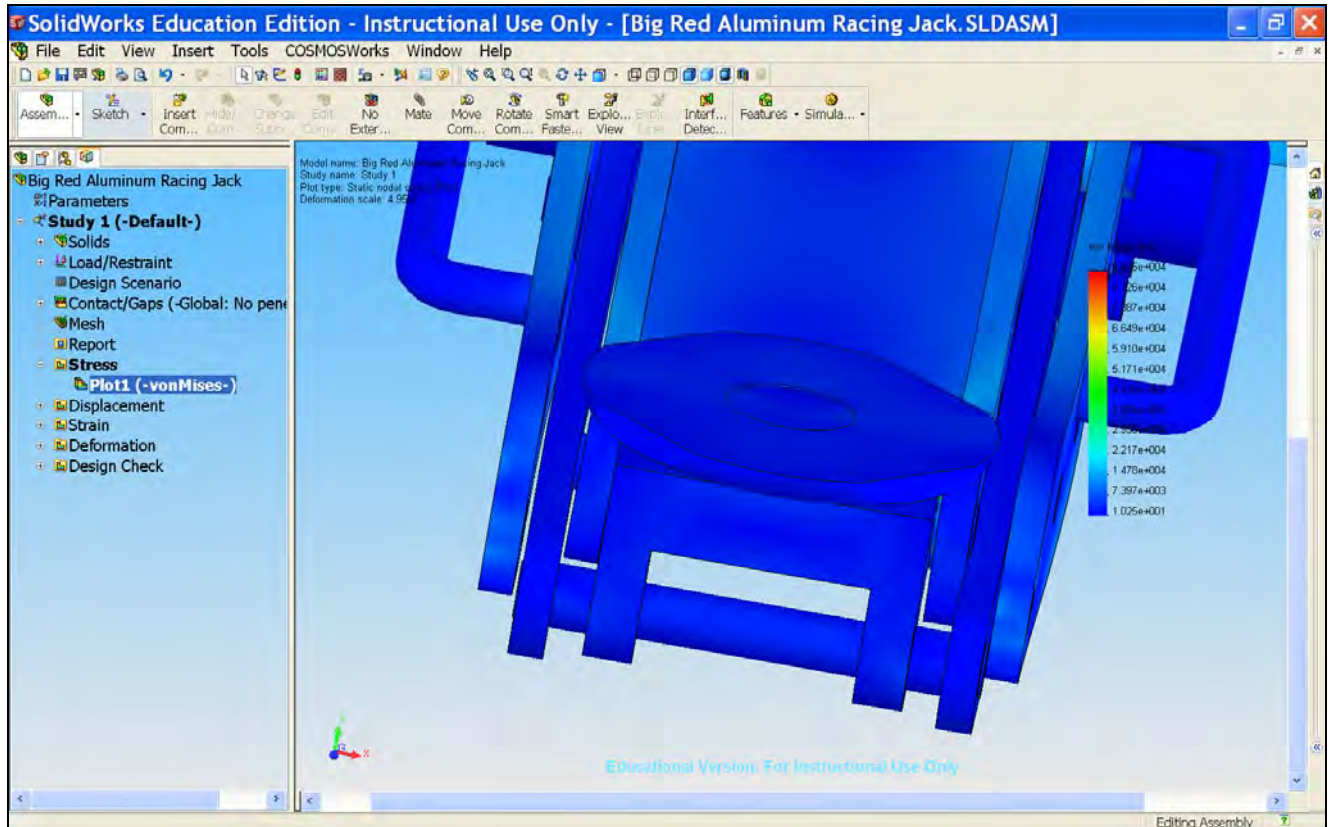

84) Click on Simulation > Design Check wizard

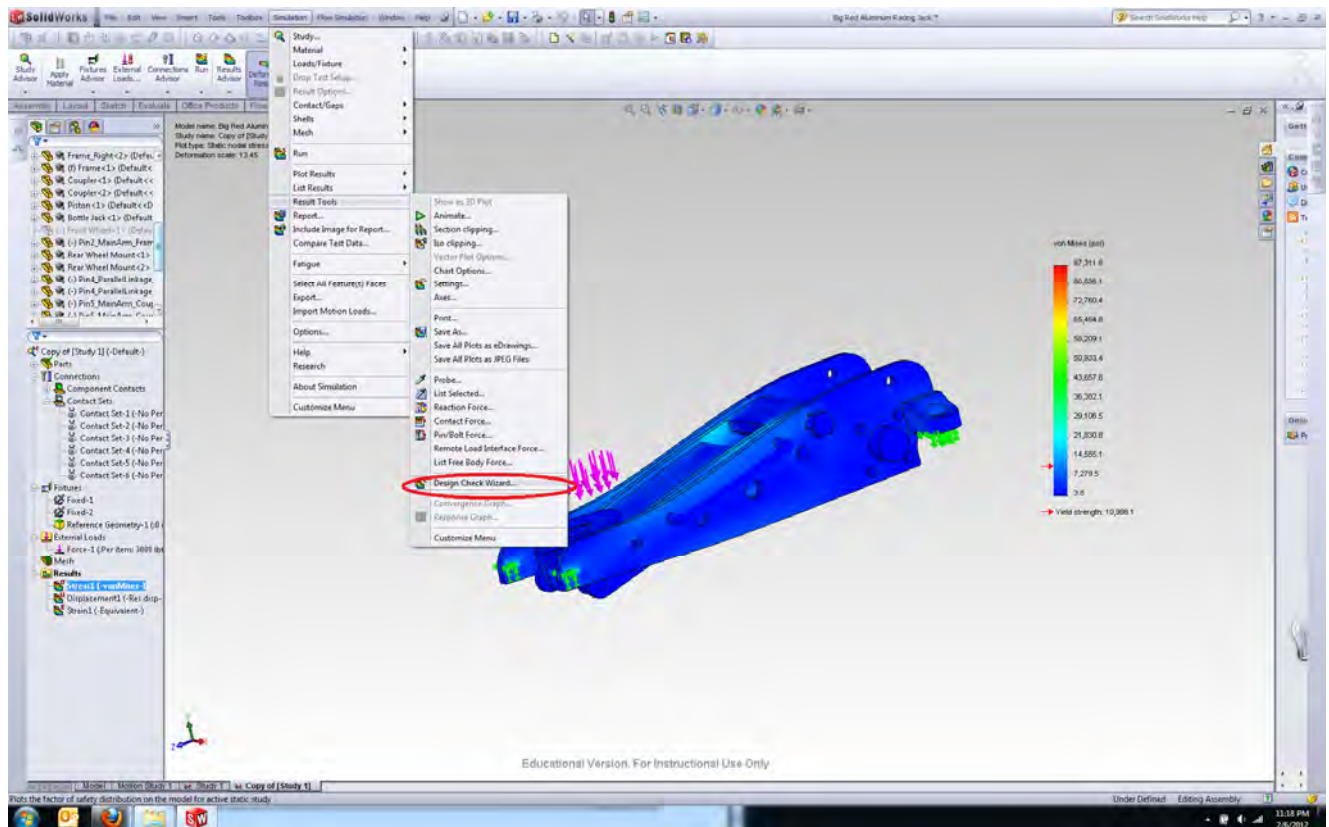

85) Click OK to use default Settings

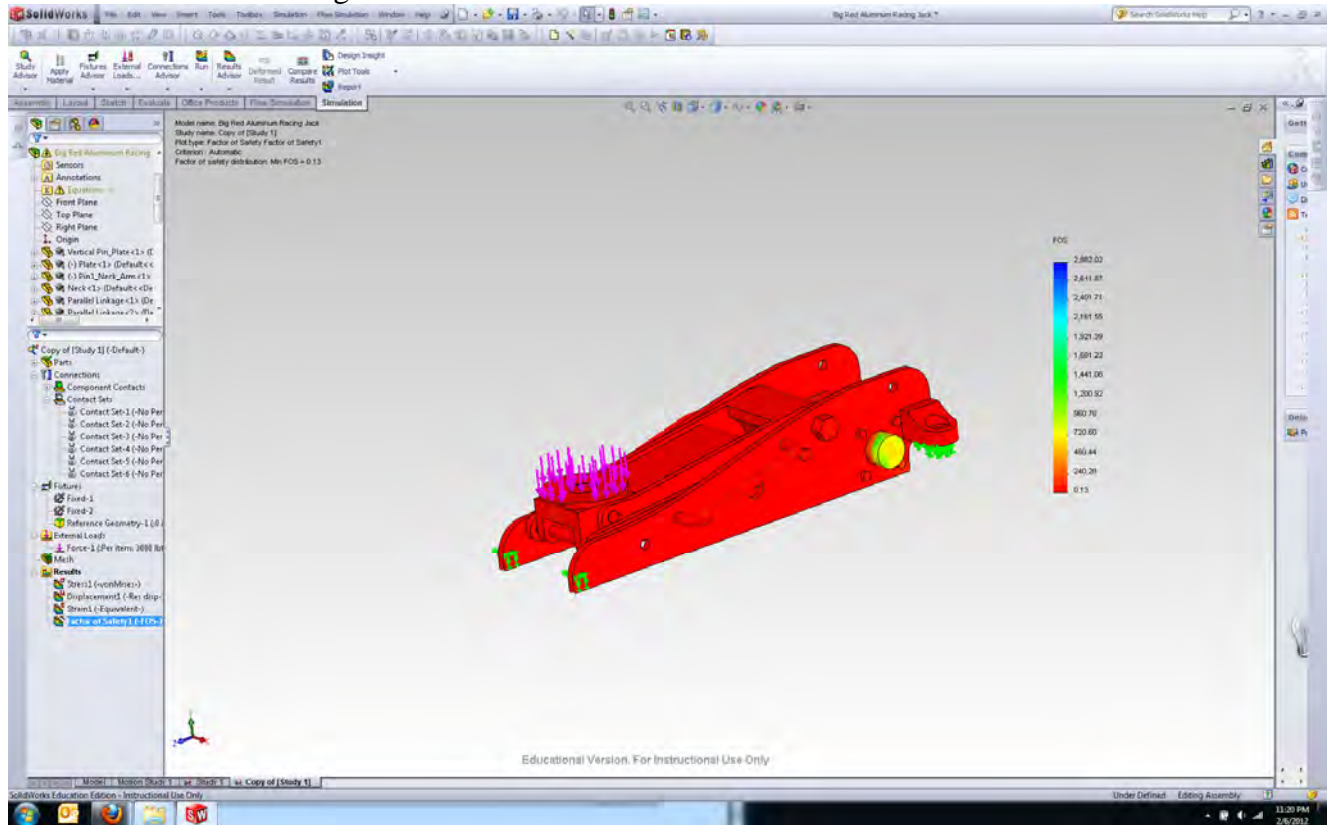

86) Now, let us find out the safety factor of individual component. Since the **Main Arm** is one of the most important parts that determine how much load the floor jack can support, let us plot the safety factor of the **Main Arm**. Right-click **Factory of Saftey** and **Edit Definition**.

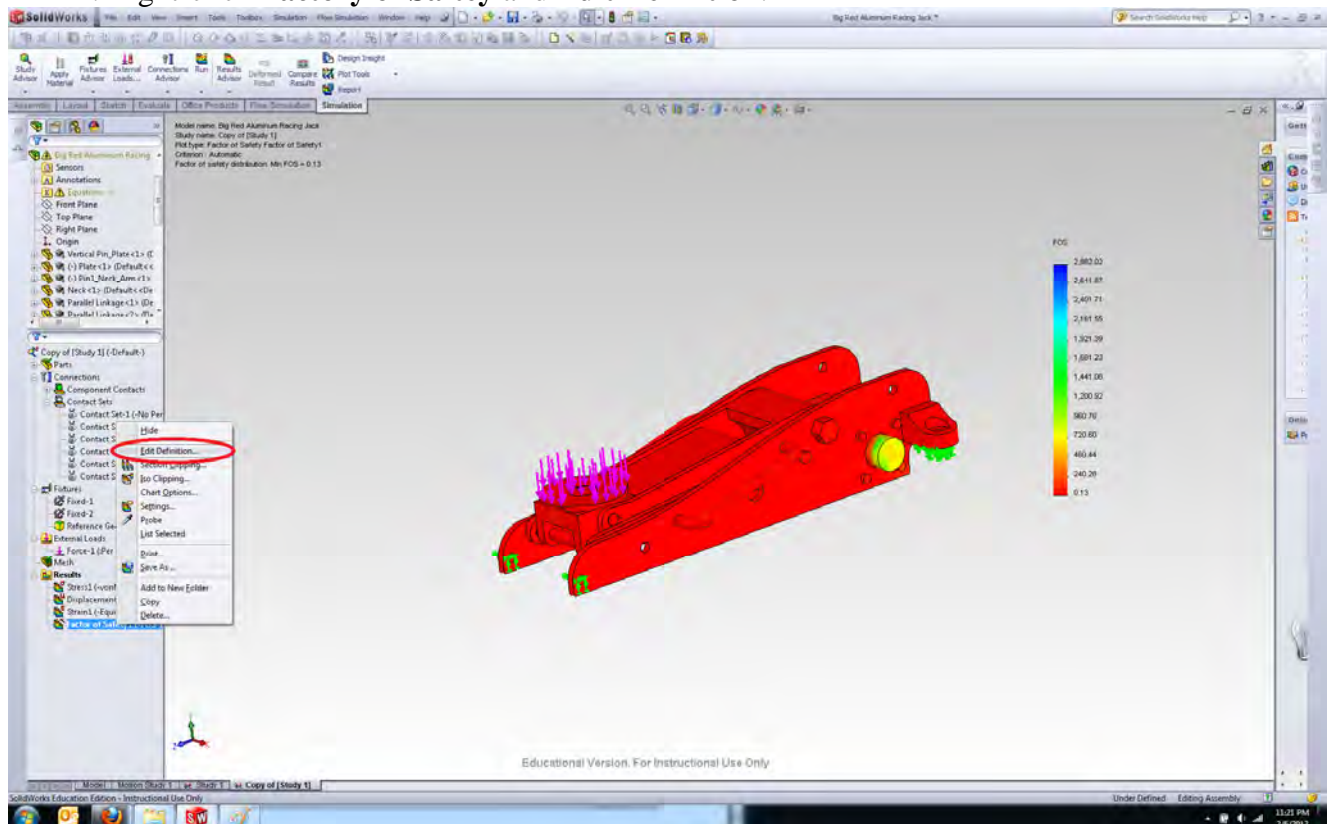



87) In the Top Box, select **Main Arm** and for **Criterion**, select **Max von Mises Stress**. Click **OK**.

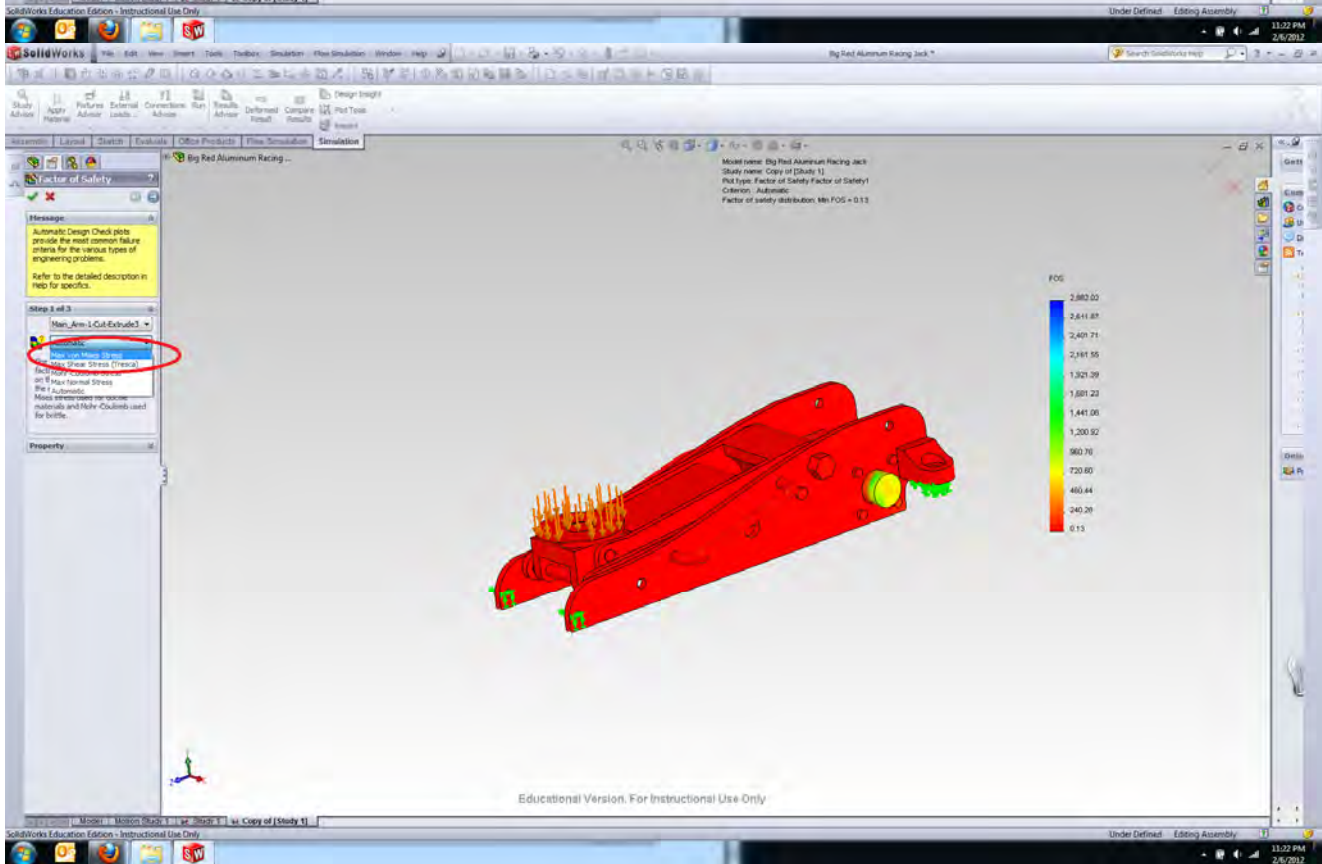
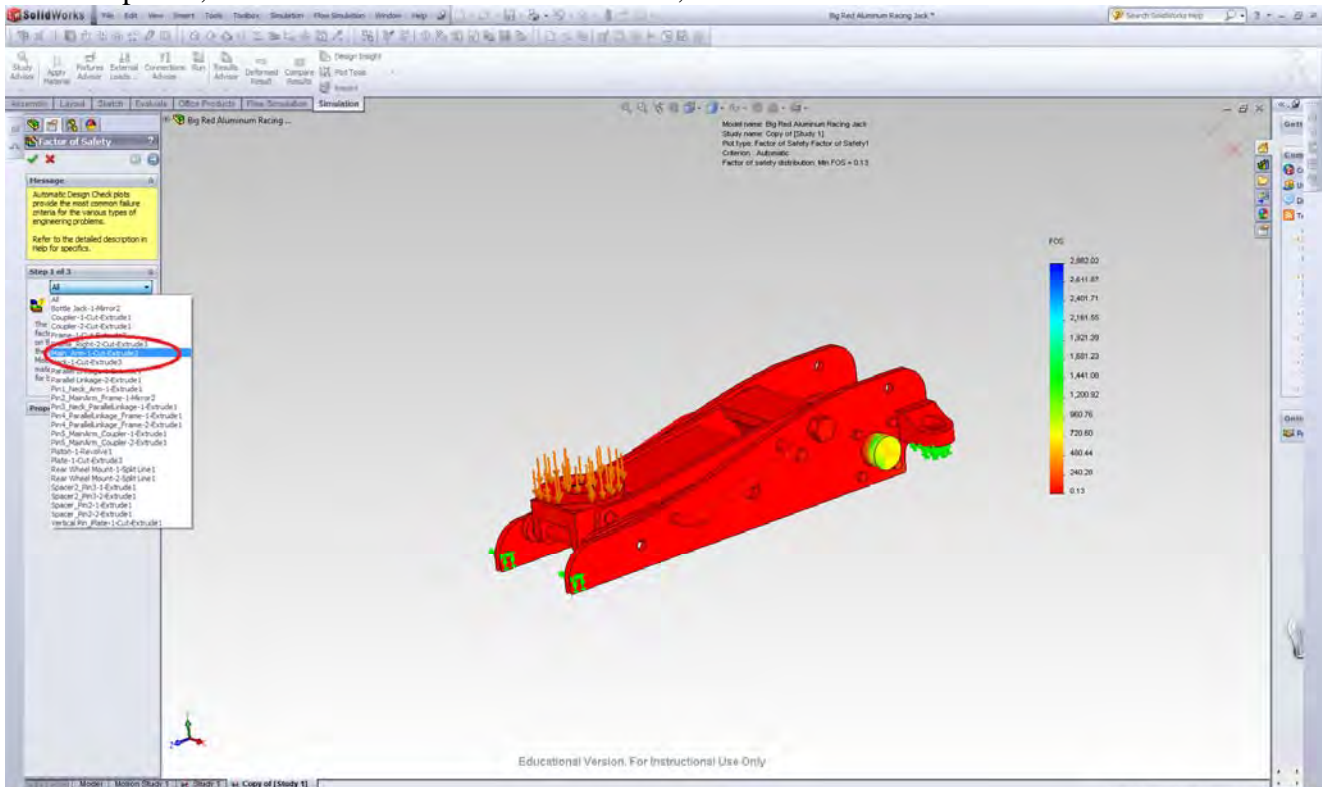

88) The safety factor of the **Main Arm** is plotted

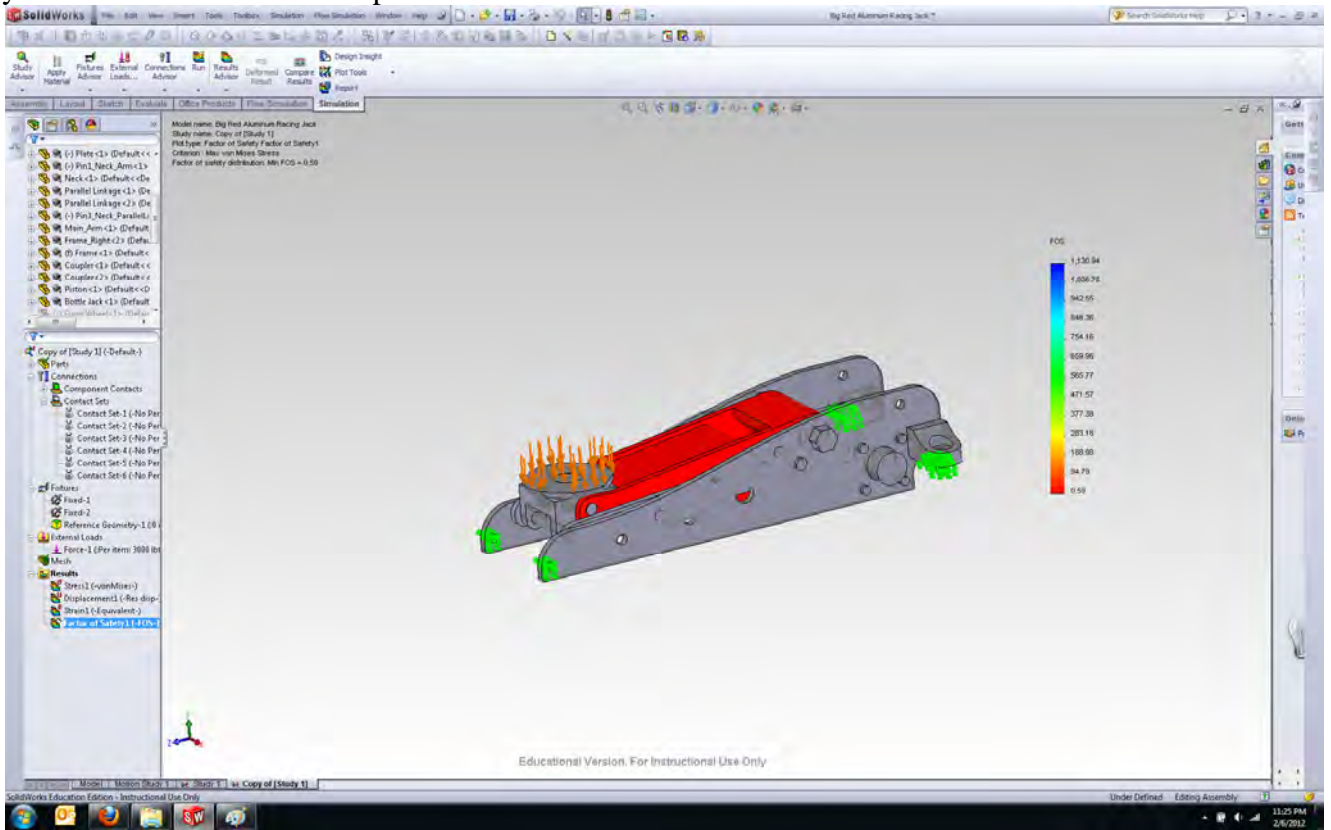

89) This floor jack assembly was modeled with a parameterized function that allows the user to modify the geometry of certain component and having the SolidWorks to automatically change the geometry of the other components associated with the component which its geometry was manually modified. For instance, if you change the diameter of a pin, the hole in which the pin is inserted into is automatically modified with respect to the change in the pin diameter.



90) Now, let us change a radius of **Pin2** to utilize the parameterized function. Right-click **Pin2** and select **Open Part**.

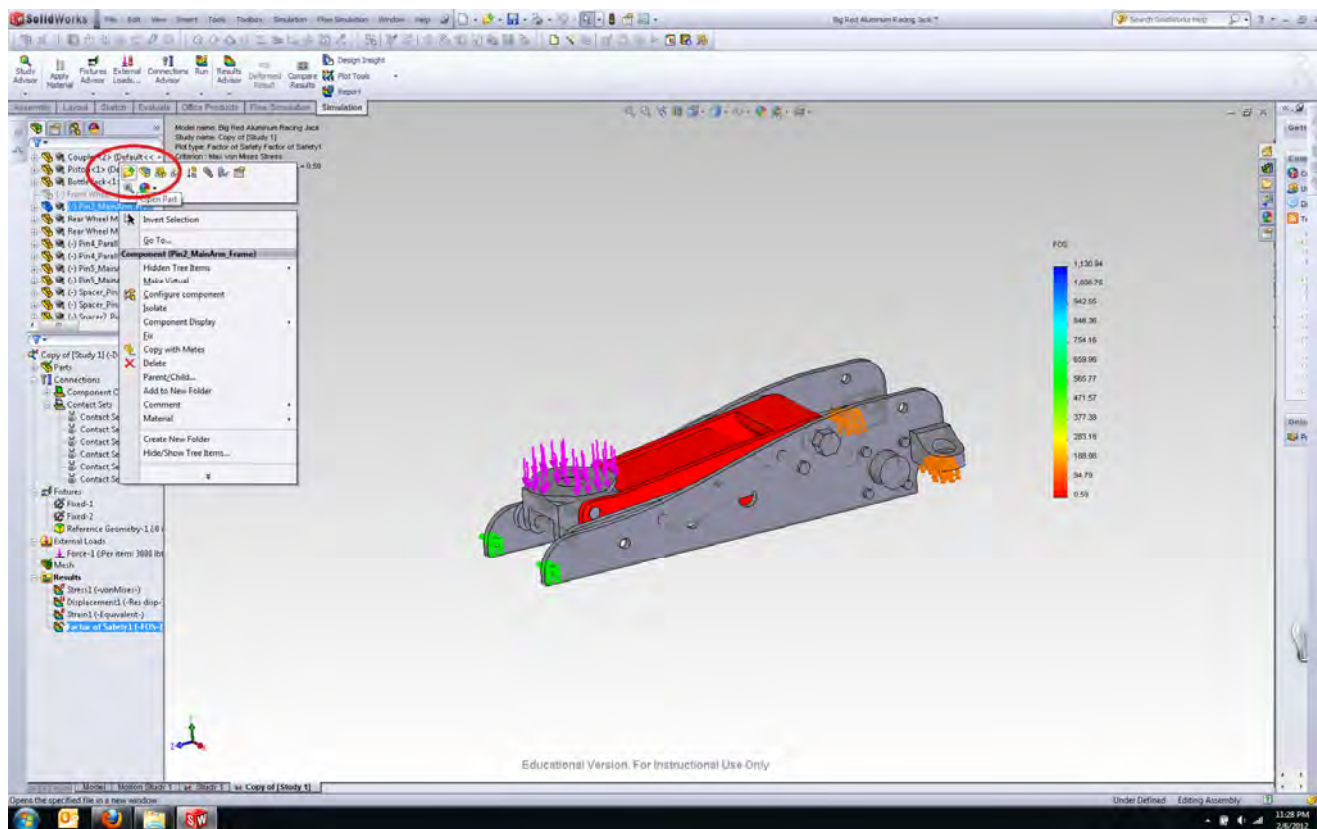

91) **Pin2** now appears on a new window.

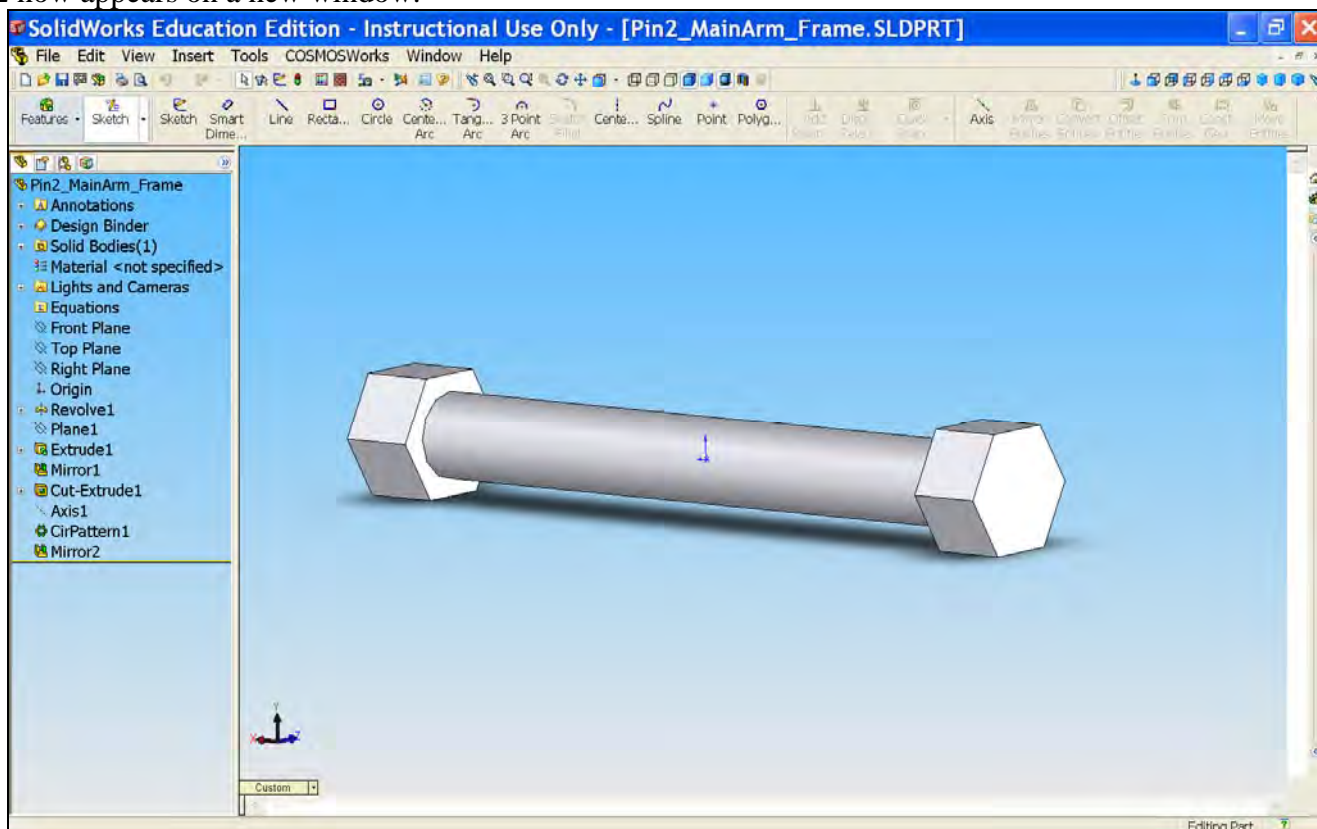

92) Under **Revolve1**, right-click **Sketch1** and select **Show**.

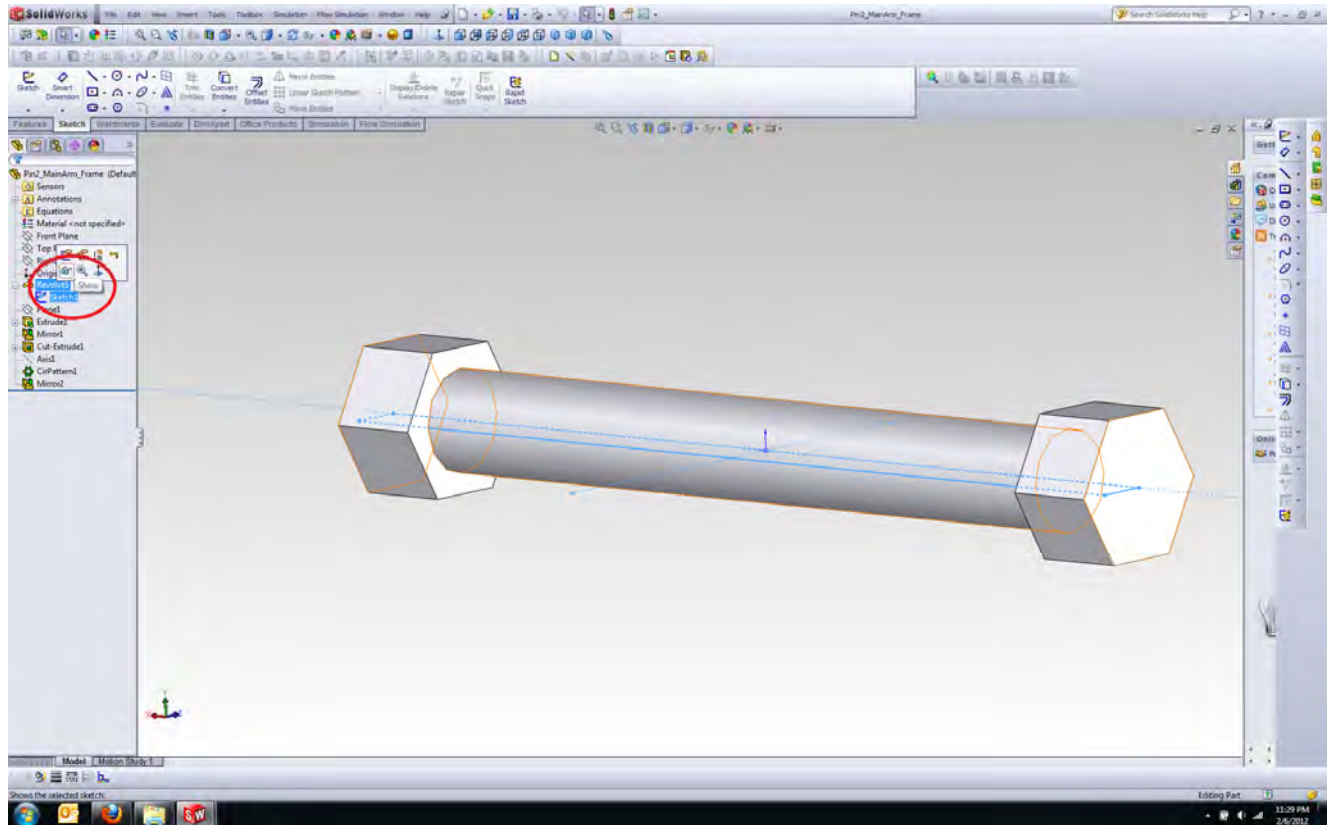

93) Double-click **Sketch1** to view the dimension of **Sketch1**.

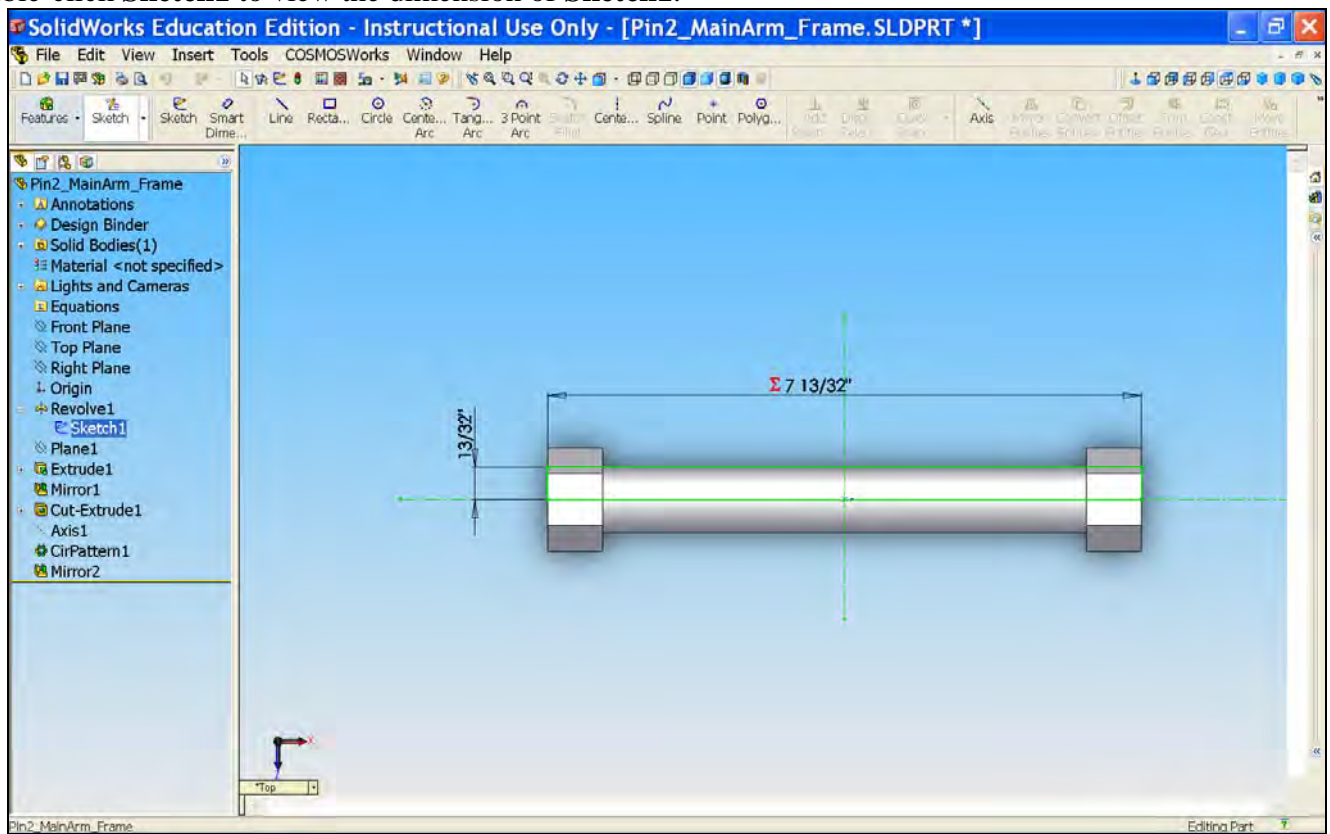



94) Place the mouse pointer on the dimension noted as **D1@Sketch1**. Then, double-click that dimension to modify its value.

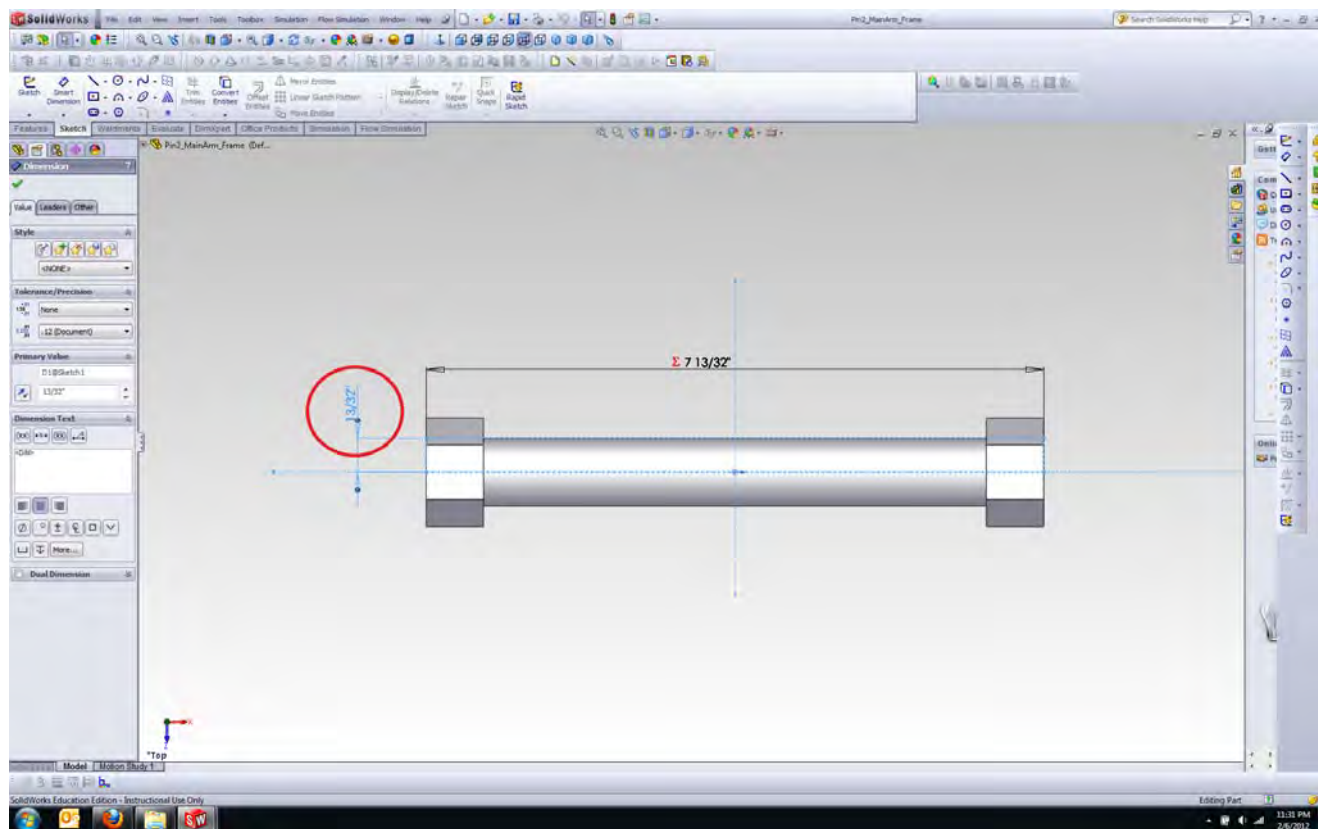

95) The **Modify** box appears. Change the dimension from 13/32" to 1/2".

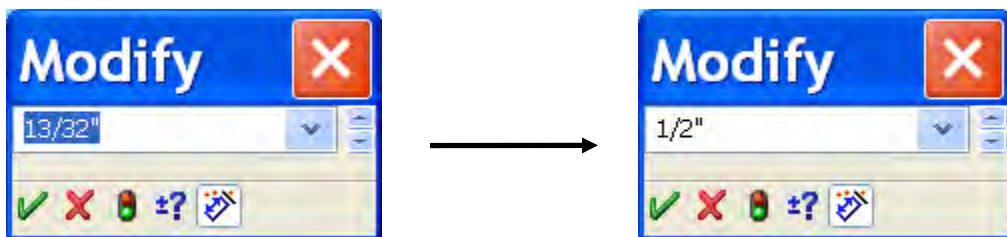

96) Click  **Rebuild** to update the part.

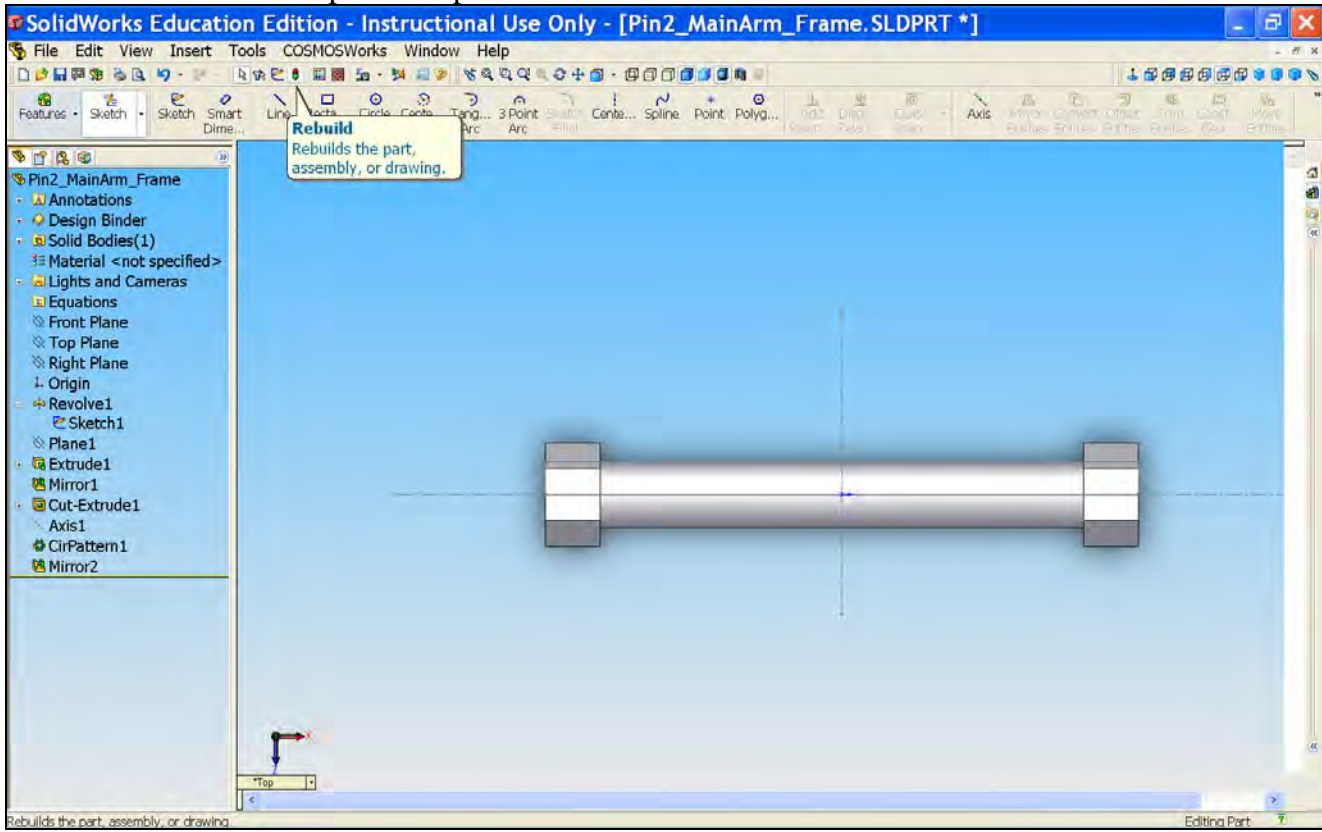

97) Right-click **Sketch1** and select **Hide**.

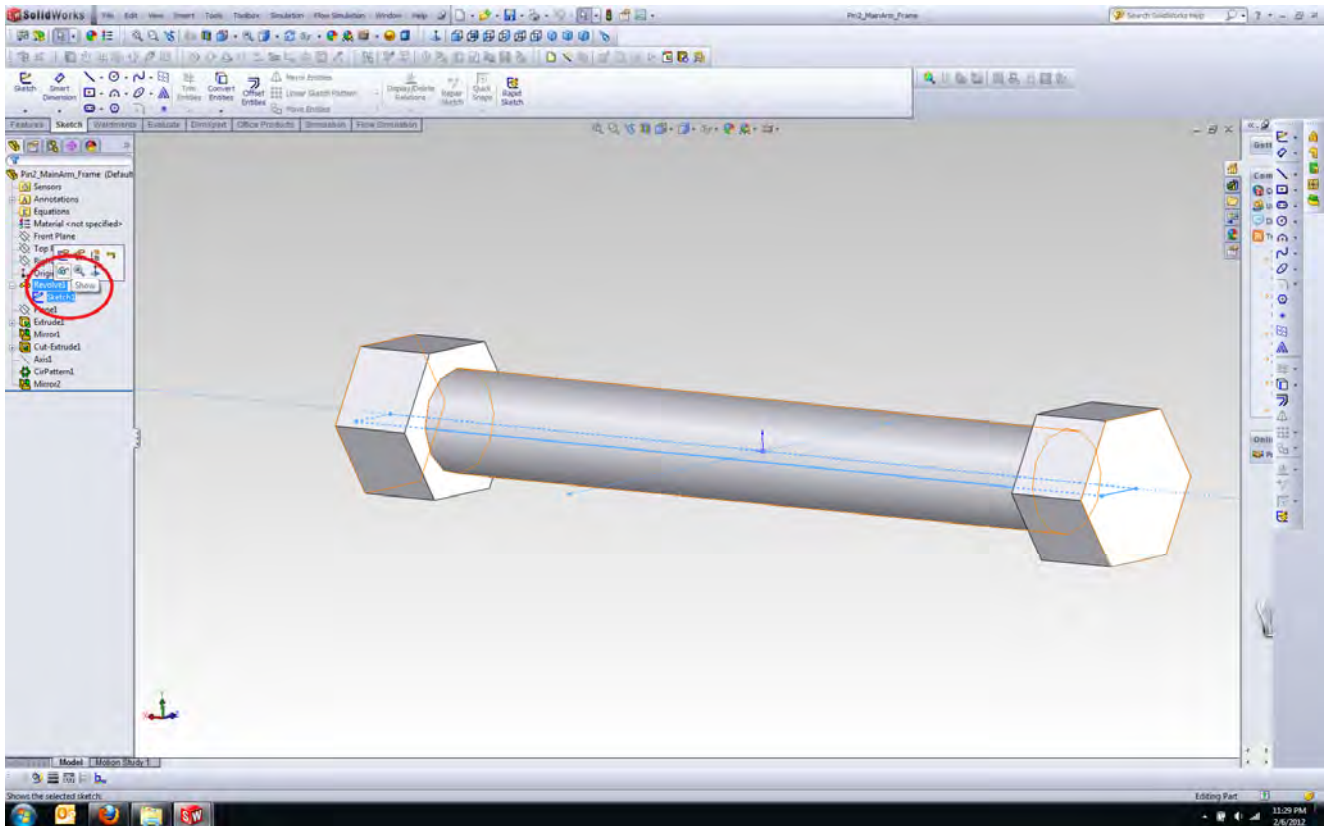



98) Go to **Window** and select **Big Red Aluminum Racing Jack** to go back to the assembly.

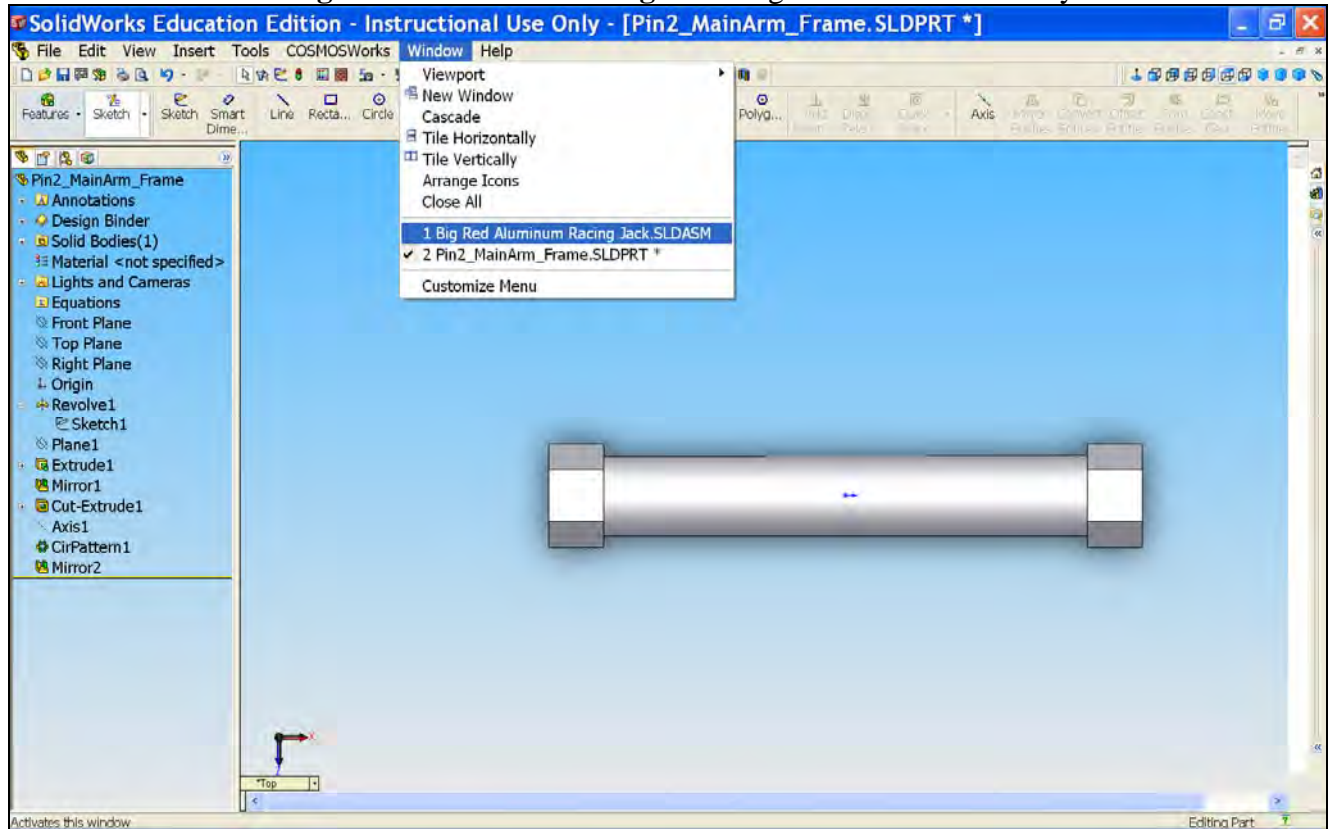

99) Click **Yes** when this window pops up.

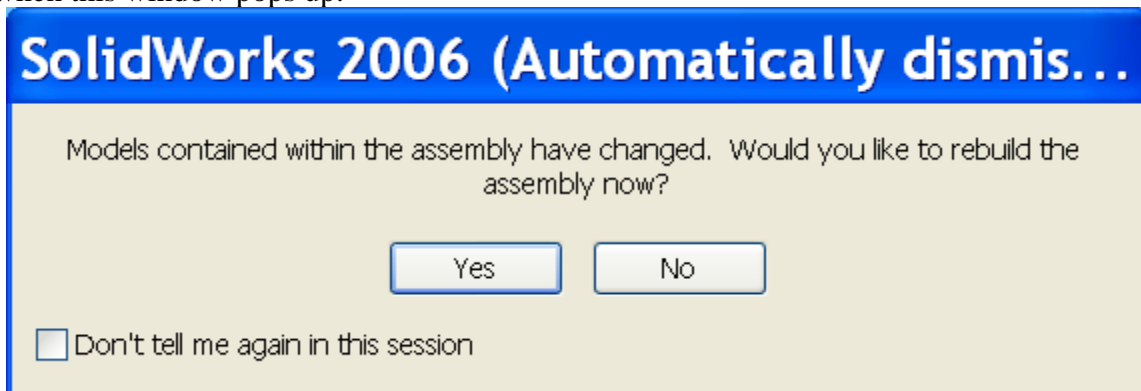

100) Select **Close** when this message prompts.

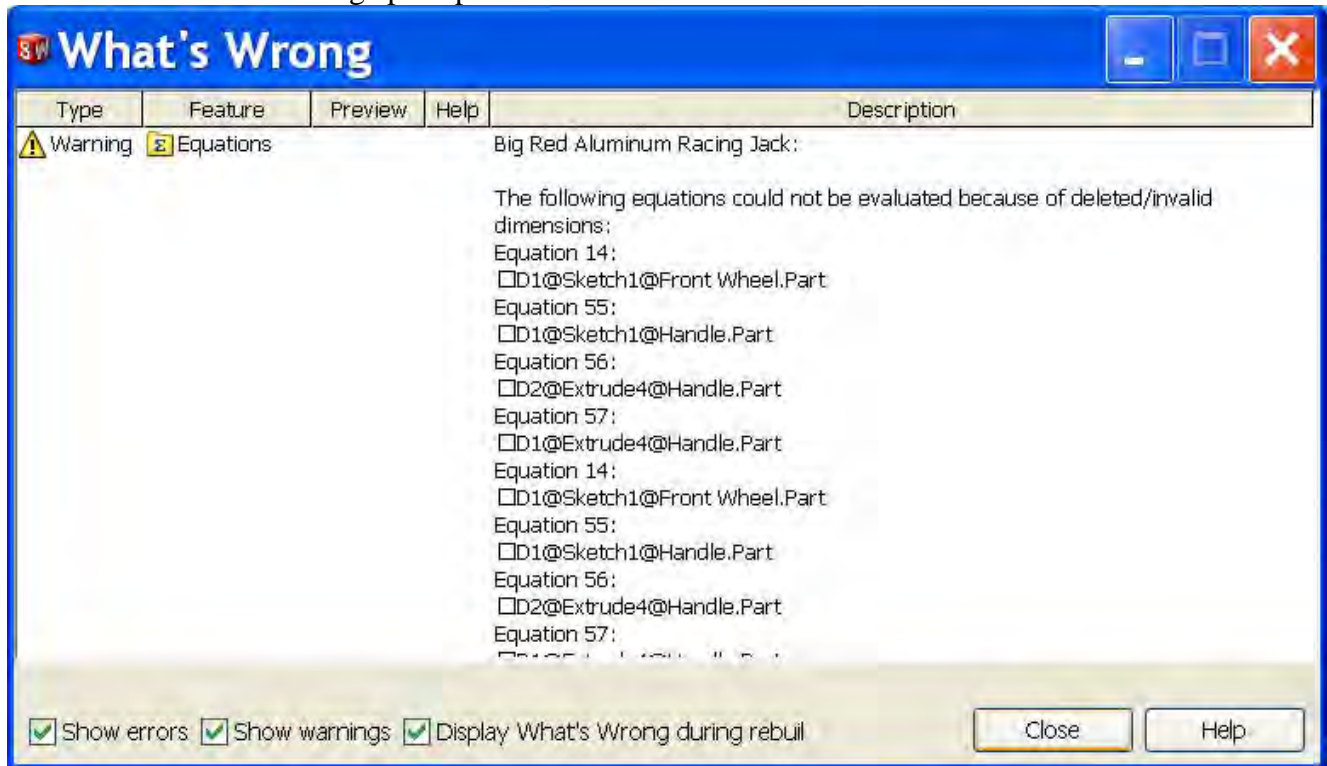

101) Click Study1 tab at bottom to return to study

102) Since the dimension of the **Main Arm** was modified, we need to re-create the mesh to update the SolidWorks results. Right-click **Mesh** and select **CreateMesh**.

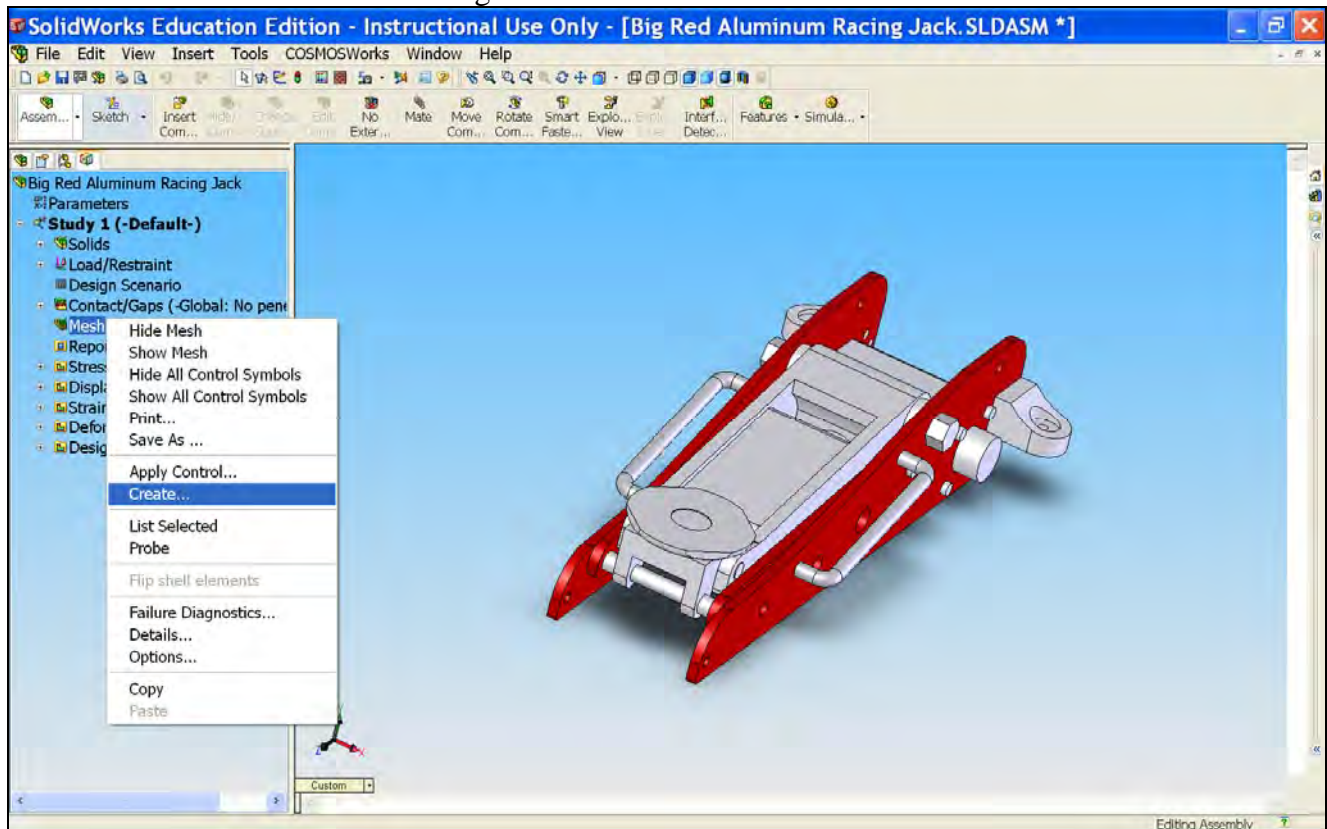



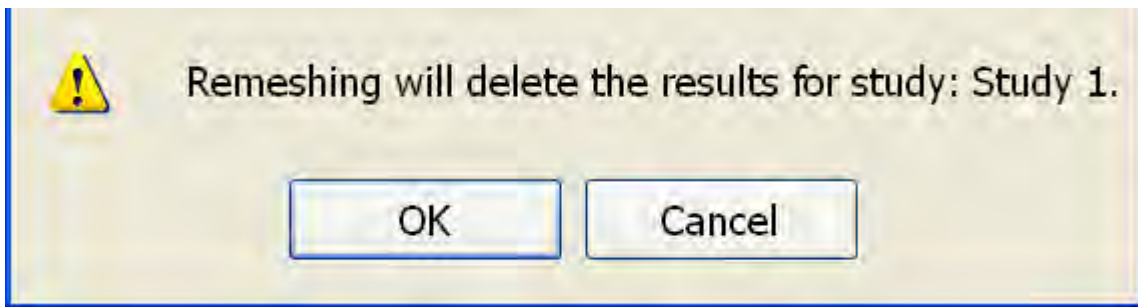

103) Click **OK** to proceed with the default mesh parameters values.

104) **Run** the study

105) When SolidWorks has completed re-running the analysis, double-click **Factory of Safety** to find out how the change in the **Pin2** radius affects the safety factor of **Main Arm**.

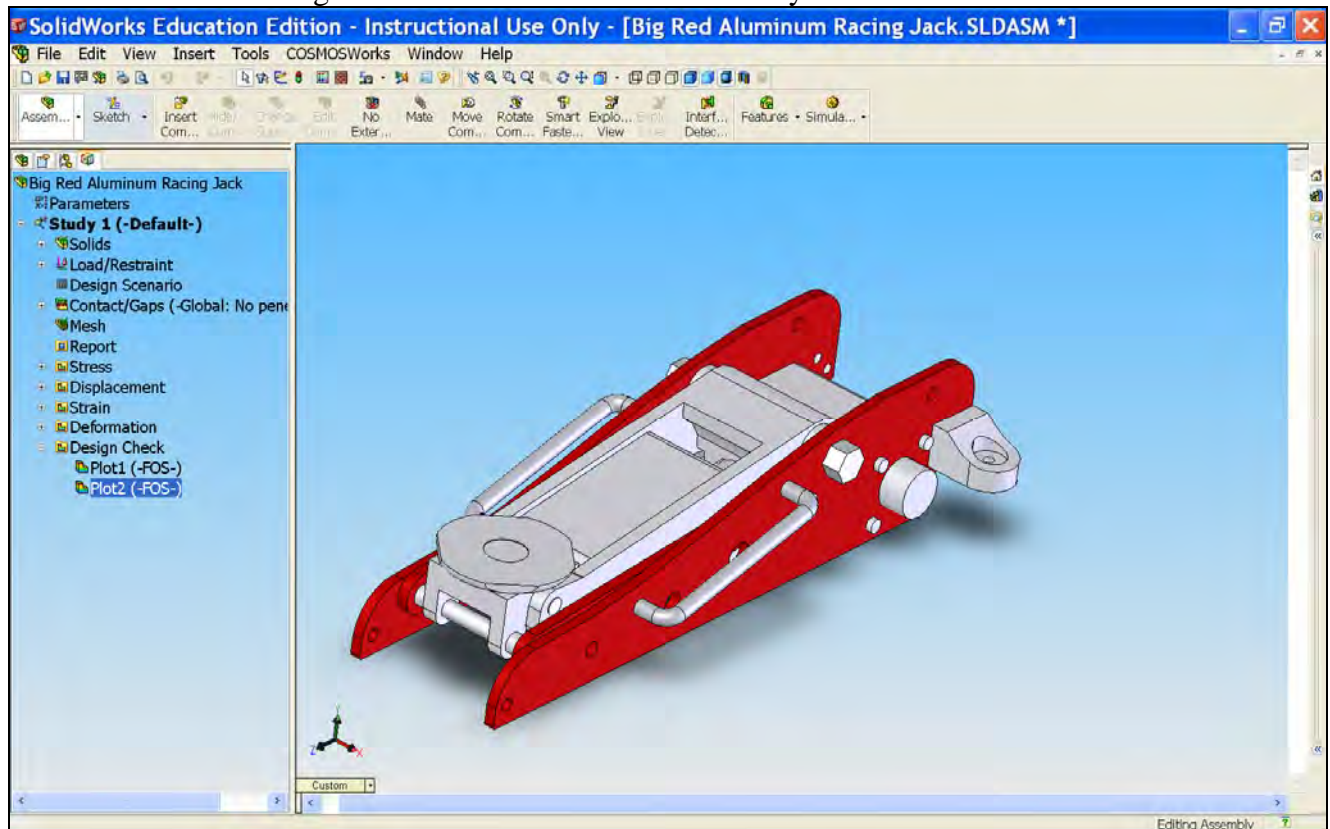

106) According to the manufacturer of this floor jack, this specific floor jack has a maximum lift of 17 ½" (distance from the **Top Plate** to the ground). In this tutorial, we analyzed the stress on the floor jack when the **Top Plate** is supporting a 3000 lb load at floor jack's minimum lift which is 4" from the ground. At its maximum lift (17 ½"), the stress throughout the floor jack will be different in comparison to its stress at its minimum lift (4"). To find out how the lift height affects the stress throughout the floor jack, you can perform the stress analysis on your own by simply changing the distance between the **Top Plate** and the **Top Plane** as discussed in **Step 7** of this tutorial. You will then need to re-create the mesh and re-run the analysis to update the SolidWorks results.