

ME345 Modeling and Simulation, Fall 2018

Case Study 2

Assigned: Friday November 2, 2018

Due: Tuesday November 27 (by 11:59pm on CANVAS)

Note 1: You are **STRONGLY** encouraged to complete the assignment prior to this due date!

Note 2: Each of the Case Studies will be done in groups of 3 students. Each student is expected to contribute equally to the group work. No two students can sign up to be in the same group for more than one Case Study (as discussed in class). Students will be asked to complete an anonymous Group Member evaluation after submitting the Case Study assignment.

Note 3: One report per group should be submitted through CANVAS by the deadline indicated above. All team members are responsible for all aspects of the project work.

PROBLEM 1. (30% of grade)

In a manufacturing process, a transparent film is being bonded to a substrate as shown in Figure 1 below. To cure the bond at a temperature T_0 , a radiant source is used to provide a heat flux q_0'' (W/m^2), all of which is absorbed at the bonded surface. The back of the substrate is maintained at a constant temperature T_1 while the free surface of the film is exposed to air at T_{inf} and a convection coefficient h . Assume the following conditions: $T_{\text{inf}} = 20^\circ\text{C}$, $h = 50 \text{ W}/\text{m}^2 \text{ K}$, and $T_1 = 30^\circ\text{C}$. Find the heat flux q_0'' (W/m^2) that is required to maintain a bonded surface temperature of $T_0 = 80^\circ\text{C}$. (Suggestion: to some extent you can set up the work on the Parts below separately; be efficient in the use of your group's time and resources.)

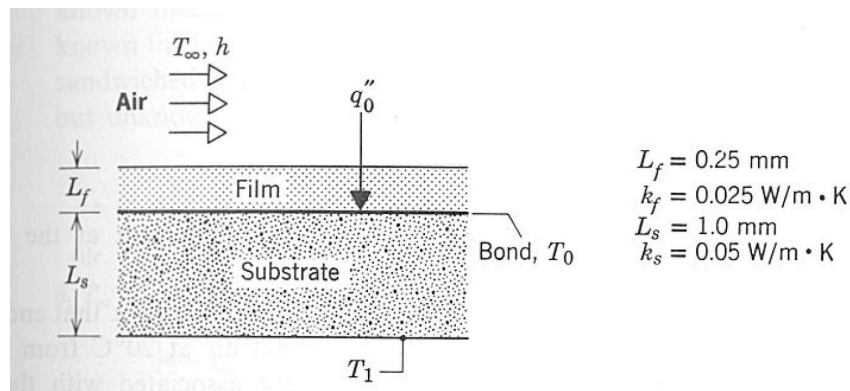

Figure 1. Schematic of manufacturing process for Problem 1.

Part A. We can model this as a one-dimensional heat transfer problem. Using just 1D convection and conduction finite elements, draw the equivalent circuit by hand. Using the finite element analysis approach by hand demonstrated in lecture, derive the global stiffness matrix with the known temperatures and external applied heat fluxes shown in matrix form.

Hint 1: the problem has three elements in this case: convection at the top surface, conduction through the film, and conduction through the substrate. Be careful when considering units.

Hint 2: if you re-number the nodes from top to bottom, node 1 has a temperature of T_{inf} and an unknown heat flux, T_2 has an unknown temperature and zero external applied heat flux (all heat flux is assumed to be applied at node 3), T_3 has a desired temperature of 80 °C and the necessary external applied heat flux (this is an unknown that you are trying to calculate), and T_4 is the known temperature labeled T_1 above with unknown external applied heat flux; hence you should have 4 equations and 4 unknowns.

Part B. Using your favorite math tool, solve the system of four equations and four unknowns to determine the necessary heat flux q_0'' (W/m²) to maintain a temperature of 80 °C at the bonded surface.

Part C. The objective is now to compare your analytical solution with a three-dimensional CAE analysis. Using the heat flux q_0'' (W/m²) found in Part B for all cases, conduct a DESIGN SCENARIO where the lateral dimensions of the square film (in mm) are 5, 10, 15, 20, 25, and 30mm on a side. Assume that the same convection conditions at the top of the film are also present on all sides of the film. In your report describe:

C1. In a little detail, the specifics of how you set up the DESIGN SCENARIO in SolidWorks Simulation. (I am specifically looking for you to describe how you automated the process; while you can check all cases by hand if you wish, it is not enough to run individual analyzes for each analysis; I am specifically asking for the Design Scenario tool to be used.)

C2. In your report, discuss the sensibility of your results in terms of how changing the lateral dimensions of the film and substrate alter the temperatures that you found.

PROBLEM 2. (40% of grade)

Note: In class we have discussed several 1D finite elements. In this problem you will be asked to apply this knowledge to tackle a 2D truss problem. Further description of the 2D truss element and an example problem are provided in the class notes here (although not explicitly covered in class): http://personal.stevens.edu/~ffisher/me345/Intro_FEM_notes1.pdf

The element stiffness matrix for a 2D truss in global coordinates is given as

$$\begin{Bmatrix} f_{xI} \\ f_{yI} \\ f_{xJ} \\ f_{yJ} \end{Bmatrix} = \frac{AE}{L} \begin{bmatrix} c^2 & cs & -c^2 & -cs \\ cs & s^2 & -cs & -s^2 \\ -c^2 & -cs & c^2 & cs \\ -cs & -s^2 & cs & s^2 \end{bmatrix} \begin{Bmatrix} d_{xI} \\ d_{yI} \\ d_{xJ} \\ d_{yJ} \end{Bmatrix}$$

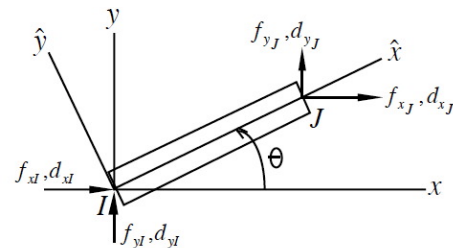

where $c = \cos \theta$ and $s = \sin \theta$, and A , E , and L are the cross-sectional area, modulus, and length of the element.

For the truss element shown in Figure 2, assume that the elements are made of aluminum ($E = 70$ GPa) with a cross-sectional area of 0.005 m². Assume a yield strength of 55 MPa for all elements.

Part A: Using the definition of the 2D truss element presented above, determine the deflections of points B, C, and D in the truss by implementing the finite element approach 'by hand'. (Please use a calculator to perform any matrix calculations.) Be sure to report the global stiffness and how it was assembled.

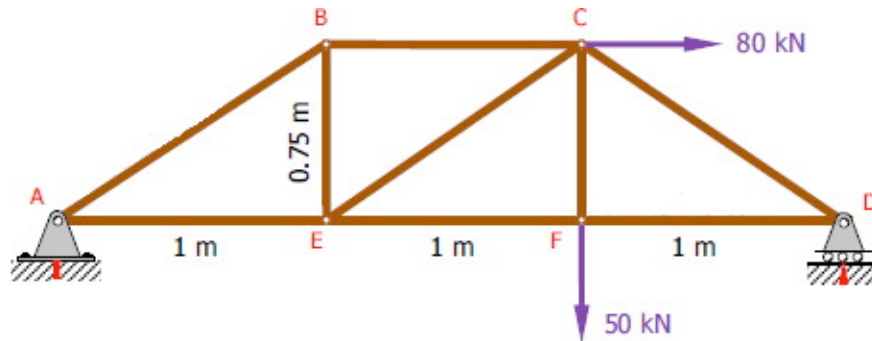

Figure 2. Truss problem for analysis in Problem 2.

Part B: To confirm your analysis, use a CAE package of your choice to determine the nodal displacements of points B, C, E, and F. Be sure to compare your results to the values obtained from Part A. Be sure to also report the stresses found for each element. For two elements of your choosing, report the stresses you calculated by hand and the stresses found via the CAE package.

Part C: For three elements (of your choosing), use either the Method of Joints or the Method of Sections to determine the internal forces in the element. Compare this result to forces found in Part B. (Note it will be necessary to use the relationship between forces and stresses in this comparison.)

PROBLEM 3. (30% of grade)

A rectangular alloy steel plate with two holes is subject to a 25,000N tensile load as shown in Figure 3. You are asked to run a **Design Optimization** in SolidWorks Simulation to determine if the plate can be made lighter (i.e. the holes made larger). As shown in Figure 3 below, in the initial size of the plate is 50mm in height, 120 mm in length, and 5 mm in thickness.

Part A. Select and justify an appropriate Safety Factor to be used in the analysis. You may assume that the loads and environmental conditions in which the part will be operated are generally understood, and that the part will have infrequent (if any) inspections.

Part B. For the given geometry and conditions Figure 3, determine the maximum stress in the plate. *Quantitatively* discuss the sensitivity of your results to the size of your mesh with examples (specifically, conduct a simulation with different mesh densities and describe how this impacts your results). Discuss your results.

Part C. Now perform a design optimization on the plate which maintains the outer dimensions of the plate but allows the diameters of the holes in the plate to change, with the goal of minimizing the weight of the structure. The diameters of the holes can be different. The maximum possible diameters of the holes are

assumed to be 40 mm. Minimize the weight of the plate while ensuring that the von Mises stresses are less than the yield stress. Be sure to discuss:

- in some detail, how you conducted the design optimization
- the values of the weight pre- and post-optimization
- the impact of a Factor of Safety on your analysis (illustrate using a realistic example)

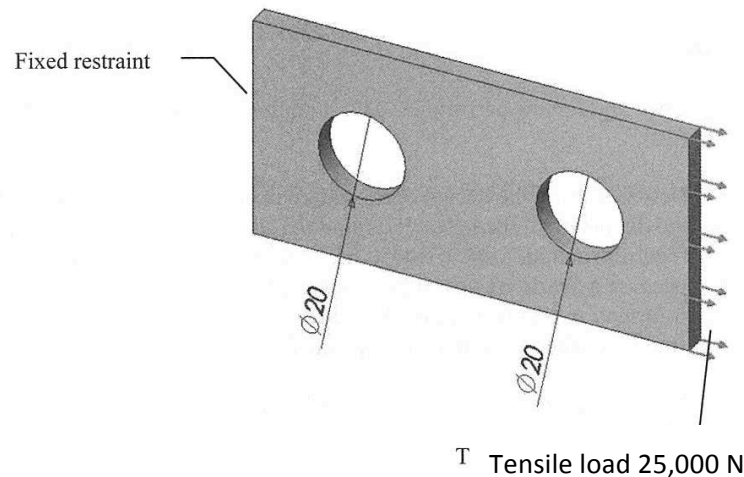

Fig. 3. Initial geometry for Design Optimization study. With the origin at (0,0), the center of the left hole is (30, 25); the right hole is mirrored about the centerline of the plate.

Part D. It has been suggested that an alternative manner to reduce the weight of the plate is to change the material. You have been asked to consider two materials: a high performance aluminum and a light weight, high performance polymer (plastic). For each of these materials, conduct an analysis similar to the one above to determine the whether these materials will work and, if so, determine an optimal size of the holes for each material. (Note: Do you really want to limit your choices to a small number of materials in a given software database?)

Report:

Your group will need to submit an engineering report of your analysis to the company president (i.e. the professor). The report should be **well-organized, clear, and concise**, and at minimum address the points listed above. The report should also provide a justification of why the results that you have obtained are sensible. **NOTE: just submitting the software output without your analysis and discussion is NOT acceptable. EACH PROBLEM SHOULD BE WRITTEN AS A SEPARATE 'CHAPTER', BUT SUBMITTED AS A SINGLE REPORT.** While it is natural to discuss your work and progress with your colleagues (i.e. classmates), **individual group analyzes and reports are required [this cannot be emphasized enough – work that fails to meet this requirement will not be given credit for the assignment]**. Your supervisor (i.e. the TA) is also available to answer thoughtful questions as you work on the project, but it would be unprofessional to overly rely on your supervisor to complete your project.