

Modeling and Simulation

Tutorial 1. (Four Bars Mechanism)

Objective: To create a simple mechanism in Cosmos Motion.

Elements to use: Solid Works
Cosmos Motion
Dynamics Books

Description: This tutorial introduces Students to Cosmos Motion Software, which is embedded in Solid Works. A simple four bars mechanism will be used as example. Student will create the solid models by using Solid Works and later they will use cosmos motion to animate and calculate the absolute velocities on different points of these.

Cosmos Motion: This software is useful to study the behavior of Solid Works assemblies in motion, so that the designer can detect any design problems before building hardware prototypes. This software simulates the mechanical operations of motorized assemblies and the physical forces they generate

This software can perform the following calculations:

- Detect interferences between parts.
- Show forces and effects of collisions between parts.
- Output force data to Cosmos Works FEA Package for structural analysis.
- Use XY plots to graph quantities.
- Animate motion on screen in wireframe, hidden-lines removed or rendered display, and store as AVI or VRML files.

Creation of Linking Bars

Attached to this tutorial, students will find some drawings, which have been created with SolidWorks. Students are supposed to know how to use this CAD software and obviously create 3D models, so that the drawings supplied will help students to create the necessary 3D models to create the SolidWorks Assembly.

Creation of Solid Works Assembly

Create a new assembly in SolidWorks , browse for the part called support, open it twice

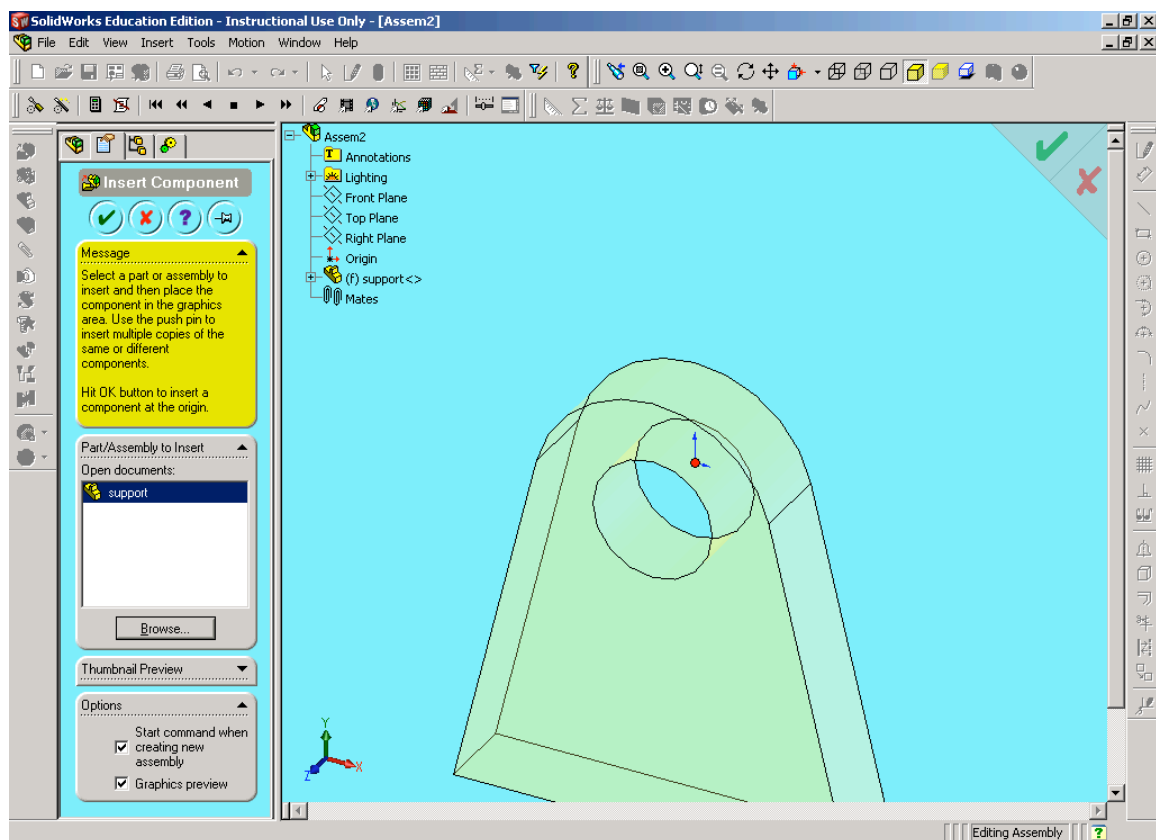

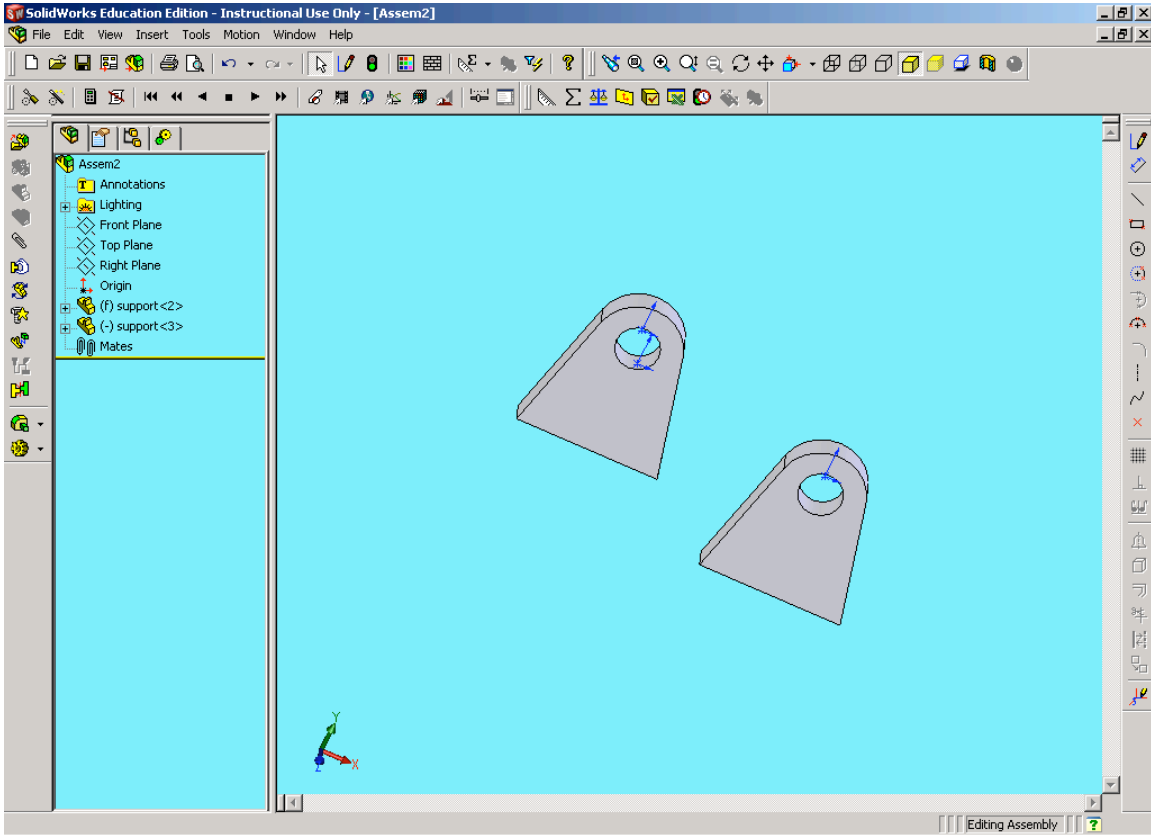

Now, it is necessary to create constraints (mates) for this two parts, the constraints will be the distance between the pieces and the coincidence between the front and lower faces of these, when the constraints are being created, a dialog box appears, it suggests to automatically add the parts to grounding or moving parts, if yes is selected, the software automatically add the motion constraints to the parts and probably these has to be changed later, if no , then the constraints have to be created manually.

Select No

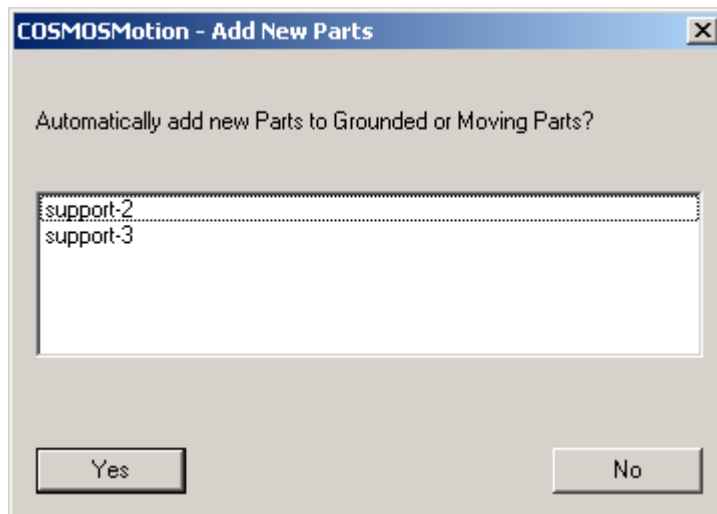

Select the front faces and click on the coincident button

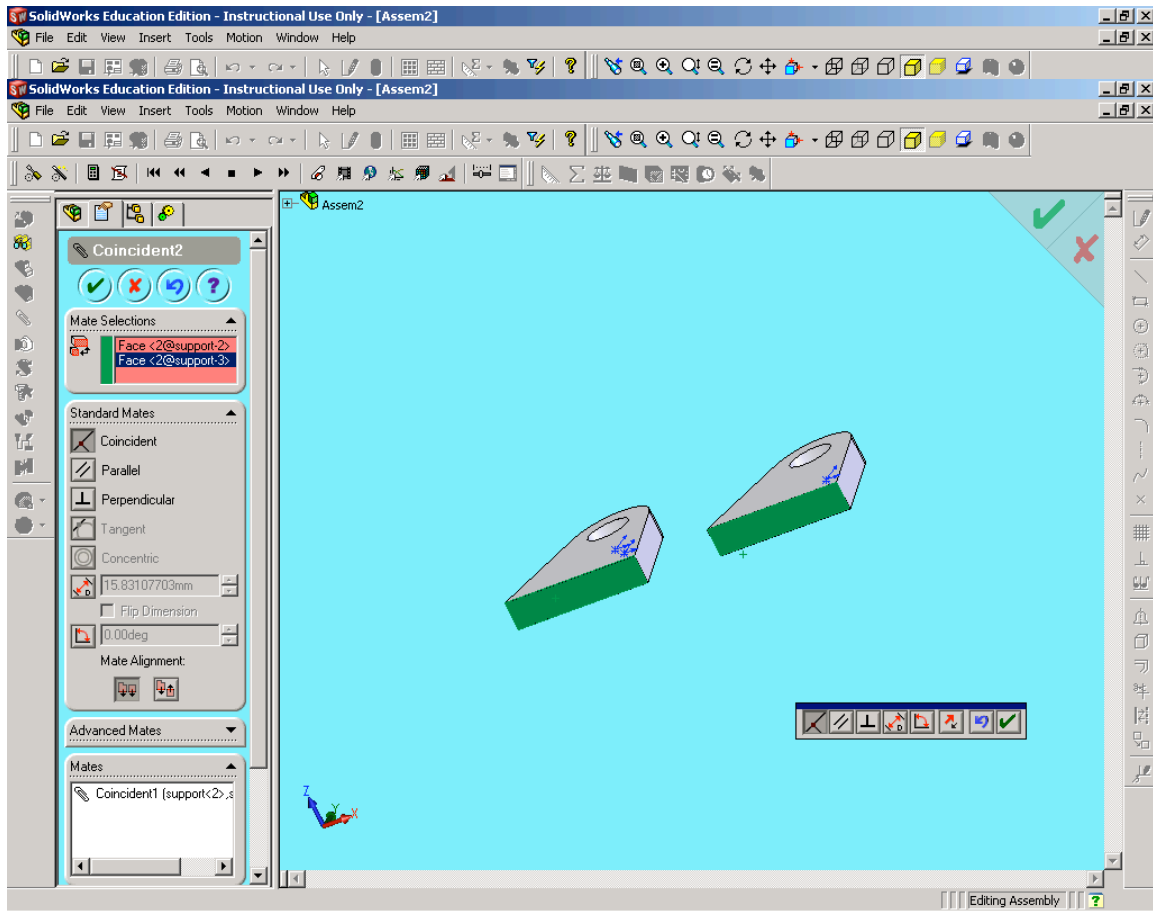

Now, click on the lowest faces (bottom) and select coincident again

Select the lowest internal edge of every element, and set a distance of 8 inches

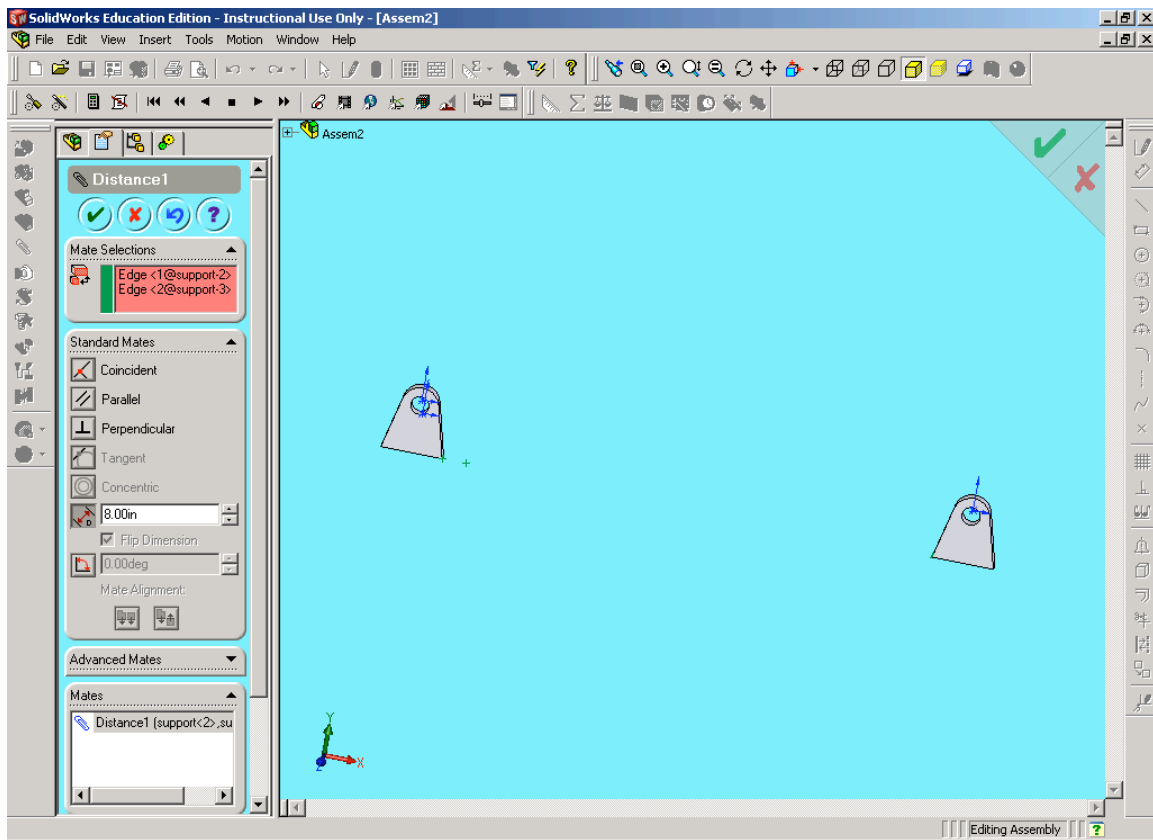

The parts 1, 2 and 3 will be assembled in their respectively position, the necessary constraints to create the mechanism are:

- Coincident
- Concentric

If a distance between two linkages is set, then the distance constraint has to be used. In this case none distance constraint is used.

Open part 1, and place it close to the support on the left

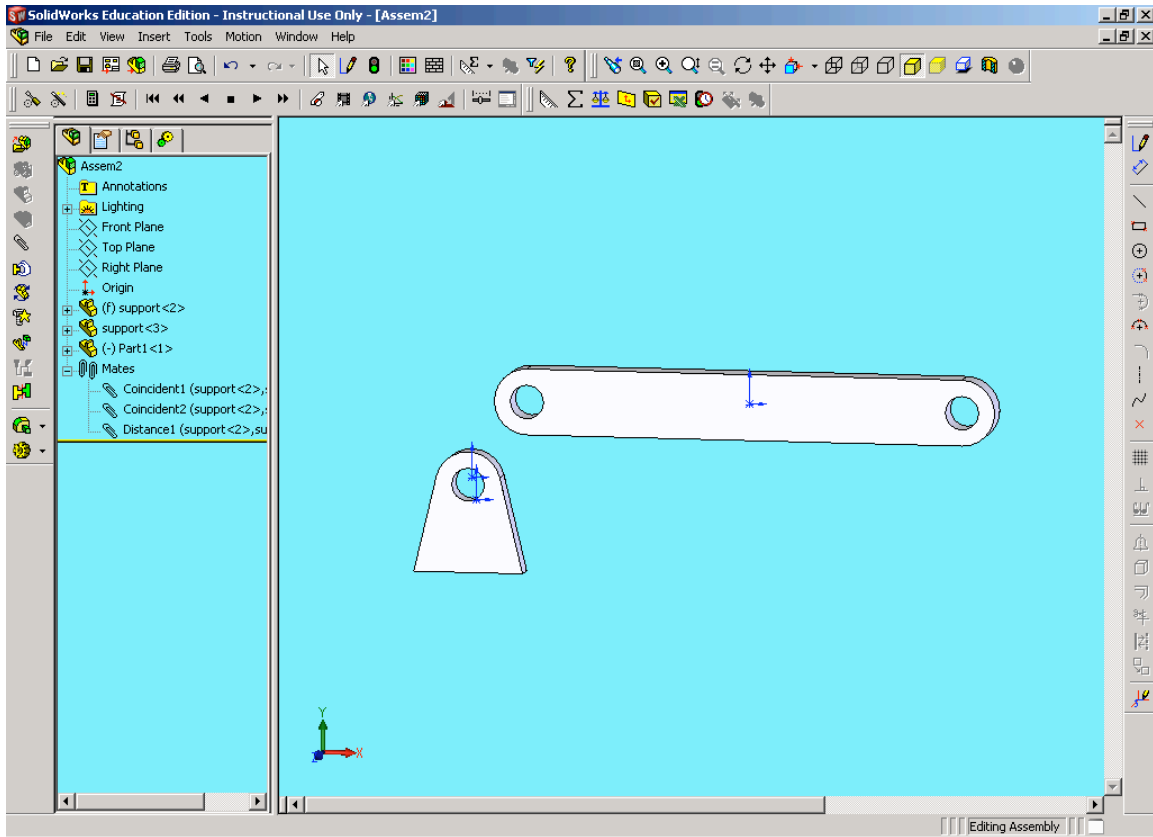

Select the opposite face of the support part (keeping the above graphic as reference), and the front face of the bar, and click on the coincident button.

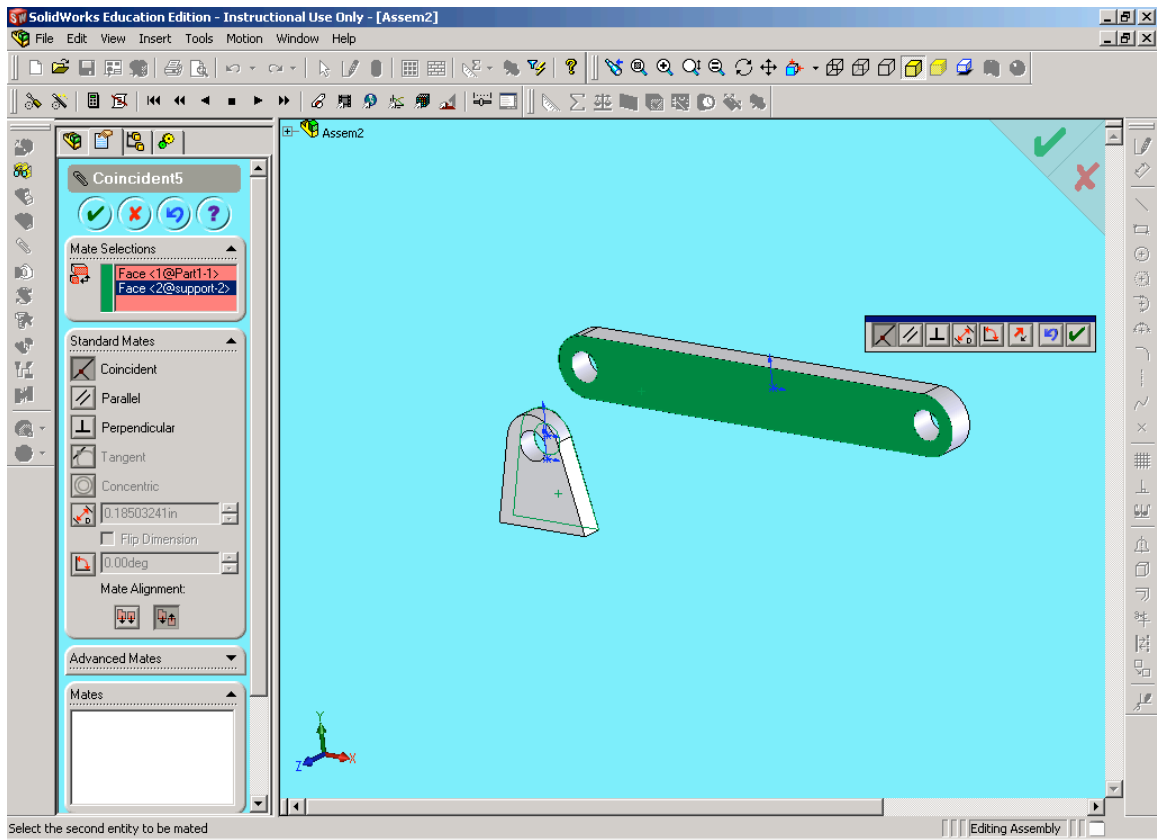

Now, select the internal faces of the holes (the bar and support), and select the concentric button, click the move component button and select the bar and move it to the best position to assembly the next one

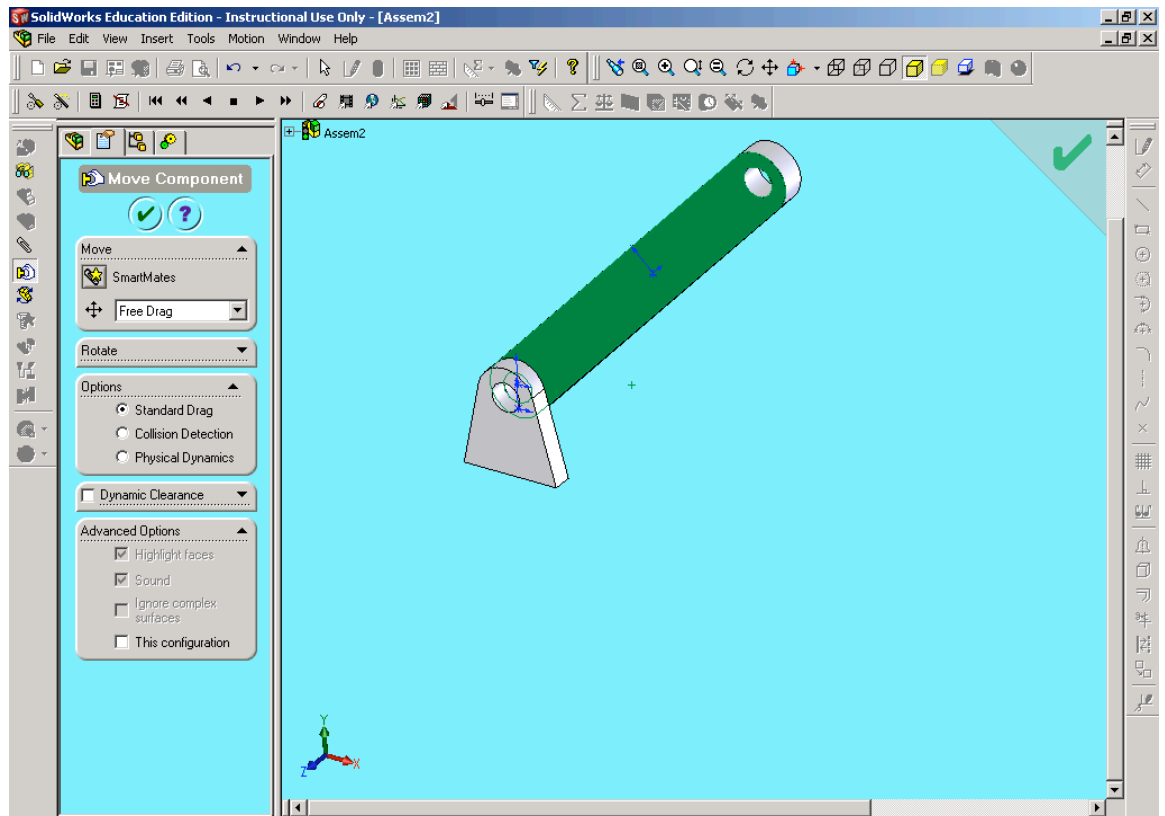

Repeat this procedure with the parts two and three, remember to click on **No** every time the add new part dialog box appears.

For the part two, select the back face and for the part one select the front face

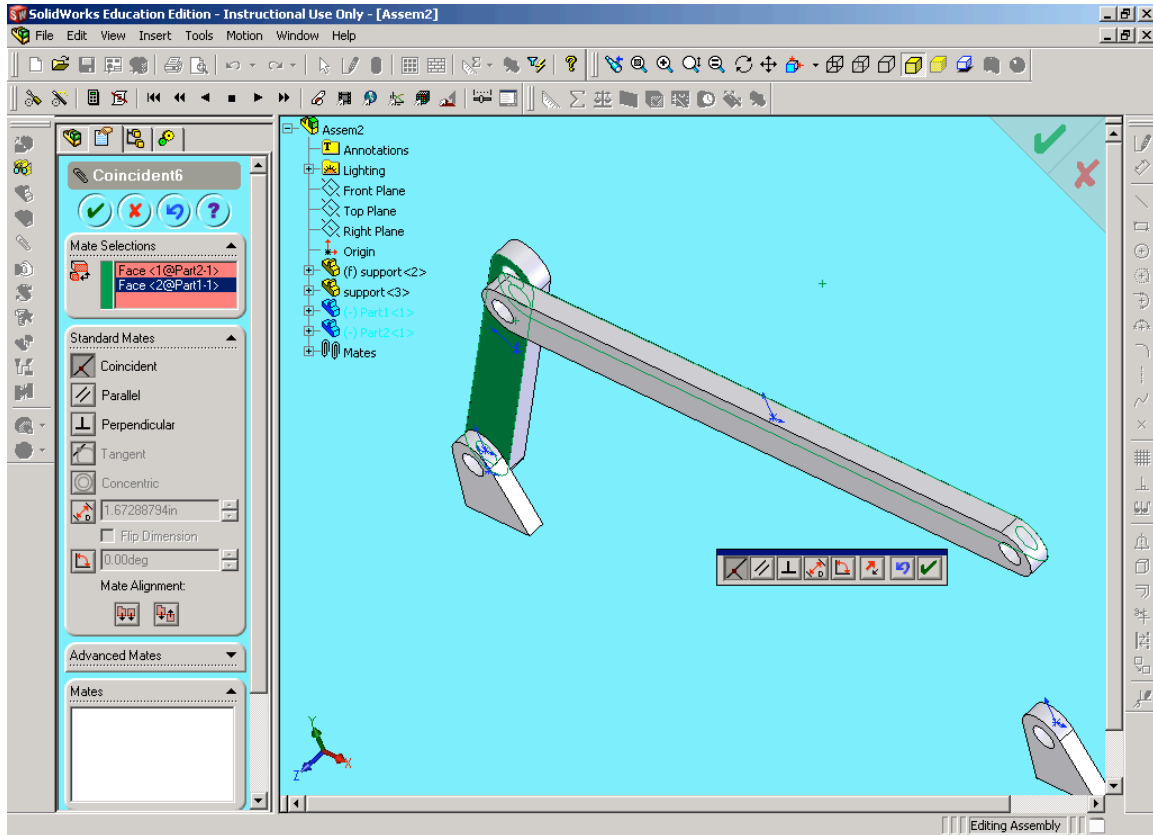

For the assembly of the part three select the same faces, use the move button to move the bars to find good position to assembly.

For the third part, select the front face of this, and the back face of the second part

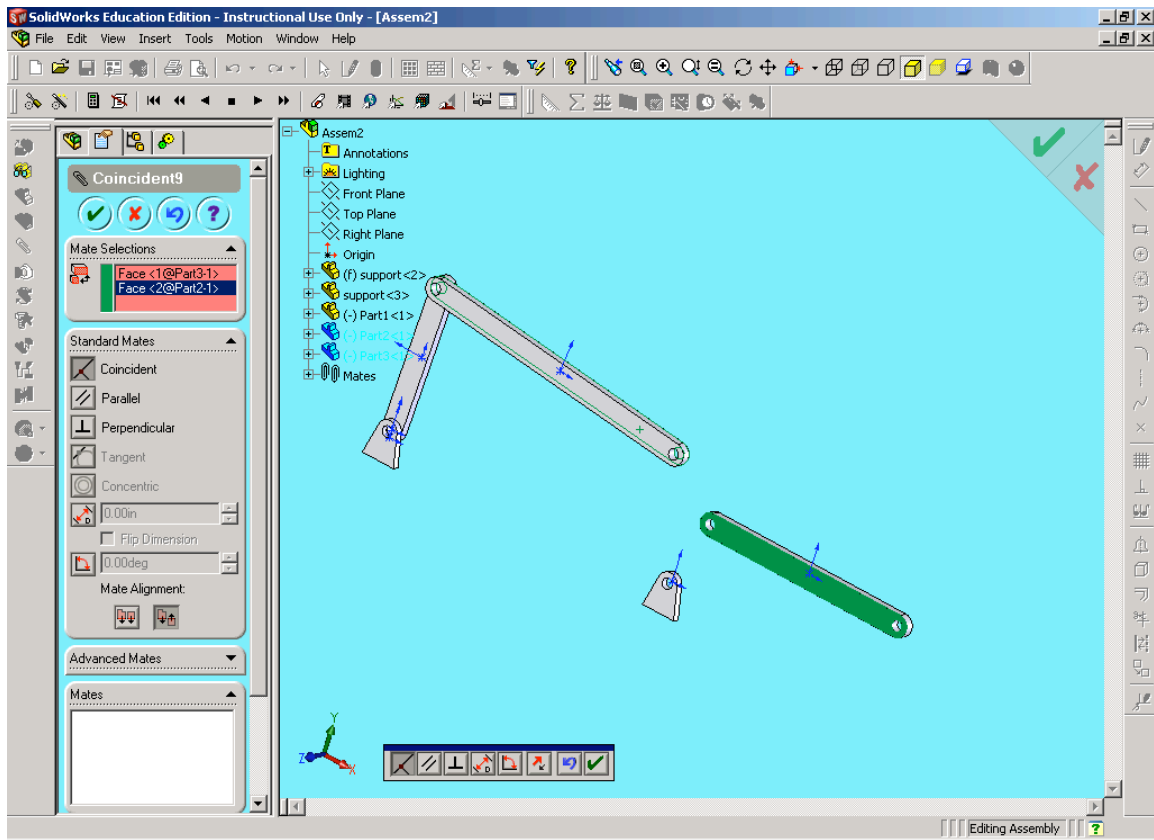

Select the internal faces of coincident holes and click concentric, repeat the procedure for the constraints between the third bar and the second support.

The mechanism should look such as the following picture:

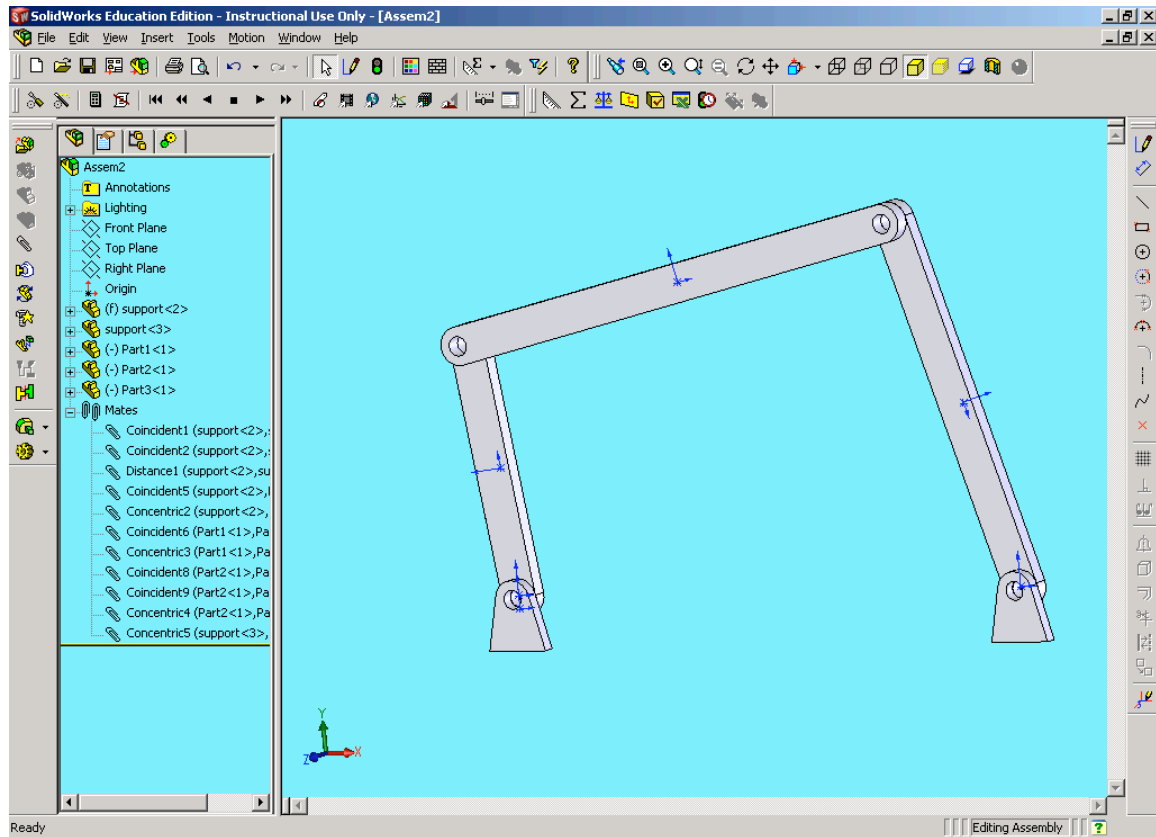

Click on the motion button in the windows manager of SolidWorks

Click on Support 2, and drag this part into the ground parts branch, repeat the procedure with Support 3, drag the parts 1, 2 and 3 into the moving parts branch in the motion manager tree.

Automatically the software will assume some motion constraints according the assembly mate constraints that have been created. These motion constraints have to be checked.

Now, click on the move button and (select) move the Part1, the mechanism works, it indicates that the motion constraints are correct.

Click on the Joints constraints, and right click on the revolute that was created between the support (1) and the Part1, click on properties

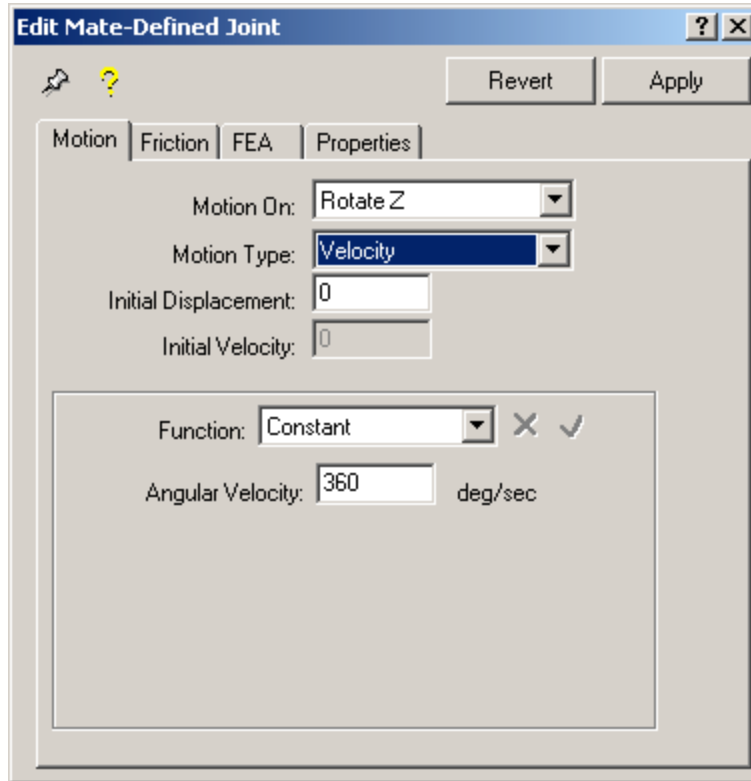

Select an angular velocity of 360 deg/sec (Constant), and motion on Z, click apply
(Use a -360 deg/sec and see what happens)

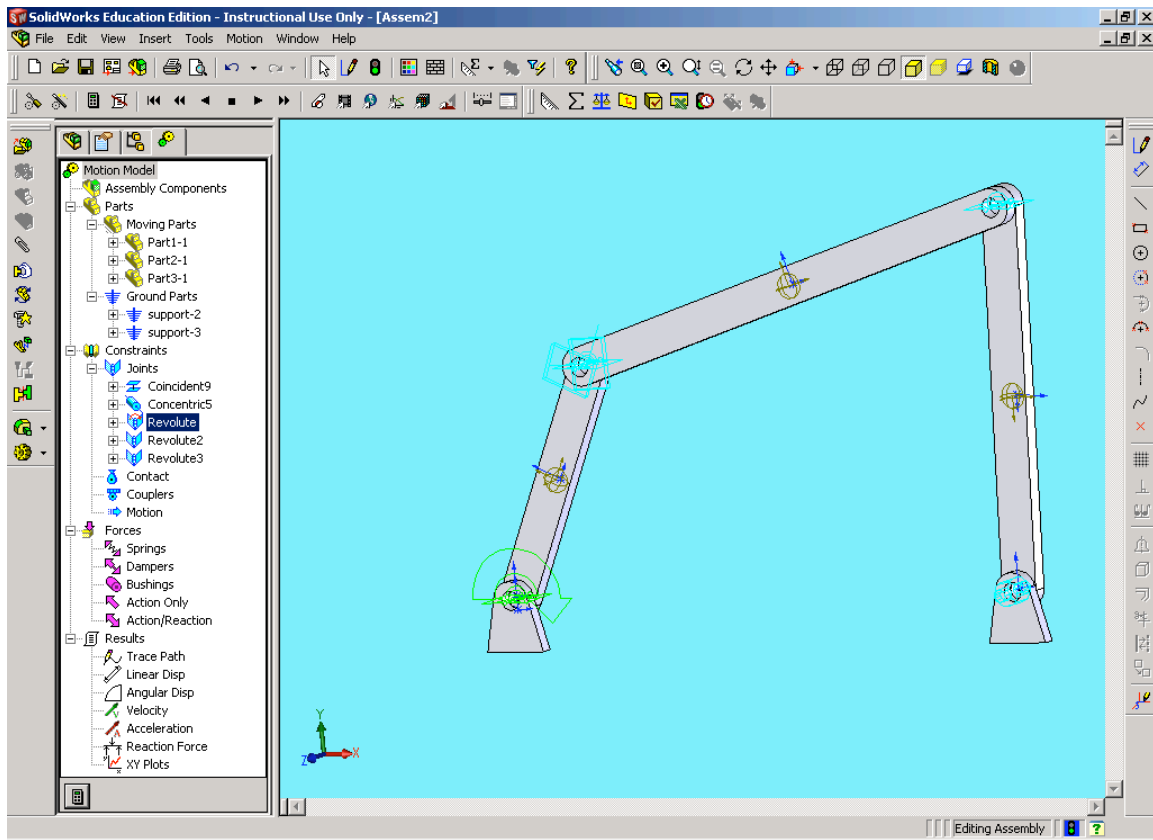

Go to **Motion >Options** in the main menu

The cosmos option motion dialog box appears; change the duration to 10 seconds, and number of frame to 500

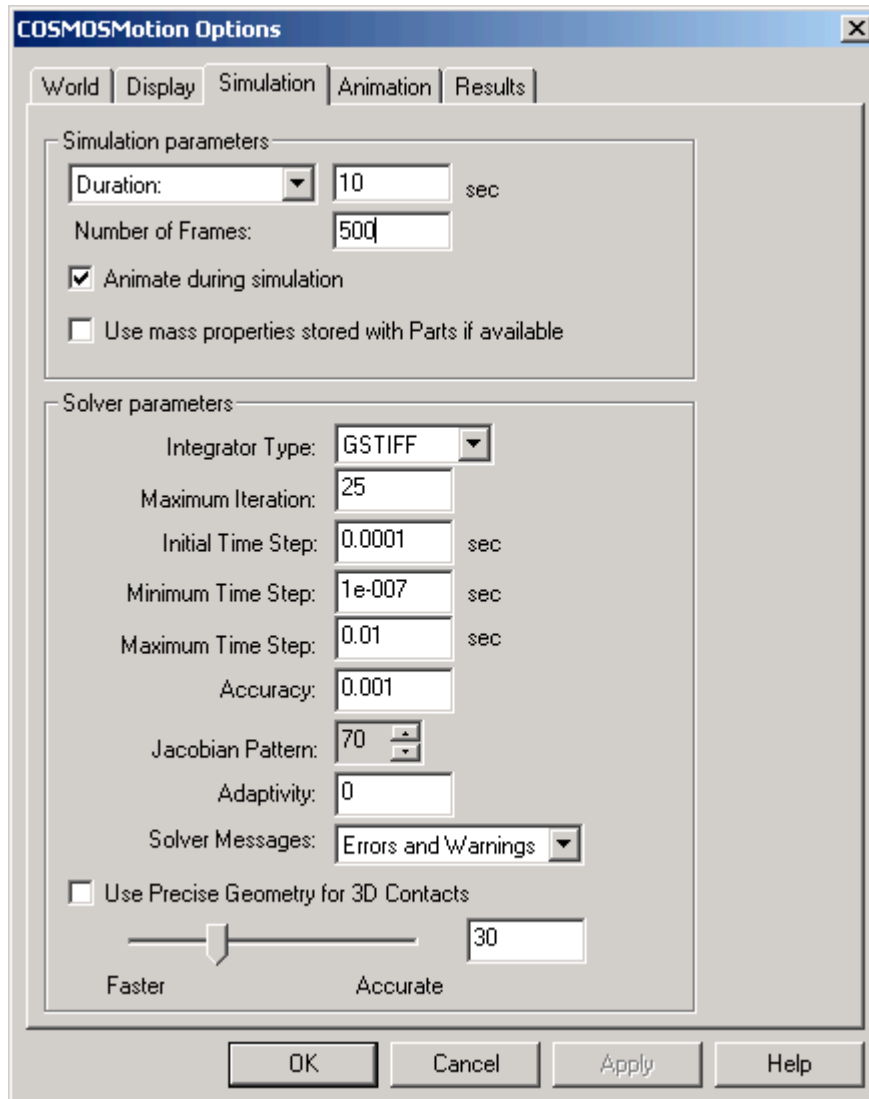

Click on the simulation button (On the bottom of the manager tree), the mechanism works. Right Click on the velocity branch in the Manager tree and select create velocity

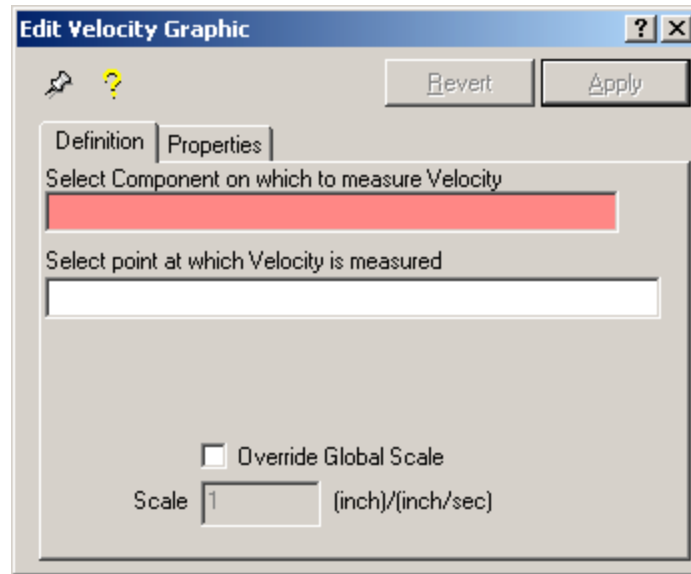

Select the part 1, and click apply

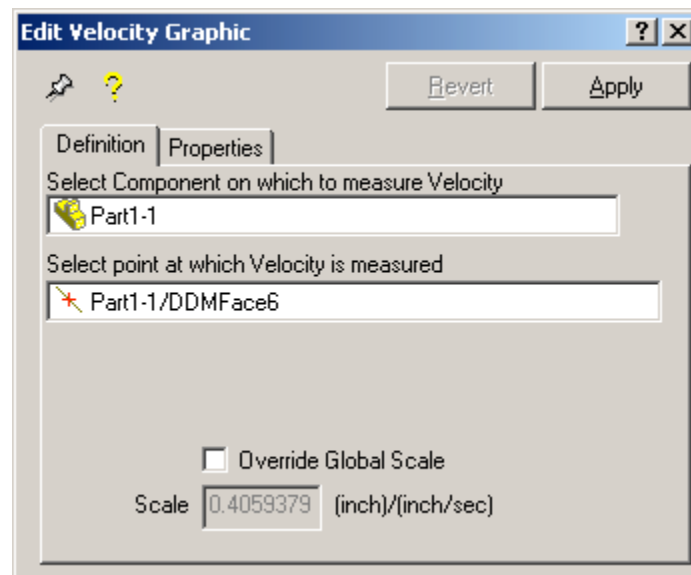

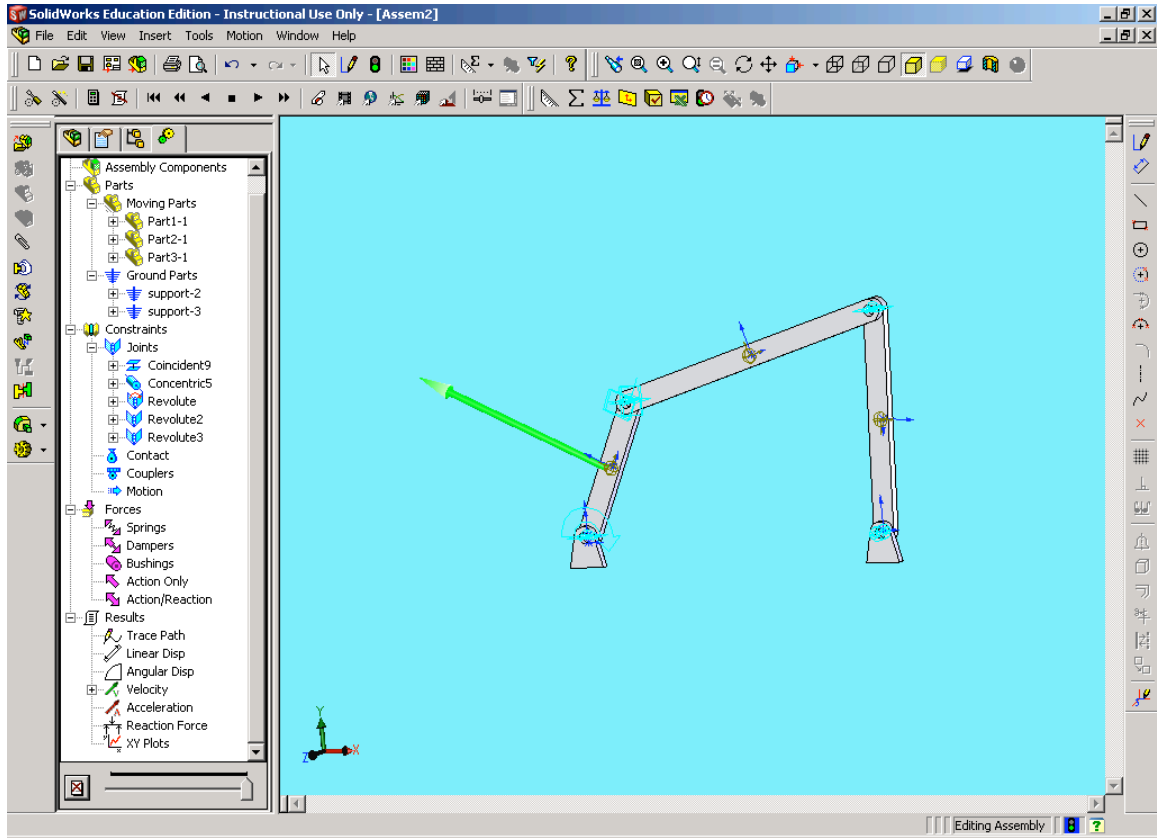

Hide the velocity vector, **Velocity**<**Velocity Graphics**< (right click) **Properties**
Select **hidden** and apply

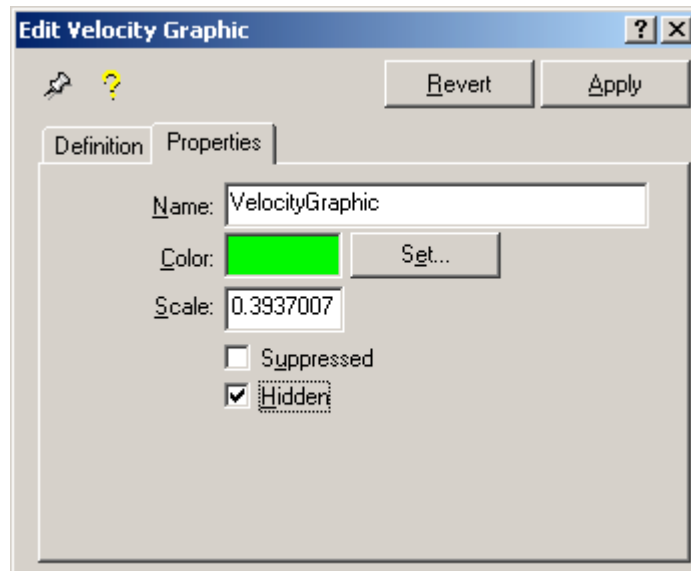

Click twice on the simulation button, Click **Velocity**<**Velocity Graphics**< (right click) plot <**Magnitude**, select **X component** and **Y component**

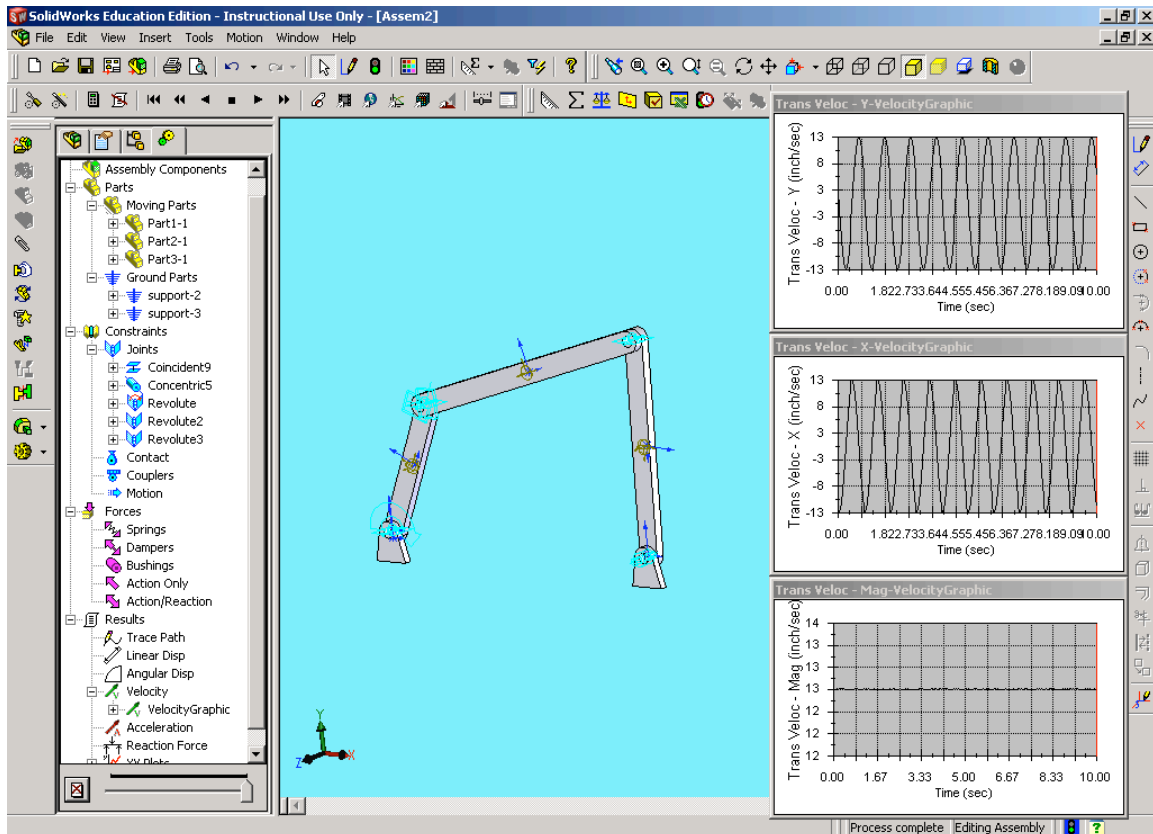

The graphics for the different components of the speed appear

Now, change the angular velocity for an angular acceleration, and repeat the procedure

- What is the maximum velocity in the Y direction?
- In what period of time is the max velocity repeated? (Periodic time)
- What is the maximum Velocity (Magnitude) in the Part 1?

- Repeat the exercise with an angular acceleration of 4 rad/sec^2
- What do you observe in the plot acceleration (magnitude) vs Time?
- Export the result to excel **Motion>Export>Excel (Spreadsheet)**