



**STEVENS**  
INSTITUTE *of* TECHNOLOGY  
THE INNOVATION UNIVERSITY

# Homework 5

March 8, 2013

CPE-322, Engineering Design VI

*A collaborative effort on behalf of*

Takahiro Akiyama  
Paul Di Santi  
Robert Stephenson  
Stanley Switalski

I pledge my Honor that I have abided by the Stevens Honor System.

Takahiro Akiyama      x \_\_\_\_\_

Paul Di Santi            x \_\_\_\_\_

Robert Stephenson    x \_\_\_\_\_

Stanley Switalski        x \_\_\_\_\_

## *Section 1*

<b>Team Member</b>	Takahiro Akiyama	Paul Di Santi	Robert Stephenson	Stanley Switalski
<b>Percentage of Effort Towards Assignment</b>	25%	25%	25%	25%

## *Section 2*













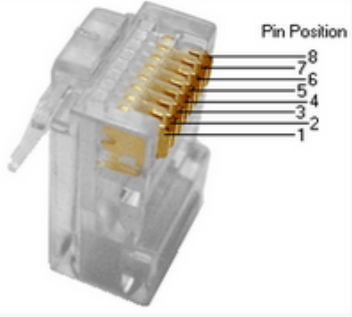



At one point in a network engineer's career, organization is lost and plans that dictate where cables are running are lost as well. This becomes a problem when there are network communication issues or when troubleshooting a network problem. The first step can be to verify the physical network connection and if the end device is right next to its next hop, you can simply check that the cable is in working condition, verify that the cable is connected into the correct ports, and that the link light are on at either device. On occasion, the two are not in close enough proximity for this to be possible. Additionally, devices can be located anywhere within a data center which can spread over hundreds or thousands of feet coupled with hundreds or even thousands of devices and connections, making the task of tracing cables very daunting as well as time consuming. Rather than having to use laptops or trace wires, one could select a room, plug a device into the wall drops, and have the corresponding port illuminate in the IDF/MDF. Link lights could then be installed on each device so that one can easily determine if there is a basic network connection active. This would make it possible to go to any connection point and see a link light. This would be accomplished by having LEDs embedded with the connectors at either end of every cable.

In our project, a key device is the Ethernet insert device. From a connectional point of view, this device is responsible for both illuminating the Ethernet cable as well as illuminating the LED on the patch panel. In order to illuminate anything, power will have to be transferred over the Ethernet cable. Fortunately for our team, IEEE has defined a standard they call 802.3af. This is commonly called Power over Ethernet, or POE for short. The following paragraphs outline 802.3, POE and how we can use it to implement our design.

The 802.3 was the original Ethernet standard established by the IEEE in 1983 encompassing all Ethernet based communications. Over time, the IEEE has expanded 802.3 to include many sub-standards including 802.3i, 802.3y, and 802.3ab which outline Ethernet communications over what is now the standard UTP Ethernet cable. For the purposes of this project, the focus will be on 802.3ab coupled with 802.3af since the proposed design will be a modified CAT6 Ethernet cable with a POE connection.

## Homework 5 Design Project

802.3ab uses consists of eight wires with four groups of twisted pairs. Each end of the cable is terminated with a standard RJ45 Ethernet connector which is regularly used for networking and other forms of communications. The following pin out diagram outlines the two standardized pin outs for an RJ45 connector:

Pin	T568A Pair	T568B Pair	1000BASE-T Signal ID	Wire	T568A Color	T568B Color	Pins on plug face (socket is reversed)
1	3	2	DA+	tip	 white/green stripe	 white/orange stripe	
2	3	2	DA-	ring	 green solid	 orange solid	
3	2	3	DB+	tip	 white/orange stripe	 white/green stripe	
4	1	1	DC+	ring	 blue solid	 blue solid	
5	1	1	DC-	tip	 white/blue stripe	 white/blue stripe	
6	2	3	DB-	ring	 orange solid	 green solid	
7	4	4	DD+	tip	 white/brown stripe	 white/brown stripe	
8	4	4	DD-	ring	 brown solid	 brown solid	

Typically, only two pairs are used for data communications. The other two pairs are open/not used in 802.3ab implementations. A unique element of UTP (unshielded twisted pair) cables is that they, in fact, have twisted pairs. The pairs are twisted together in order to cancel out any EMI (electromagnetic interference) caused by outside elements as well as “cross-talk” from neighboring pairs. The concept was originally introduced by Alexander Graham Bell and has proven effective in preventing EMI. For the purposes of this project, the twisted pairs will be crucial in preventing any EMI caused by the additional features we add to our customized cables.

In order to save money and time when installing networks, POE was drafted to enable the use of one cable for data and power. This streamlines the installation of equipment in hard to reach areas or areas without easy power access. To complete the installation, two main pieces of equipment are required. The first is the cable and the second is the power supply. To ensure compatibility with pre-existing network devices, Cat 5/5E/6 cabling was selected for the 802.3af standard. The power supply in the standards documentation has been called Power Sourcing Equipment, or PSE for short.

When plugging a device into a PSE enabled network, not all the connected devices will need power. As such, 802.3af outlines a detection and classification process to ensure that the added power will not damage legacy or incompatible equipment. Based on resistance and capacitance, only devices which complete this “Resistive Power Discovery” process will be provided power. Once the device and PSE have agreed that the device can be powered by PSE, there is a second order of negotiation that needs to occur. This is to determine how the power will be provided.

## Homework 5 Design Project

802.3af outlines two different ways to provide power. The first is phantom power. With phantom power, power is provided over the same pins data is transferred on. In a standard network, this means power and data is transferred over pins one, two, three and six. On the device end, a DC/DC converter is coupled to the respective pins in order to draw power from the mixed signal.

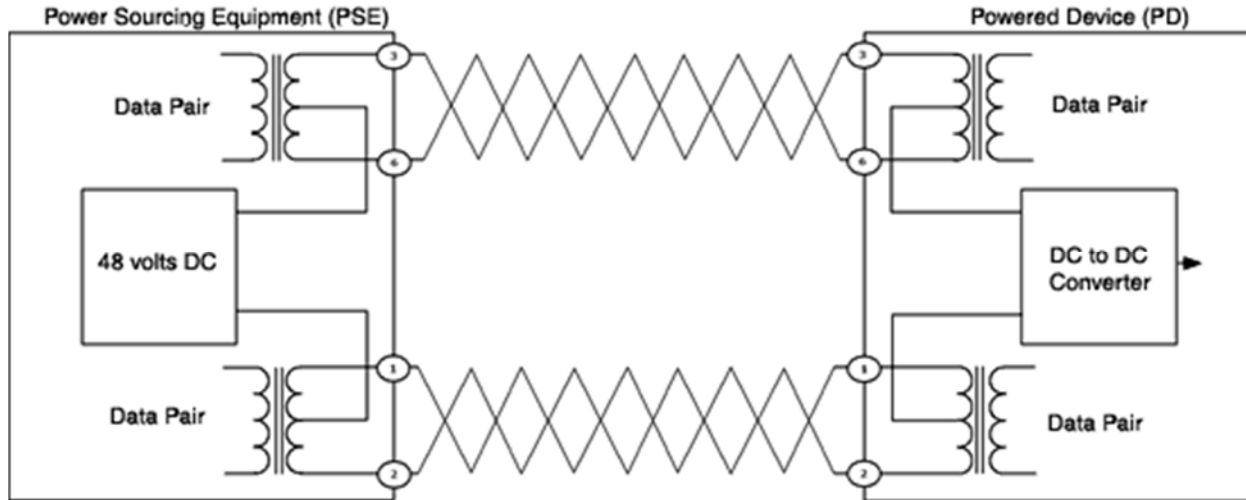

Source: [http://www.bb-elec.com/Learning-Center/All-White-Papers/Ethernet/Power-over-Ethernet-\(PoE\).aspx](http://www.bb-elec.com/Learning-Center/All-White-Papers/Ethernet/Power-over-Ethernet-(PoE).aspx)

The second is spare-pair power. By nature of Cat 5/5e/6 networking, four of the eight pins are not used for transferring data. In this scheme, pins four, five, seven and eight are used to transmit power. Unfortunately, while phantom power works in both four and eight pin networks, spare-pair power requires all eight pins in order to function.

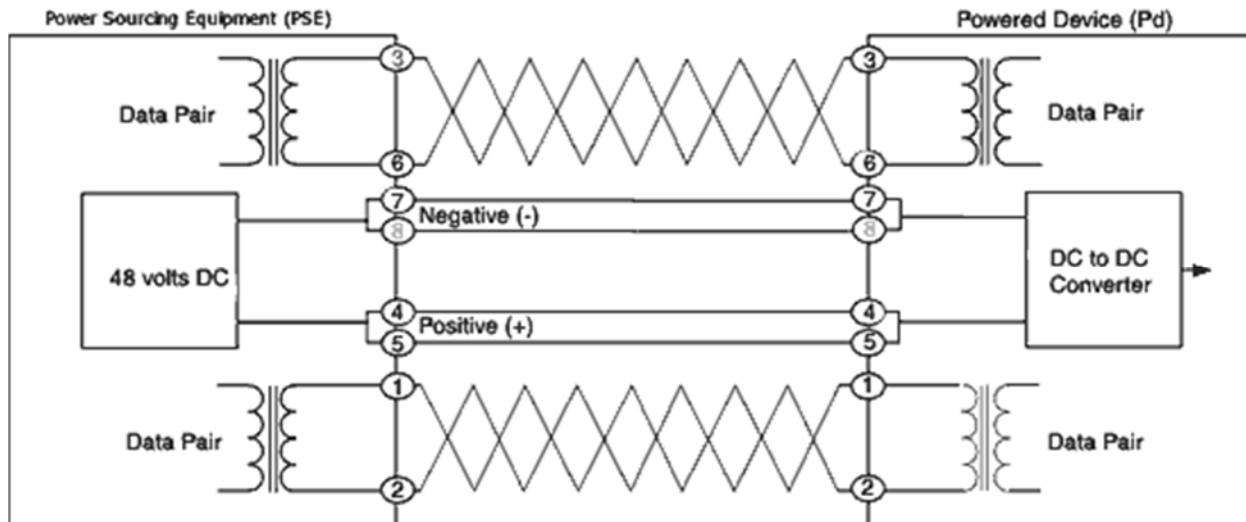

## Homework 5 Design Project

---

Source: [http://www.bb-elec.com/Learning-Center/All-White-Papers/Ethernet/Power-over-Ethernet-\(PoE\).aspx](http://www.bb-elec.com/Learning-Center/All-White-Papers/Ethernet/Power-over-Ethernet-(PoE).aspx)

Once the device has established power, it can fit into one of four 802.3af power classes. These classifications are provided below.

Class	Purpose	Minimum Level at the exit of PSE
0	Default	15.4 watt
1	Optional	4.0 watt
2	Optional	7.0 watt
3	Optional	15.4 watt
4	Reserved for future applications	Handle as class 0

Source: [http://www.belden.com/docs/upload/poe\\_basics\\_wp.pdf](http://www.belden.com/docs/upload/poe_basics_wp.pdf)

Another important factor in determining the effective power is the length of the cable. Considering the maximum power output of 15.4 watts, with 350mA at a minimum voltage of 44 volts, “a standard Cat5 cable with a length of 100m attains a resistance of approximately 20Ω. The power loss results in approximately 2.45 watts” (Belden.com). Since our application is concerned with the 3-12 volt range, we should be perfectly fine even with power losses.

When building the device that activates the EL wire and LED devices, we will also need to ensure that we apply proper Ethernet isolation techniques. According to the 802.3af standard, “1500 VRMS isolation is needed between the 48 V supply (and anything attached to it)” (White).

EL Wire (electroluminescent wire) is a wire that glows when an alternating current is applied to it. The key component in producing this glow is an electroluminescent phosphor which emits light when any voltage is applied through it.

EL wire is constructed of five major components. The two outer most components are protective sleeves. The inner most being clear and the outer most being colored PVC, this can be a large variety of colors and could also be clear as well. The inner three components are where the glowing effect occurs. There is a solid-copper wire core coated in the electroluminescent phosphor. The phosphor can be made from a range of materials, including zinc sulfide doped with copper or manganese, blue diamond with traces or boron as a dopant, or semiconductors containing group three and five elements such as indium phosphide, gallium arsenide, and gallium nitride.

## Homework 5 Design Project

---

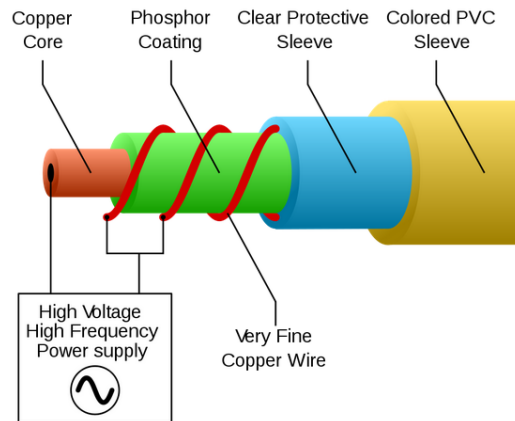

Now to make the EL wire glow, an AC voltage needs to be applied to the inner and outer copper wires. This voltage is typically between 90V to 200VRMS at a frequency in the low kilohertz. The brightness of the EL wire depends highly on the power applied, however it would be possible to power EL wire directly with the standard 120VAC, 60Hz line power.

For something more portable a DC to high frequency AC converter can be used. This DC source would normally be from 6V to 12V which can be sourced from common batteries. When applying the power it is important to know that the power is not applied at the two ends of the wire however between the inner and outer wire, thus through the electroluminescent phosphor coating.

EL wire is relatively thin and will not increase the diameter of the Ethernet cable immensely. Ethernet cable has an average diameter of six to seven millimeters. EL wire comes in a variety of diameters, but we would be utilizing its thin diameter of 1.3 millimeters. This would at most increase the diameter of the Ethernet cable to 8.6 millimeters.

Our goal in this project would be to implement both the Ethernet insert device as well as the EL wire. With the implementation of the two, it would make it possible for anyone to locate exactly where a cable is running and to differentiate which cable is the cause of failure.

## *Section 3*

### *Part 1*

Some restraints that we will face during design include adhering to economic, environmental, health and safety, manufacturability and sustainability restraints. Economically our product needs to compete with products that may have less functionality but have been in use for years and have known reliability. The added cost of our products additional features must be minimalized to create the most enticement to change to our product. Our product is constrained by the environment that it is used in again as it must fit where there is existing equipment. This creates a constraint on the size of the product, as the additional features will increase its size. The only Health and Safety's constraints on our product is that it must be as reliable or more reliable than existing products as we cannot know what systems our product will be used in. Manufacturing constraints on the products can be a subset of its economic and sustainable qualities. The product must have ease of manufacturing while having a lost cost as to keep the overall cost down while not negativity affecting its sustainability.

### *Part 2*

The responsibilities associated with our product is to ensure that is made in accordance with the industry standard for the EL wire and patch panels embedded with LEDs. The product must be cost effective as well as reliable to ensure customers will purchase our product over generic wires or patch panels.

## Section 4

Low cost solution	→	Directly Important
Complies with Standards	→	Directly Important
Easy to Install	→	Appeals to IT Managers
Decreases Network Downtime	→	Appeals to everyone
Easy to use	→	Appeals to IT Staff
Single Activation Component	→	Appeals to IT Staff
Isolates Network Issues	→	Appeals to IT Managers
Fits within existing environment	→	Promotes sales
Uses light as an indicator	→	Promotes sales
Uses cheap, easily available materials	→	Appeals to Fabrication



# Homework 5 Design Project

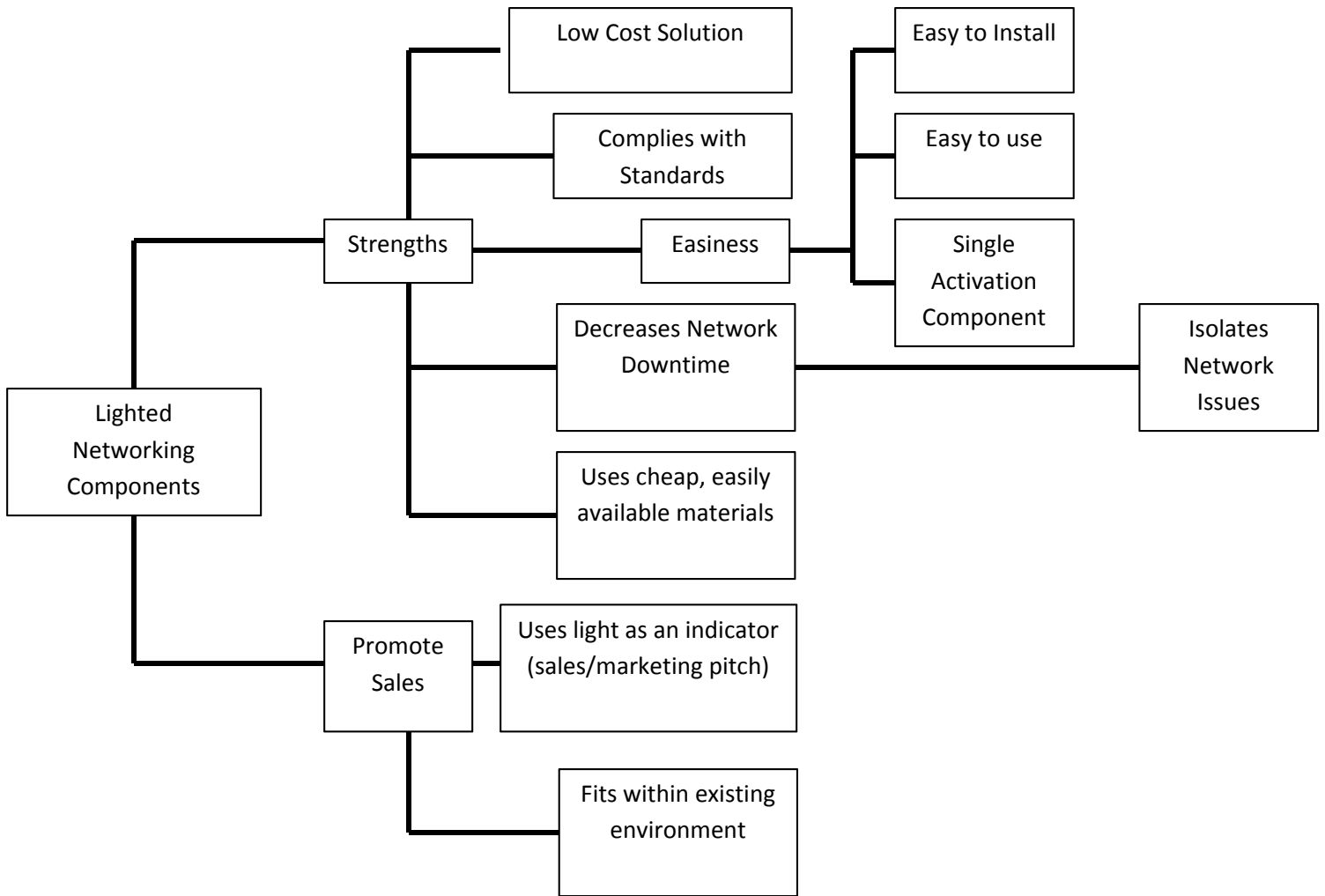

## *References*

- Cisco Systems. "Connector Pin Assignments." *Cisco Content Delivery Engine*. N.p., n.d. Web. 24 Feb. 2013. <[http://www.cisco.com/en/US/docs/video/cds/cde/cde205\\_220\\_420/installation/guide/Connectors.html](http://www.cisco.com/en/US/docs/video/cds/cde/cde205_220_420/installation/guide/Connectors.html)>.
- IEEE-SA Standards Board. "IEEE 802.3: ETHERNET." *Standards.ieee*. N.p., n.d. Web. 17 Feb. 2013. <<http://standards.ieee.org/about/get/802/802.3.html>>.
- White, R.V.; , "Electrical isolation requirements in power-over-Ethernet (PoE) power sourcing equipment (PSE)," *Applied Power Electronics Conference and Exposition, 2006. APEC '06. Twenty-First Annual IEEE* , vol., no., pp. 4 pp., 19-23 March 2006  
URL: <http://ieeexplore.ieee.org/stamp/stamp.jsp?tp=&arnumber=1620633&isnumber=33947>
- Unterdorfer, Pascal. "Power over Ethernet." Hirschmann Automation and Control GmbH, 30 June 2008. Web. 18 Feb. 2013. <[http://www.belden.com/docs/upload/poe\\_basics\\_wp.pdf](http://www.belden.com/docs/upload/poe_basics_wp.pdf)>.
- Burgess, Joanna. "How Electroluminescent (EL) Wire Works" 02 August 2010. HowStuffWorks.com. <<http://science.howstuffworks.com/electroluminescent-wire.htm>> 18 February 2013.
- "Electroluminescent Wire." *El Wire*. N.p., n.d. Web. 20 Feb. 2013. <<http://www.elwire.net/>>.