

Final Exam

E246 Electronics and Instrumentation (Fall 2005)





Name: Solutions

SID: _____

Choose 3 (and only 3) out of 4 problems to solve. Each chosen problem carries equal weight. 100 points total. Do all work in the spaces provided. Show all work and organize it for partial credit. Include units in your answer. Open book, open notes.

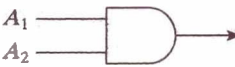
Problem 1. Use the switching devices listed in the Table, draw the logic circuit for the following equation. Simplify the equation, and construct a truth table for the simplified equation.

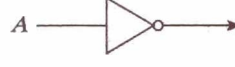
$$X = \overline{A \cdot \overline{B} + A \cdot (\overline{A} + C)}$$

TABLE 13.5 Switching Devices			
Operator	Symbol	Input/output relationship	
AND		$f(A_1, A_2)$	$f(A_1, A_2) = A_1 A_2$
OR		$f(A_1, A_2)$	$f(A_1, A_2) = A_1 + A_2$
NOT		$f(A)$	$f(A) = \overline{A}$
NAND		$f(A_1, A_2)$	$f(A_1, A_2) = \overline{A_1 A_2}$
NOR		$f(A_1, A_2)$	$f(A_1, A_2) = \overline{A_1 + A_2}$

Solution:

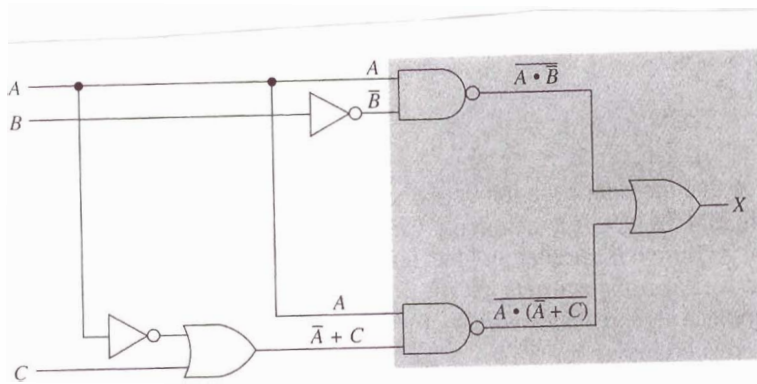

Next, we use De Morgan's theorem and Boolean algebra to simplify the equation:

$$\begin{aligned} X &= \overline{A \cdot \overline{B}} + \overline{A \cdot (\overline{A} + C)} \\ &= (\overline{A} + \overline{\overline{B}}) + (\overline{A} + \overline{\overline{A} + C}) \\ &= \overline{A} + B + \overline{A} + \overline{\overline{A} \cdot C} \\ &= \overline{A} + \overline{A} + A\overline{C} + B \\ &= \overline{A} + A\overline{C} + B \end{aligned}$$

Apply Rule $(A + \overline{A}B = A + B)$,

$$X = \overline{A} + \overline{C} + B \quad \leftarrow \text{simplified equation}$$

Truth table:

A	B	C	$X = \overline{A} + \overline{C} + B$
0	0	0	1
0	0	1	1
0	1	0	1
0	1	1	1
1	0	0	1
1	0	1	0
1	1	0	1
1	1	1	1

Problem 2. Simplify the following equation using the Karnaugh mapping procedure:

$$X = \overline{A}\overline{B}\overline{C} + \overline{A}\overline{C}\overline{D} + \overline{A}\overline{B} + \overline{A}BC\overline{D} + \overline{A}\overline{B}C$$

Solution:

$$X = \overline{A}\overline{B}\overline{C}(D+\overline{D}) + \overline{A}(B+\overline{B})\overline{C}\overline{D} + \overline{A}\overline{B}(C+\overline{C})(D+\overline{D}) + \overline{A}BC\overline{D} + \overline{A}\overline{B}C(D+\overline{D})$$

$$= \overline{A}\overline{B}\overline{C}\overline{D} + \overline{A}\overline{B}\overline{C}D + \overline{A}B\overline{C}\overline{D} + \overline{A}\overline{B}\overline{C}\overline{D} + \overline{A}BCD + \overline{A}\overline{B}C\overline{D} + \overline{A}\overline{B}\overline{C}D + \overline{A}\overline{B}\overline{C}\overline{D} + \overline{A}BC\overline{D} + \overline{A}\overline{B}C(D+\overline{D})$$

$$= \overline{A}\overline{B}\overline{C}\overline{D} + \overline{A}\overline{B}\overline{C}D + \overline{A}B\overline{C}\overline{D} + \overline{A}\overline{B}\overline{C}\overline{D} + \overline{A}BCD + \overline{A}\overline{B}C\overline{D} + \overline{A}\overline{B}\overline{C}D + \overline{A}BC\overline{D} + \overline{A}\overline{B}C\overline{D}$$

$$= \sum m(0, 1, 12, 8, 11, 10, 9, 14, 3, 2)$$

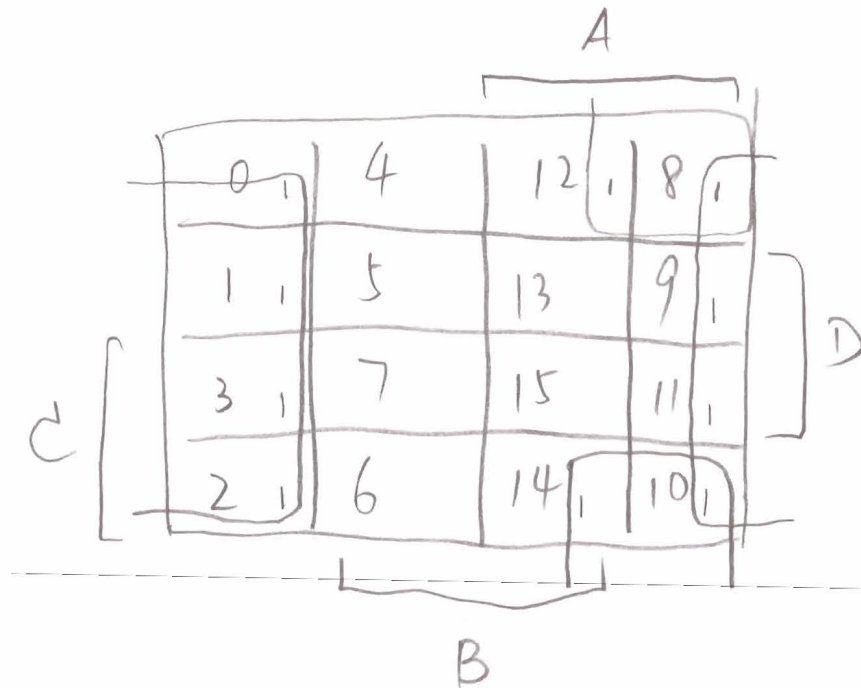

For the 8-cell group, it's simplified as \overline{B} ,

For the 4-cell group, it's simplified as $A\overline{D}$.

So $X = \overline{B} + A\overline{D}$

Problem 3. A chemical plant needs a microprocessor-driven alarm system to warn of critical conditions in one of its chemical tanks. The tank has four HIGH/LOW (1/0) switches that monitor temperature (T), pressure (P), fluid level (L), and weight (W). Design a system that will notify the microprocessor to activate an alarm when any of the following conditions arise:

1. High fluid level with high temperature and high pressure;
2. Low fluid level with high temperature and high weight;
3. Low fluid level with low **temperature** and high pressure;
4. Low fluid level with low weight and high temperature.

Write the Boolean equation. Simplify it if possible. And draw the circuit implementation.

Solution: $Alarm = LTP + \bar{L}TW + \bar{L}\bar{T}P + \bar{L}\bar{W}T$

Simplification: $Alarm = \cancel{f(T, L, T, P, W)}$

$$= LTPW + LTP\bar{W} + \bar{L}TPW + \bar{L}T\bar{P}W + \bar{L}\bar{T}Pw + \bar{L}\bar{T}P\bar{w}$$

$$+ \bar{L}\bar{T}P\bar{w} + \bar{L}T\bar{P}\bar{w}$$

$$= \sum m(2, 3, 4, 5, 6, 7, 14, 15)$$

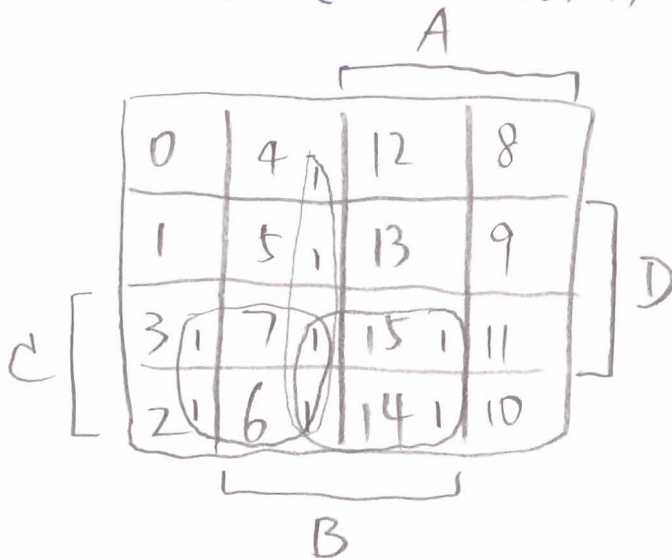

A: L, B: T; C: P; D: W

$$Alarm = \bar{L}T + \bar{L}P + TP$$

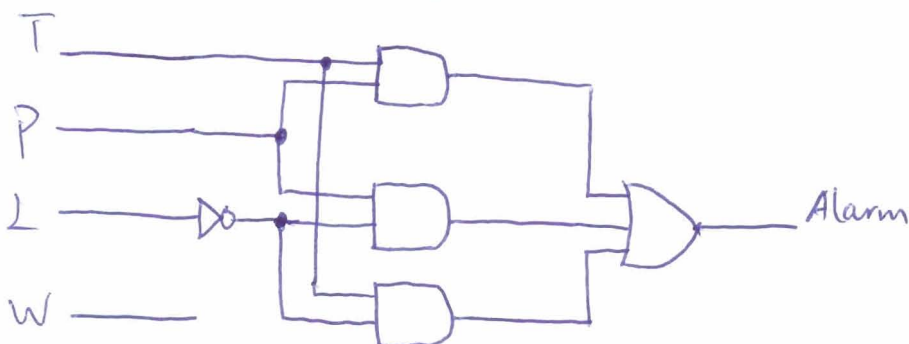

Problem 4. A simple inverter using an n-channel enhancement-mode MOSFET is shown in Figure (a). Use the transistor model shown in Figure (b) to obtain the transfer characteristics of this inverter, a plot of V_0 versus V_i .

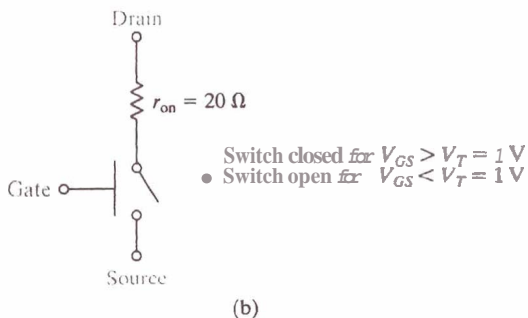
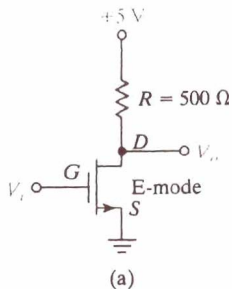

Solution:

