

E246: Electronics & Instrumentation

Introduction to Electronics

Yi Guo
ECE Dept.



Plan

- # Analog and Digital Systems
 - # Modulation and Demodulation
 - # A/D and D/A Converters
 - # Logic Gates
 - # Sensors
 - # Section in textbook: 8.1-8.7
-

Introduction

- # The field of *electronics* involves the use of devices and circuits that specifically control the flow of electric current to achieve some purpose

Analog and Digital Signals

- # Analog signals vary continuously with time
- # Digital signals switch between discrete levels

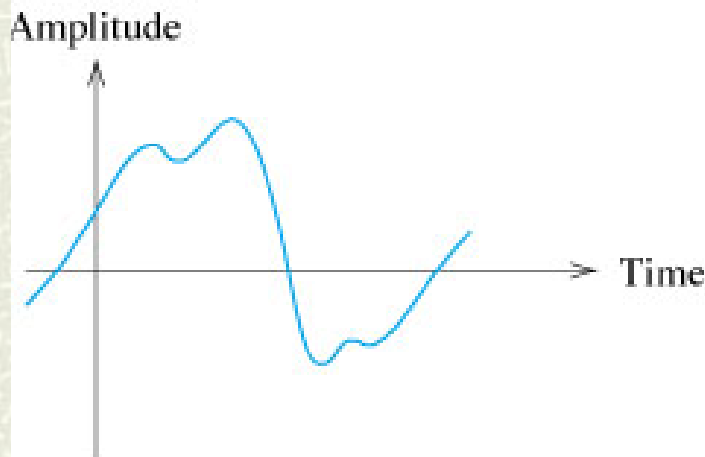

(a) Analog signal

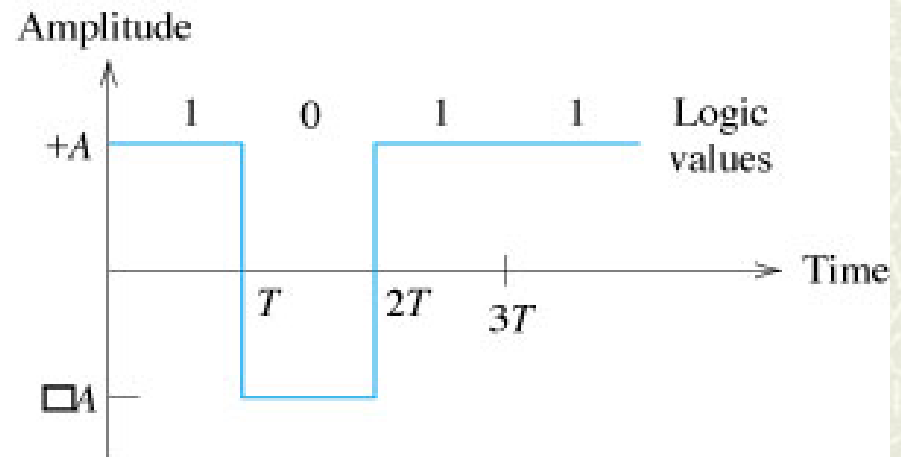

(b) Digital signal

Analog Systems: Amplifiers

- # An amplifier is an electronic circuit that is used to increase the amplitude of a signal

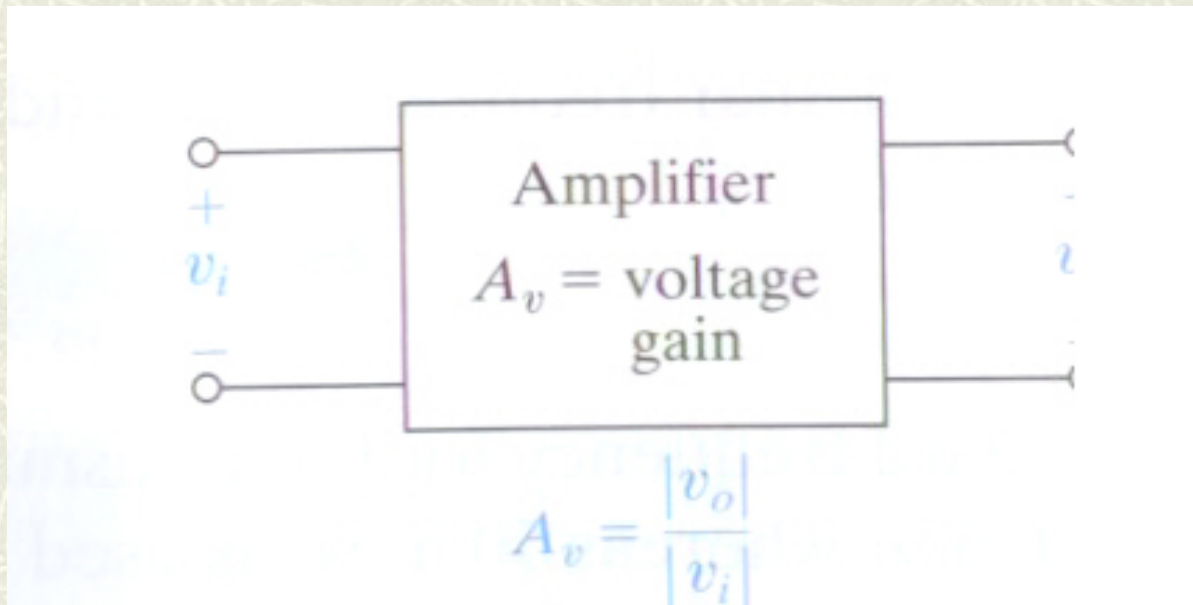

Modulation

- # Modulation is the process to encode information on an analog signal
 - # Demodulation is the reverse process in which the information is extracted from an analog signal
 - # Three types of modulation according to the desired information represented: Amplitude modulation, frequency modulation, and phase modulation
-

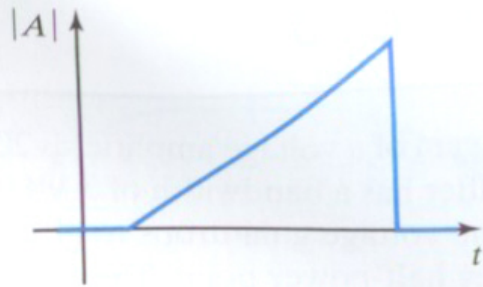

(a) Baseband signal

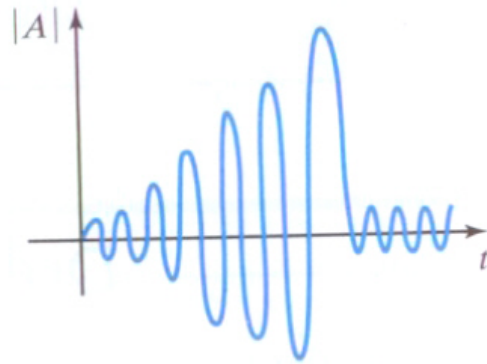

(b) AM modulated signal

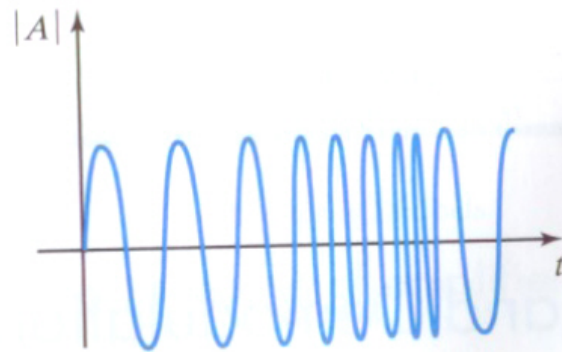

(c) FM modulated signal

Digital Systems

- # Digital systems utilize circuits with binary logic
 - # Data is represented by a voltage switching between a low level (logic 0) and a high level (logic 1)
 - # The single unit of digital information is called “bit”
-

Representing Information in Bits

Range	Bit status	
	MSB	LSB
$0.0 < v < 0.5$	0	0
$0.5 < v < 1.0$	0	1
$1.0 < v < 1.5$	1	0
$1.5 < v < 2.0$	1	1

- Resolution Z is related to the number of bits, n , by $Z=2^n$
-

A/D and D/A Converters

- # Analog to digital converters convert an analog voltage into a digital or binary representation of the voltage
 - # Digital to analog converters convert a digital signal to an analog voltage level
-

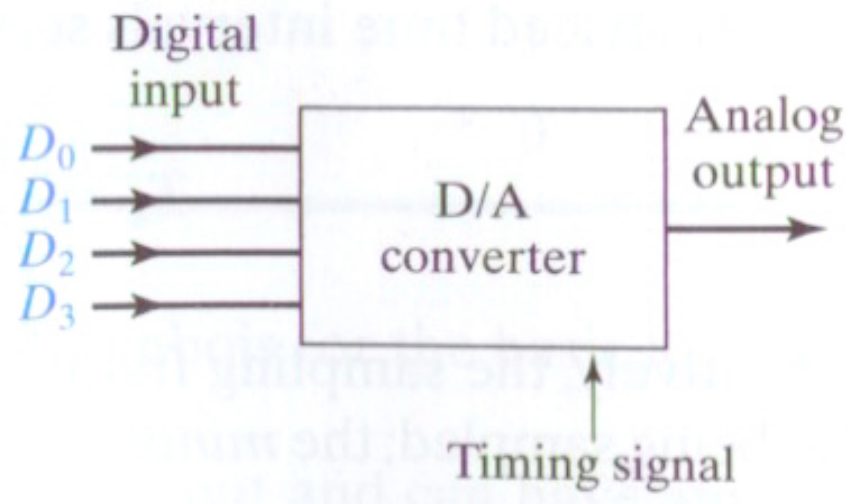
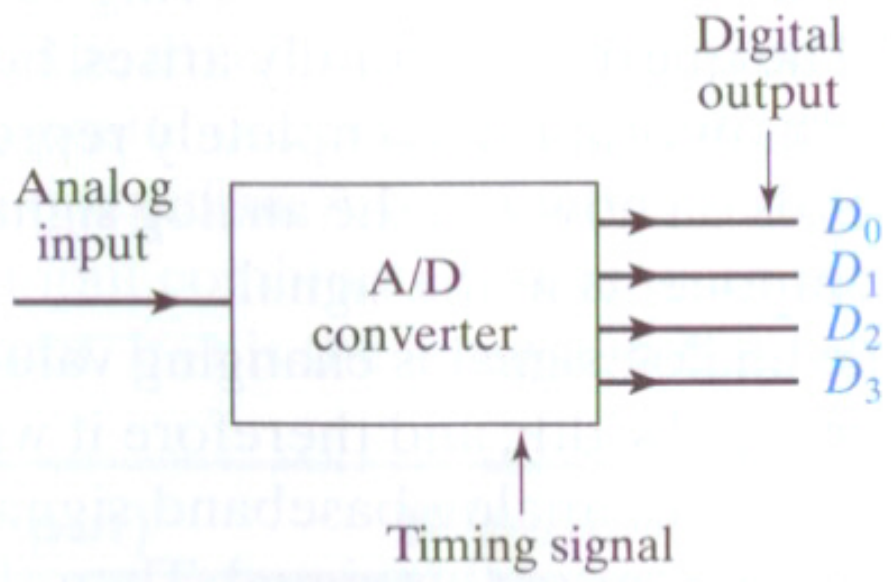

Digital-to-Analog (D/A) Converter

3-Bit Digital-to-Analog Conversion

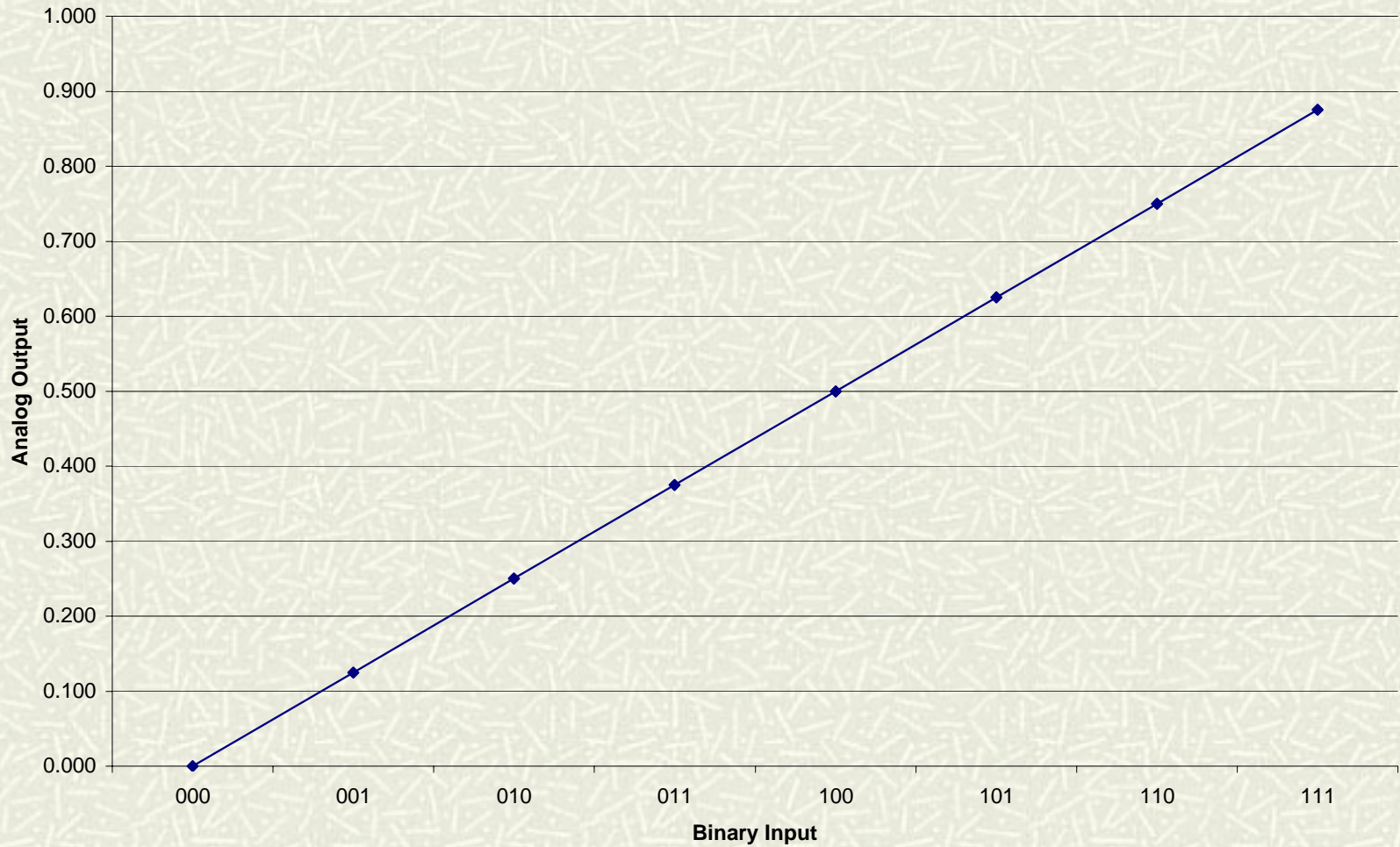

D/A and A/D Converter

3-Bit Digital-to-Analog Conversion

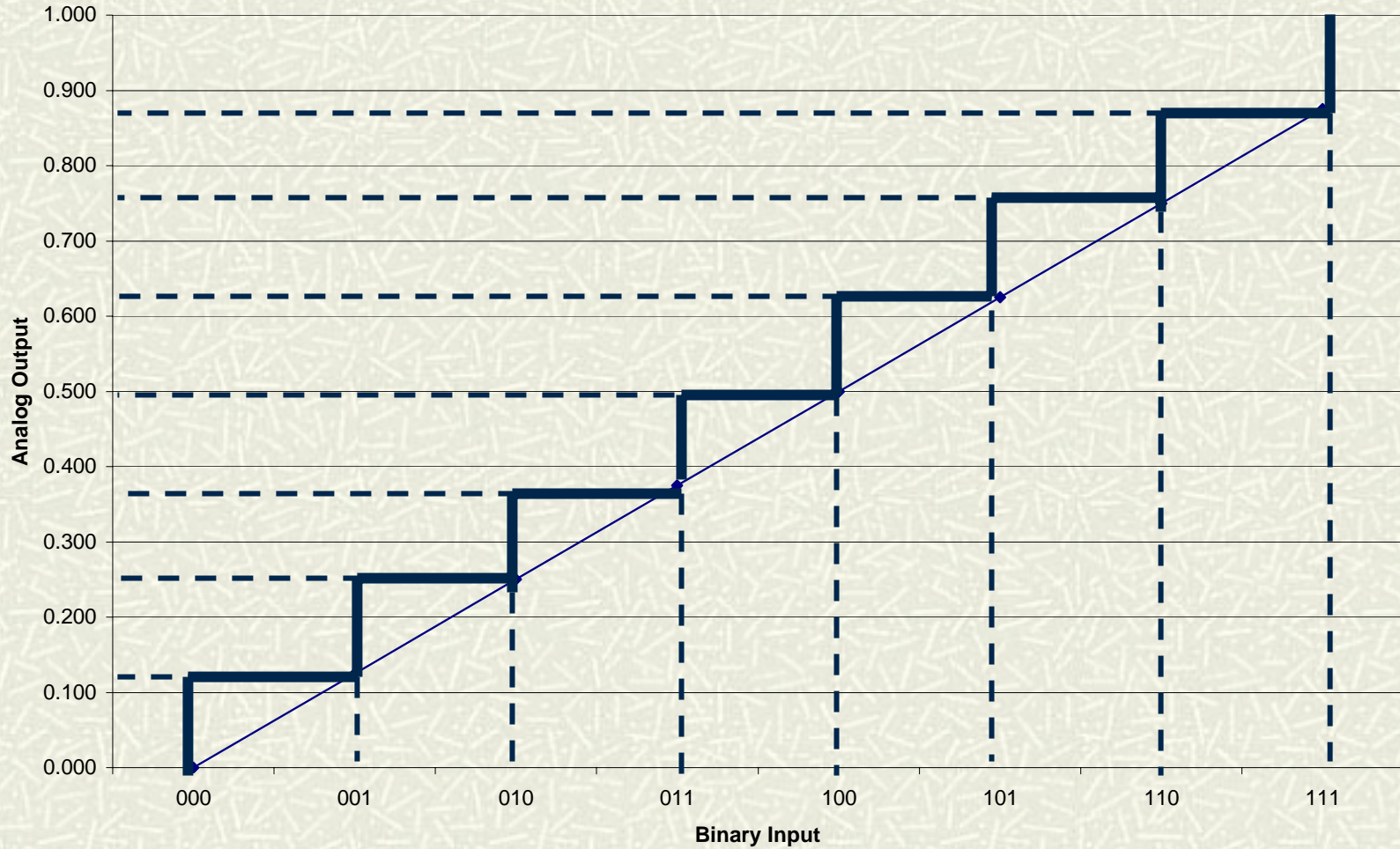

Logic Gates

- # Information represented as 1s and 0s in a digital system is processed by elements called logic gates
 - # The logic state of the output of the gate is uniquely determined by the logic values of the inputs, for example, the output of a AND-gate is 1 if all inputs are 1s, the output of a OR-gate is 1 if any input is 1
-

Sensors

- # Sensors (also called transducers) are devices that sense physical quantities and generate corresponding electronic signals
 - # Actuators are devices that transform electrical signals to a physical action
-

Compass Sensor

- # Analog compass can distinguish eight directions, which are represented by different voltage levels
 - # Digital compass are more complex, and provide a much higher directional resolution (1 degree, and accuracy of 2 degrees)
-

Vector 2X Compass

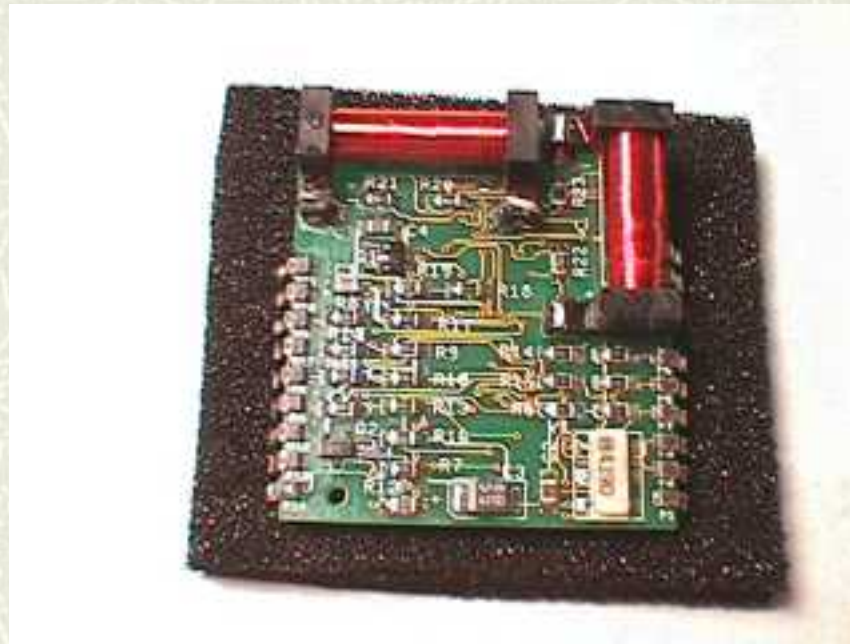
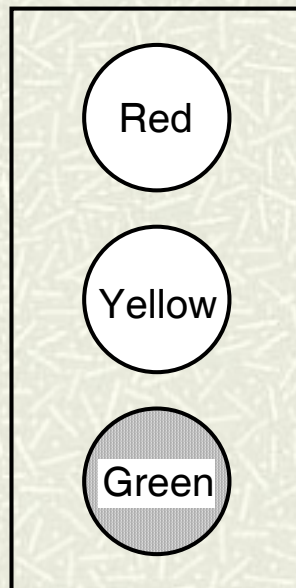
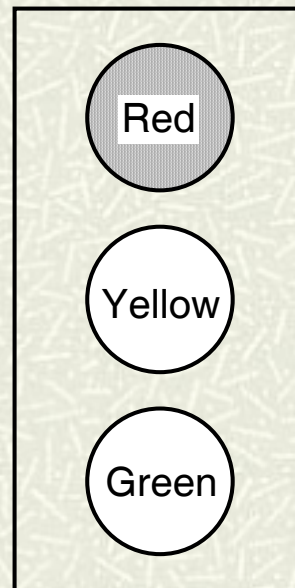

Table 7.5 Traffic Light States

State	North - South	East - West	Delay (sec.)
1	Green	Red	2
2	Yellow	Red	1
3	Red	Red	1
4	Red	Green	2
5	Red	Yellow	1
6	Red	Red	1



North - South



East - West